



# Flygt 3202, 50Hz



# Table of Contents

<b>F-pump, Standard Motor</b> .....	<b>2</b>
Product description.....	2
Motor rating and performance curves.....	4
<b>F-pump, Premium Efficiency Motor (IE3)</b> .....	<b>8</b>
Product description.....	8
Motor rating and performance curves.....	10
<b>N-pump, Standard Motor</b> .....	<b>14</b>
Product description.....	14
Motor rating and performance curves 3202.180/.090/.185/.095.....	17
Motor rating and performance curves 3202.660/.670.....	21
<b>N-pump, Premium Efficiency Motor (IE3)</b> .....	<b>23</b>
Product description.....	23
Motor rating and performance curves 3202.800/.810.....	26
Motor rating and performance curves 3202.820/.830.....	29
Motor rating and performance curves 3202.860/.870.....	33
<b>Dimensions and Weight, Standard Motor</b> .....	<b>36</b>
Drawings.....	36
<b>Dimensions and Weight, Premium Efficiency Motor (IE3)</b> .....	<b>46</b>
Drawings.....	46

# F-pump, Standard Motor

## Product description



### Usage

A submersible chopper pump for heavily contaminated sewage and sludge. The N-hydraulic is fitted with a cutting insert ring. Both impeller and insert ring are manufactured in Hard-Iron™.

### Denomination

Type	Non-explosion proof version	Explosion proof version	Pressure class	Installation types
Hard-Iron™ Chopper	3202.350	3202.390	MT – Medium head HT – High head SH – Super head	P, S, T, Z

The pump can be used in the following installations:

- P Semi permanent, wet well arrangement with pump installed on two guide bars with automatic connection to discharge.
- S Portable semi permanent, wet well arrangement with hose coupling or flange for connection to discharge pipeline.
- T Vertical permanent, dry well arrangement with flange connection to suction and discharge piping.
- Z Horizontal permanent, dry well arrangement with flange connection to suction and discharge piping.

### Application limits

Feature	Description
Liquid temperature	Maximum 40°C (104°F)
Liquid temperature, warm water version	Maximum 70°C (158°F)
Depth of immersion	Maximum 20 m (65 ft)
pH of the pumped liquid	5.5 - 14
Liquid density	Maximum 1100 kg/m <sup>3</sup>

Motor data

Feature	Description
Motor type	Squirrel-cage induction motor
Frequency	50 Hz
Power supply	3-phase
Starting method	<ul style="list-style-type: none"> <li>• Direct on-line</li> <li>• Star-delta</li> <li>• Variable Frequency Drive (VFD)</li> </ul>
Number of starts per hour	Maximum 30
Code compliance	IEC 60034-1
Voltage variation	<ul style="list-style-type: none"> <li>• Continuously running: Maximum <math>\pm 5\%</math></li> <li>• Intermittent running: Maximum <math>\pm 10\%</math></li> </ul>
Voltage imbalance between phases	Maximum 2%
Stator insulation class	H (180°C, 356°F)

Cables

Application	Type
Direct-on-line start or Y/D start with two cables	Flygt SUBCAB® - a heavy duty 4 cores motor power cable with two twisted pair screened control cores. Conductor insulation rating of 90°C, which allows for increased current. Superior mechanical strength and high abrasion and tear resistant. Chemical resistant within pH 3-10 and ozone, oil, and flame resistant. Used up to 70°C water temperature. Cables < 10 mm <sup>2</sup> with unscreened control cores.
Y/D start	Flygt SUBCAB® - a heavy duty 7 cores motor power cable with two twisted pair screened control cores. Conductor insulation rating of 90°C, which allows for increased current. Superior mechanical strength and high abrasion and tear resistant. Chemical resistant within pH 3-10 and ozone, oil, and flame resistant. Used up to 70°C water temperature. Cables < 7G6 mm <sup>2</sup> with unscreened control cores.
Variable Frequency drive	Screened Flygt SUBCAB® - a heavy duty 4 screened cores motor power cable with four twisted pair screened control cores. Conductor insulation rating of 90°C, which allows for increased current. Superior mechanical strength and high abrasion and tear resistant. Chemical resistant within pH 3-10 and ozone, oil, and flame resistant. Used up to 70°C water temperature.

Monitoring equipment

- Thermal contacts opening temperature 140° C (284° F)
- Leakage sensor in the inspection chamber (FLS 10)

Materials

Table 1: Major parts except mechanical seals

Denomination	Material	ASTM	EN
Major castings	Cast iron, gray	35B	GJL-250
Pump housing	Cast iron, gray	35B	GJL-250
Impeller	Cast iron, Hard-Iron™	A 532 IIIA	GJN-HB555(XCR23)

Denomination	Material	ASTM	EN
Insert ring	Cast iron, Hard-Iron™	A 532 IIIA	GJN-HB555(XCR23)
Cooling jacket, inner	Aluminum	AA 1050A	AW-1050A
Cooling jacket, outer, alternative 1	Steel	GR65	S235JRG2
Cooling jacket, outer, alternative 2	Stainless steel	AISI 316L	1.4404, 1.4432, ...
Lifting handle	Stainless steel	AISI 316L	1.4404, 1.4432, ...
Shaft	Stainless steel	AISI 431	1.4057+QT800
Screws and nuts	Stainless steel, A4	AISI 316L, 316, 316Ti	1.4401, 1.4404, ...
O-rings, alternative 1	Nitrile rubber (NBR) 70° IRH	-	-
O-rings, alternative 2	Fluorinated rubber (FPM) 70° IRH	-	-
Glycol	Heat transfer fluid based on monopropylene glycol.	-	-

Table 2: Mechanical seals

Alternative	Inner seal	Outer seal
1	Corrosion resistant cemented carbide/ Corrosion resistant cemented carbide	Corrosion resistant cemented carbide/ Corrosion resistant cemented carbide
2	Corrosion resistant cemented carbide/ Corrosion resistant cemented carbide	Silicon carbide/ Silicon carbide

### Surface treatment

Priming	Finish
Painted with a primer, see internal standard M0700.00.0002	Navy gray color NCS 5804-B07G. Two-component high-solid top coating, see internal standard M0700.00.0004 for standard painting and M0700.00.0008 for special painting.

### Options

- Warm liquid version (non-explosion proof versions)
- Sensors: Thermistor, FLS, PT 100, VIS 10
- Pump memory
- Surface treatment (Epoxy)
- Zinc anodes
- Other cables

### Accessories

Discharge connections, adapters, hose connections, and other mechanical accessories. Electrical accessories such as pump controller, control panels, starters, monitoring relays, cables.

## Motor rating and performance curves

These are examples of motor rating and curves. For more information, please contact your local sales and service representative.

Star-delta starting current is 1/3 of Direct on-line starting current.

MT

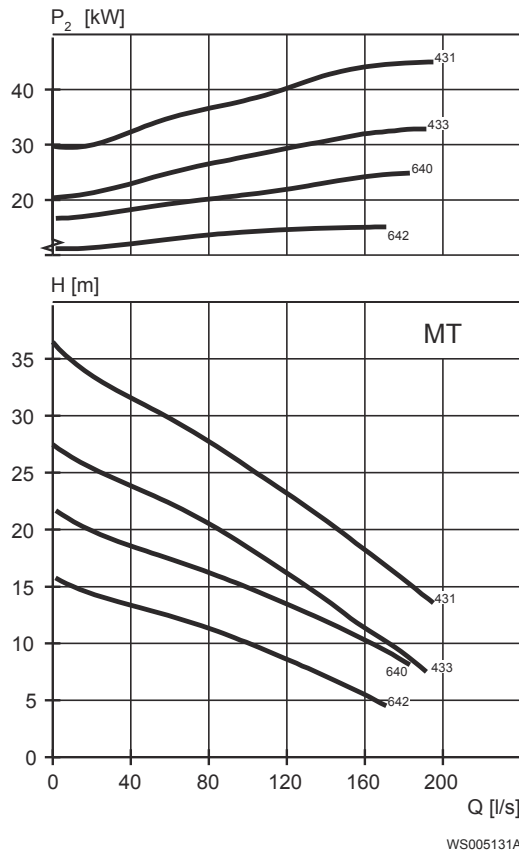

Table 3: 400 V, 50 Hz, 3-phase

Rated power, kW	Rated power, hp	Curve/ Impeller No	Revolutions per minute, rpm	Rated current, A	Starting current, A	Power factor, cos φ	Installation
22	30	641	970	43	238	0.84	P,S,T,Z
22	30	642	970	43	238	0.84	P,S,T,Z
22	30	643	970	43	238	0.84	P,S,T,Z
30	40	434	1475	54	360	0.88	P,S,T,Z
30	40	435	1475	54	360	0.88	P,S,T,Z
30	40	640	970	59	320	0.83	P,S,T,Z
30	40	641	970	59	320	0.83	P,S,T,Z
30	40	642	970	59	320	0.83	P,S,T,Z
30	40	643	970	59	320	0.83	P,S,T,Z
37	50	433	1475	65	420	0.89	P,S,T,Z
37	50	434	1475	65	420	0.89	P,S,T,Z
37	50	435	1475	65	420	0.89	P,S,T,Z
37	50	640	970	71	405	0.83	P,S,T,Z
37	50	641	970	71	405	0.83	P,S,T,Z
37	50	642	970	71	405	0.83	P,S,T,Z
37	50	643	970	71	405	0.83	P,S,T,Z
45	60	431	1475	79	540	0.9	P,S,T,Z
45	60	432	1475	79	540	0.9	P,S,T,Z
45	60	433	1475	79	540	0.9	P,S,T,Z

Rated power, kW	Rated power, hp	Curve/ Impeller No	Revolutions per minute, rpm	Rated current, A	Starting current, A	Power factor, cos φ	Installation
45	60	434	1475	79	540	0.9	P,S,T,Z
45	60	435	1475	79	540	0.9	P,S,T,Z

HT

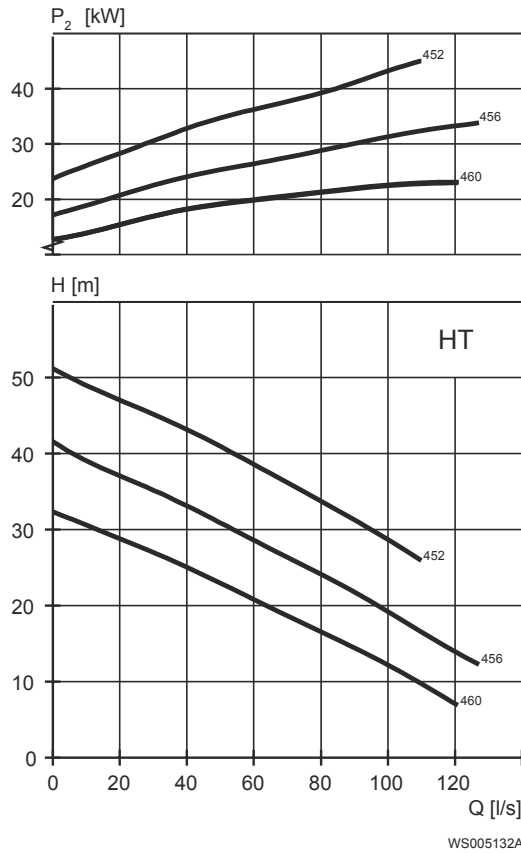

Table 4: 400 V, 50 Hz, 3-phase

Rated power, kW	Rated power, hp	Curve/ Impeller No	Revolutions per minute, rpm	Rated current, A	Starting current, A	Power factor, cos φ	Installation
30	40	456	1475	54	360	0.88	P,S,T,Z
30	40	458	1475	54	360	0.88	P,S,T,Z
30	40	460	1475	54	360	0.88	P,S,T,Z
37	50	456	1475	65	420	0.89	P,S,T,Z
37	50	458	1475	65	420	0.89	P,S,T,Z
37	50	460	1475	65	420	0.89	P,S,T,Z
45	60	450	1475	79	540	0.9	P,S,T,Z
45	60	452	1475	79	540	0.9	P,S,T,Z
45	60	454	1475	79	540	0.9	P,S,T,Z
45	60	456	1475	79	540	0.9	P,S,T,Z
45	60	458	1475	79	540	0.9	P,S,T,Z
45	60	460	1475	79	540	0.9	P,S,T,Z

SH

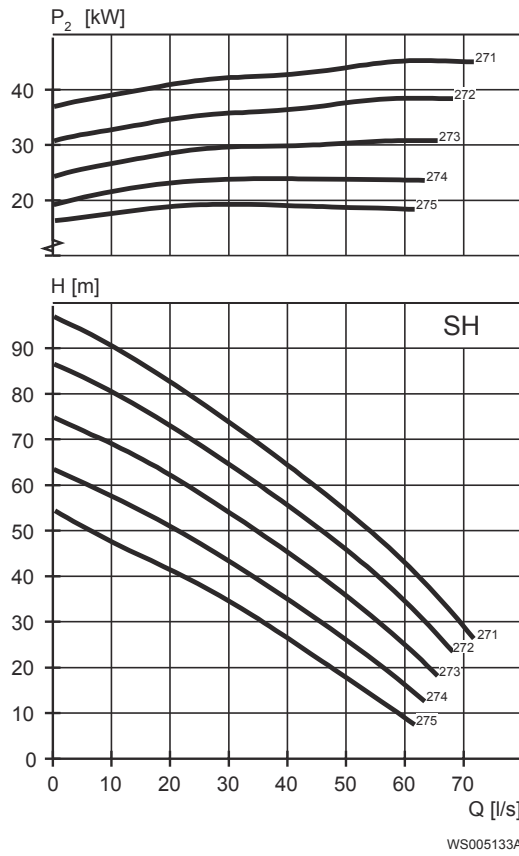

Table 5: 400 V, 50 Hz, 3-phase

Rated power, kW	Rated power, hp	Curve/ Impeller No	Revolutions per minute, rpm	Rated current, A	Starting current, A	Power factor, cos φ	Installation
47	63	271	2950	79	555	0.92	P,S
47	63	272	2950	79	555	0.92	P,S
47	63	273	2950	79	555	0.92	P,S
47	63	274	2950	79	555	0.92	P,S
47	63	275	2950	79	555	0.92	P,S



# F-pump, Premium Efficiency Motor (IE3)

## Product description



## Usage

A submersible chopper pump for heavily contaminated sewage and sludge. The N-hydraulic is fitted with a cutting insert ring. Both impeller and insert ring are manufactured in Hard-Iron™.

## Denomination

Type	Non-explosion proof version	Explosion proof version	Pressure class	Installation types
Hard-Iron™ Chopper	3202.840	3202.850	MT – Medium head HT – High head SH – Super head	P, S, T, Z

The pump can be used in the following installations:

- P Semi permanent, wet well arrangement with pump installed on two guide bars with automatic connection to discharge.
- S Portable semi permanent, wet well arrangement with hose coupling or flange for connection to discharge pipeline.
- T Vertical permanent, dry well arrangement with flange connection to suction and discharge piping.
- Z Horizontal permanent, dry well arrangement with flange connection to suction and discharge piping.

## Application limits

Feature	Description
Liquid temperature	Maximum 40°C (104°F)
Depth of immersion	Maximum 20 m (65 ft)
pH of the pumped liquid	5.5 - 14
Liquid density	Maximum 1100 kg/m <sup>3</sup>

Motor data

Feature	Description
Motor type	Squirrel-cage induction motor
Frequency	50 Hz
Power supply	3-phase
Starting method	<ul style="list-style-type: none"> <li>• Direct on-line</li> <li>• Star-delta</li> <li>• Variable Frequency Drive (VFD)</li> </ul>
Number of starts per hour	Maximum 30
Code compliance	IEC 60034-1
Voltage variation	<ul style="list-style-type: none"> <li>• Continuously running: Maximum <math>\pm 5\%</math></li> <li>• Intermittent running: Maximum <math>\pm 10\%</math></li> </ul>
Voltage imbalance between phases	Maximum 2%
Stator insulation class	H (180°C, 356°F)

Cables

Application	Type
Direct-on-line start or Y/D start with two cables	Flygt SUBCAB® - a heavy duty 4 cores motor power cable with two twisted pair screened control cores. Conductor insulation rating of 90°C, which allows for increased current. Superior mechanical strength and high abrasion and tear resistant. Chemical resistant within pH 3-10 and ozone, oil, and flame resistant. Used up to 70°C water temperature. Cables < 10 mm <sup>2</sup> with unscreened control cores.
Y/D start	Flygt SUBCAB® - a heavy duty 7 cores motor power cable with two twisted pair screened control cores. Conductor insulation rating of 90°C, which allows for increased current. Superior mechanical strength and high abrasion and tear resistant. Chemical resistant within pH 3-10 and ozone, oil, and flame resistant. Used up to 70°C water temperature. Cables < 7G6 mm <sup>2</sup> with unscreened control cores.
Variable Frequency drive	Screened Flygt SUBCAB® - a heavy duty 4 screened cores motor power cable with four twisted pair screened control cores. Conductor insulation rating of 90°C, which allows for increased current. Superior mechanical strength and high abrasion and tear resistant. Chemical resistant within pH 3-10 and ozone, oil, and flame resistant. Used up to 70°C water temperature.

Monitoring equipment

- Thermal contacts opening temperature 140° C (284° F)
- Leakage sensor in the inspection chamber (FLS 10)

Materials

Table 6: Major parts except mechanical seals

Denomination	Material	ASTM	EN
Major castings	Cast iron, gray	35B	GJL-250
Pump housing	Cast iron, gray	35B	GJL-250
Impeller	Cast iron, Hard-Iron™	A 532 IIIA	GJN-HB555(XCR23)

Denomination	Material	ASTM	EN
Insert ring	Cast iron, Hard-Iron™	A 532 IIIA	GJN-HB555(XCR23)
Cooling jacket, inner	Aluminum	AA 1050A	AW-1050A
Cooling jacket, outer	Stainless steel	AISI 316L	1.4404,1.4432, ...
Lifting handle	Stainless steel	AISI 316L	1.4404,1.4432, ...
Shaft	Stainless steel	AISI 431	1.4057+QT800
Screws and nuts	Stainless steel, A4	AISI 316L, 316, 316Ti	1.4401,1.4404, ...
O-rings, alternative 1	Nitrile rubber (NBR) 70° IRH	-	-
O-rings, alternative 2	Fluorinated rubber (FPM) 70° IRH	-	-
Glycol	Heat transfer fluid based on monopropylene glycol.	-	-

Table 7: Mechanical seals

Alternative	Inner seal	Outer seal
1	Corrosion resistant cemented carbide/ Corrosion resistant cemented carbide	Corrosion resistant cemented carbide/ Corrosion resistant cemented carbide
2	Corrosion resistant cemented carbide/ Corrosion resistant cemented carbide	Silicon carbide/ Silicon carbide

### Surface treatment

Priming	Finish
Painted with a primer, see internal standard M0700.00.0002	Navy gray color NCS 5804-B07G. Two-component high-solid top coating, see internal standard M0700.00.0004 for standard painting and M0700.00.0008 for special painting.

### Options

- Sensors: Thermistor, FLS, PT 100, VIS 10
- Pump memory
- Surface treatment (Epoxy)
- Zinc anodes
- Other cables

### Accessories

Discharge connections, adapters, hose connections, and other mechanical accessories. Electrical accessories such as pump controller, control panels, starters, monitoring relays, cables.

## Motor rating and performance curves

These are examples of motor rating and curves. For more information, please contact your local sales and service representative.

Star-delta starting current is 1/3 of Direct on-line starting current.

MT

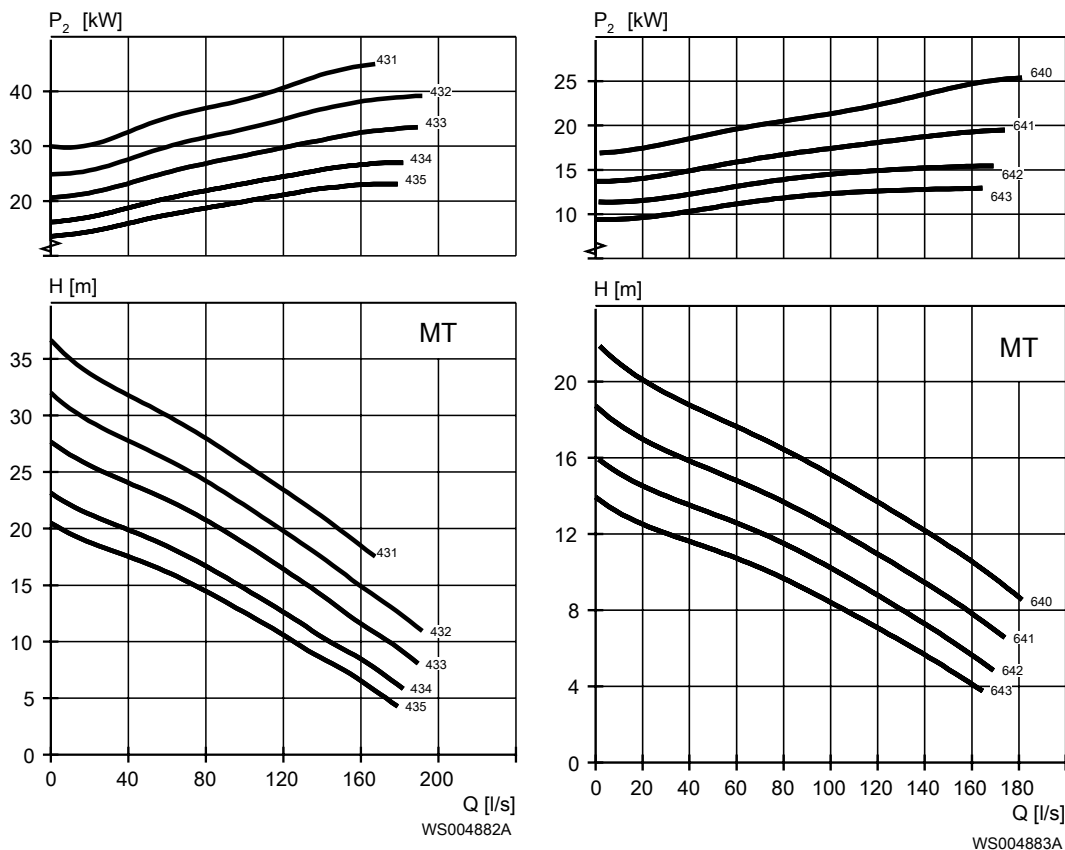

Table 8: 400 V, 50 Hz, 3-phase

Rated power, kW	Rated power, hp	Curve/ Impeller No	Revolutions per minute, rpm	Rated Current, A	Start current, A	Power factor, cos φ	Installation
23	31	641	980	45	270	0.79	P,S,T,Z
23	31	642	980	45	270	0.79	P,S,T,Z
23	31	643	980	45	270	0.79	P,S,T,Z
30	40	434	1485	57	425	0.82	P,S,T,Z
30	40	435	1485	57	425	0.82	P,S,T,Z
31	42	640	980	60	360	0.81	P,S,T,Z
31	42	641	980	60	360	0.81	P,S,T,Z
31	42	642	980	60	360	0.81	P,S,T,Z
31	42	643	980	60	360	0.81	P,S,T,Z
37	50	433	1485	73	540	0.78	P,S,T,Z
37	50	434	1485	73	540	0.78	P,S,T,Z
37	50	435	1485	73	540	0.78	P,S,T,Z
38	51	640	980	77	495	0.77	P,S,T,Z
38	51	641	980	77	495	0.77	P,S,T,Z
38	51	642	980	77	495	0.77	P,S,T,Z
38	51	643	980	77	495	0.77	P,S,T,Z
45	60	431	1480	81	585	0.85	P,S,T,Z
45	60	432	1480	81	585	0.85	P,S,T,Z

Rated power, kW	Rated power, hp	Curve/ Impeller No	Revolutions per minute, rpm	Rated Current, A	Start current, A	Power factor, cos φ	Installation
45	60	433	1480	81	585	0.85	P,S,T,Z
45	60	434	1480	81	585	0.85	P,S,T,Z
45	60	435	1480	81	585	0.85	P,S,T,Z

HT

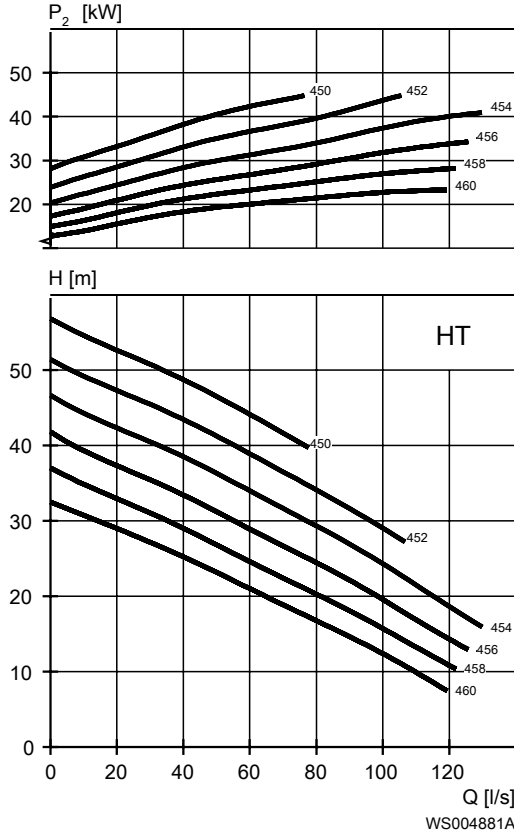

Table 9: 400 V, 50 Hz, 3-phase

Rated power, kW	Rated power, hp	Curve/ Impeller No	Revolutions per minute, rpm	Rated Current, A	Start current, A	Power factor, cos φ	Installation
30	40	456	1485	57	425	0.82	P,S,T,Z
30	40	458	1485	57	425	0.82	P,S,T,Z
30	40	460	1485	57	425	0.82	P,S,T,Z
37	50	456	1485	73	540	0.78	P,S,T,Z
37	50	458	1485	73	540	0.78	P,S,T,Z
37	50	460	1485	73	540	0.78	P,S,T,Z
45	60	450	1480	81	585	0.85	P,S,T,Z
45	60	452	1480	81	585	0.85	P,S,T,Z
45	60	454	1480	81	585	0.85	P,S,T,Z
45	60	456	1480	81	585	0.85	P,S,T,Z
45	60	458	1480	81	585	0.85	P,S,T,Z
45	60	460	1480	81	585	0.85	P,S,T,Z

SH

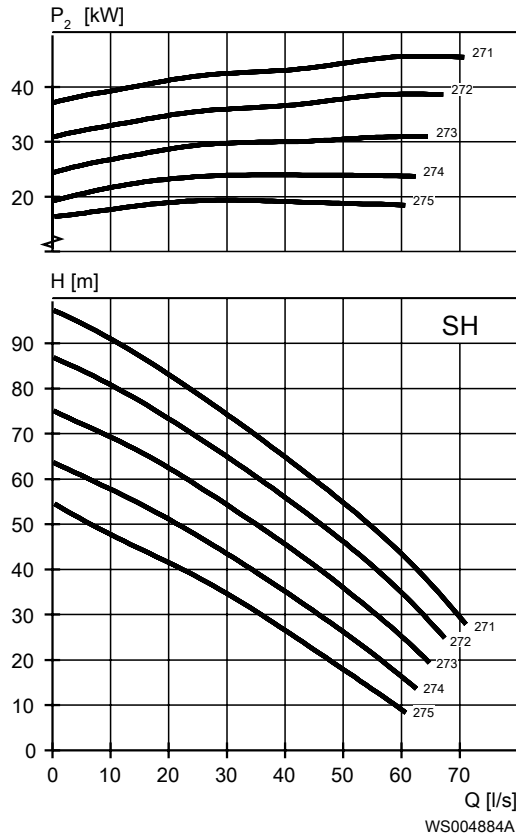

Table 10: 400 V, 50 Hz, 3-phase

Rated power, kW	Rated power, hp	Curve/ Impeller No	Revolutions per minute, rpm	Rated Current, A	Start current, A	Power factor, $\cos \varphi$	Installation
47	63	271	2960	82	660	0.88	P,S,T,Z
47	63	272	2960	82	660	0.88	P,S
47	63	273	2960	82	660	0.88	P,S,T,Z
47	63	274	2960	82	660	0.88	P,S,T,Z
47	63	275	2960	82	660	0.88	P,S

# N-pump, Standard Motor

## Product description



## Usage

A submersible pump for efficient pumping of clean water, surface water, and wastewater containing solids or long-fibered material. The pump is designed for sustained high efficiency. For abrasive media, Hard-Iron™ is required. Stainless steel N-impeller is available as an option.

## Denomination

Type	Non-explosion proof version	Explosion proof version	Pressure class	Installation types
Cast iron	3202.180	3202.090	LT – Low head MT – Medium head HT – High head	P, S, T, Z
Hard-Iron™	3202.185	3202.095	LT – Low head MT – Medium head HT – High head SH – Super head	P, S, T, Z
Stainless steel	3202.660	3202.670	MT – Medium head HT – High head	P, S

The pump can be used in the following installations:

- P Semi permanent, wet well arrangement with pump installed on two guide bars with automatic connection to discharge.
- S Portable semi permanent, wet well arrangement with hose coupling or flange for connection to discharge pipeline.
- T Vertical permanent, dry well arrangement with flange connection to suction and discharge piping.
- Z Horizontal permanent, dry well arrangement with flange connection to suction and discharge piping.

## Application limits

Feature	Description
Liquid temperature	Maximum 40°C (104°F)

Feature	Description
Liquid temperature, warm water version	Maximum 70°C (158°F)
Depth of immersion	Maximum 20 m (65 ft)
pH of the pumped liquid	5.5 - 14
Liquid density	Maximum 1100 kg/m <sup>3</sup>

Motor data

Feature	Description
Motor type	Squirrel-cage induction motor
Frequency	50 Hz
Power supply	3-phase
Starting method	<ul style="list-style-type: none"> <li>• Direct on-line</li> <li>• Star-delta</li> <li>• Variable Frequency Drive (VFD)</li> </ul>
Number of starts per hour	Maximum 30
Code compliance	IEC 60034-1
Voltage variation	<ul style="list-style-type: none"> <li>• Continuously running: Maximum ±5%</li> <li>• Intermittent running: Maximum ±10%</li> </ul>
Voltage imbalance between phases	Maximum 2%
Stator insulation class	H (180°C, 356°F)

Cables

Application	Type
Direct-on-line start or Y/D start with two cables	Flygt SUBCAB® - a heavy duty 4 cores motor power cable with two twisted pair screened control cores. Conductor insulation rating of 90°C, which allows for increased current. Superior mechanical strength and high abrasion and tear resistant. Chemical resistant within pH 3-10 and ozone, oil, and flame resistant. Used up to 70°C water temperature. Cables < 10 mm <sup>2</sup> with unscreened control cores.
Y/D start	Flygt SUBCAB® - a heavy duty 7 cores motor power cable with two twisted pair screened control cores. Conductor insulation rating of 90°C, which allows for increased current. Superior mechanical strength and high abrasion and tear resistant. Chemical resistant within pH 3-10 and ozone, oil, and flame resistant. Used up to 70°C water temperature. Cables < 7G6 mm <sup>2</sup> with unscreened control cores.
Variable Frequency drive	Screened Flygt SUBCAB® - a heavy duty 4 screened cores motor power cable with four twisted pair screened control cores. Conductor insulation rating of 90°C, which allows for increased current. Superior mechanical strength and high abrasion and tear resistant. Chemical resistant within pH 3-10 and ozone, oil, and flame resistant. Used up to 70°C water temperature.

Monitoring equipment

- Thermal contacts opening temperature 140° C (284° F)
- Leakage sensor in the inspection chamber (FLS 10)



## Materials

Table 11: Major parts except mechanical seals

Denomination	Material	ASTM	EN
Major castings	Cast iron, gray	35B	GJL-250
Pump housing	Cast iron, gray	35B	GJL-250
Impeller, alternative 1	Cast iron, gray	35B	GJL-250
Impeller, alternative 2	Cast iron, Hard-Iron™	A 532 IIIA	GJN-HB555(XCR23)
Impeller, alternative 3	Stainless steel, Duplex	CD-4MCuN	10283:2010 -1.4474
Insert ring, alternative 1	Cast iron, gray	35B	GJL-250
Insert ring, alternative 2	Cast iron, Hard-Iron™	A 532 IIIA	GJN-HB555(XCR23)
Cooling jacket, inner	Aluminum	AA 1050A	AW-1050A
Cooling jacket, outer, alternative 1	Steel	GR65	S235JRG2
Cooling jacket, outer, alternative 2	Stainless steel	AISI 316L	1.4404, 1.4432, ...
Lifting handle	Stainless steel	AISI 316L	1.4404, 1.4432, ...
Shaft	Stainless steel	AISI 431	1.4057+QT800
Screws and nuts	Stainless steel, A4	AISI 316L, 316, 316Ti	1.4401, 1.4404, ...
O-rings, alternative 1	Nitrile rubber (NBR) 70° IRH	-	-
O-rings, alternative 2	Fluorinated rubber (FPM) 70° IRH	-	-
Glycol	Heat transfer fluid based on monopropylene glycol.	-	-

Table 12: Mechanical seals

Alternative	Inner seal	Outer seal
1	Corrosion resistant cemented carbide/ Corrosion resistant cemented carbide	Corrosion resistant cemented carbide/ Corrosion resistant cemented carbide
2	Corrosion resistant cemented carbide/ Corrosion resistant cemented carbide	Silicon carbide/ Silicon carbide

## Surface treatment

Priming	Finish
Painted with a primer, see internal standard M0700.00.0002	Navy gray color NCS 5804-B07G. Two-component high-solid top coating, see internal standard M0700.00.0004 for standard painting and M0700.00.0008 for special painting.

## Options

- Warm liquid version (non-explosion proof versions)
- Sensors: Thermistor, FLS, PT 100, VIS 10
- Pump memory
- Surface treatment (Epoxy)
- Zinc anodes
- Other cables

Accessories

Discharge connections, adapters, hose connections, and other mechanical accessories.  
Electrical accessories such as pump controller, control panels, starters, monitoring relays, cables.

## Motor rating and performance curves 3202.180/.090/.185/.095

These are examples of motor rating and curves. For more information, please contact your local sales and service representative.

Star-delta starting current is 1/3 of Direct on-line starting current.

LT

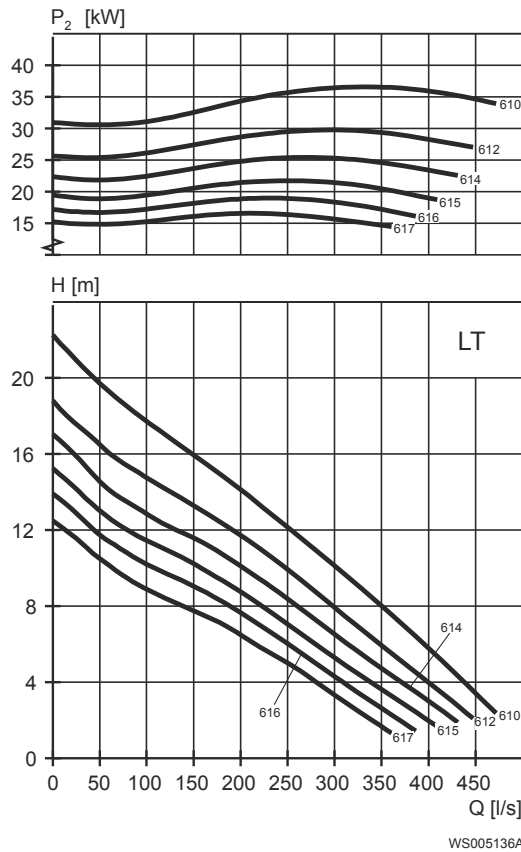

Table 13: 400 V, 50 Hz, 3-phase

Rated power, kW	Rated power, hp	Curve/ Impeller No	Revolutions per minute, rpm	Rated current, A	Starting current, A	Power factor, $\cos \varphi$	Installation
22	30	615	970	43	238	0.84	P,S,T,Z
22	30	616	970	43	238	0.84	P,S,T,Z
22	30	617	970	43	238	0.84	P,S,T,Z
30	40	612	970	59	320	0.83	P,S,T,Z
30	40	614	970	59	320	0.83	P,S,T,Z
30	40	615	970	59	320	0.83	P,S,T,Z
30	40	616	970	59	320	0.83	P,S,T,Z
30	40	617	970	59	320	0.83	P,S,T,Z
37	50	610	970	71	405	0.83	P,S,T,Z
37	50	612	970	71	405	0.83	P,S,T,Z

Rated power, kW	Rated power, hp	Curve/ Impeller No	Revolutions per minute, rpm	Rated current, A	Starting current, A	Power factor, cos φ	Installation
37	50	614	970	71	405	0.83	P,S,T,Z
37	50	615	970	71	405	0.83	P,S,T,Z
37	50	616	970	71	405	0.83	P,S,T,Z
37	50	617	970	71	405	0.83	P,S,T,Z

MT

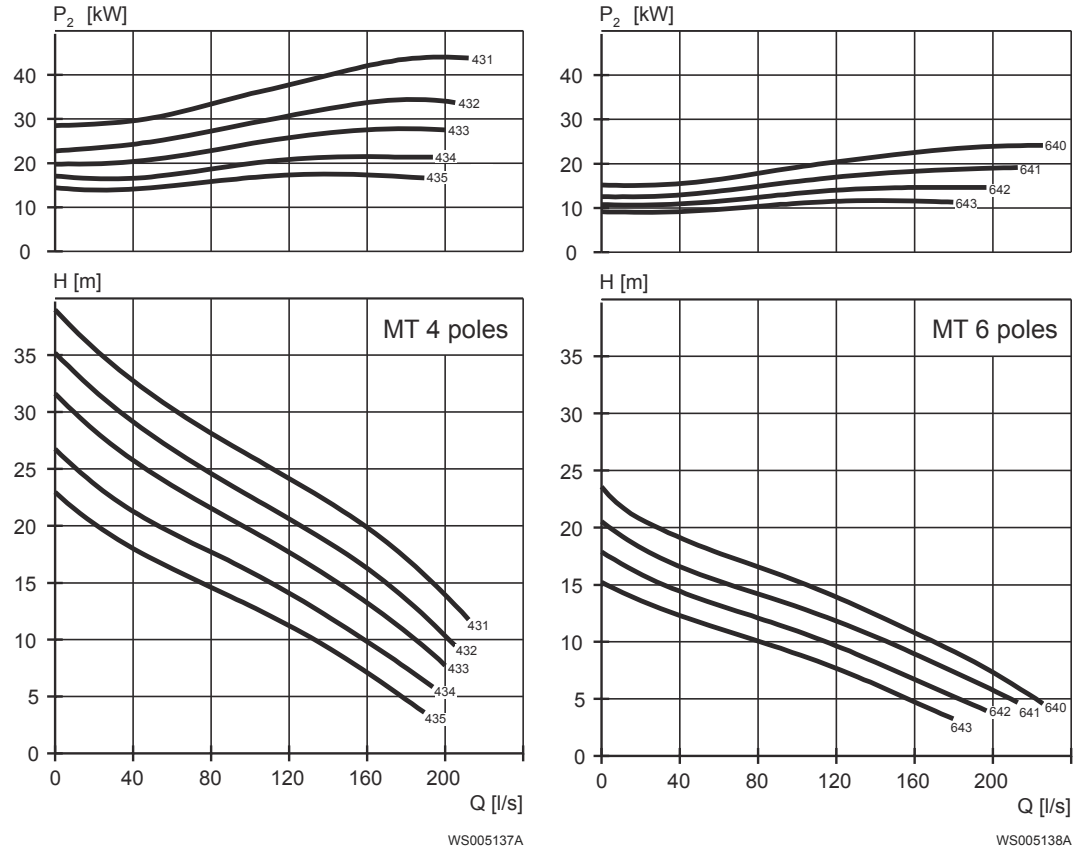

Table 14: 400 V, 50 Hz, 3-phase

Rated power, kW	Rated power, hp	Curve/ Impeller No	Revolutions per minute, rpm	Rated current, A	Starting current, A	Power factor, cos φ	Installation
22	30	640	970	43	238	0.84	P,S,T,Z
22	30	641	970	43	238	0.84	P,S,T,Z
22	30	642	970	43	238	0.84	P,S,T,Z
22	30	643	970	43	238	0.84	P,S,T,Z
30	40	433	1475	54	360	0.88	P,S,T,Z
30	40	434	1475	54	360	0.88	P,S,T,Z
30	40	435	1475	54	360	0.88	P,S,T,Z
30	40	640	970	59	320	0.83	P,S,T,Z
30	40	641	970	59	320	0.83	P,S,T,Z
30	40	642	970	59	320	0.83	P,S,T,Z
30	40	643	970	59	320	0.83	P,S,T,Z

Rated power, kW	Rated power, hp	Curve/ Impeller No	Revolutions per minute, rpm	Rated current, A	Starting current, A	Power factor, cos φ	Installation
37	50	432	1475	65	420	0.89	P,S,T,Z
37	50	433	1475	65	420	0.89	P,S,T,Z
37	50	434	1475	65	420	0.89	P,S,T,Z
37	50	435	1475	65	420	0.89	P,S,T,Z
37	50	640	970	71	405	0.83	P,S,T,Z
37	50	641	970	71	405	0.83	P,S,T,Z
37	50	642	970	71	405	0.83	P,S,T,Z
37	50	643	970	71	405	0.83	P,S,T,Z
45	60	431	1475	79	540	0.9	P,S,T,Z
45	60	432	1475	79	540	0.9	P,S,T,Z
45	60	433	1475	79	540	0.9	P,S,T,Z
45	60	434	1475	79	540	0.9	P,S,T,Z
45	60	435	1475	79	540	0.9	P,S,T,Z

HT

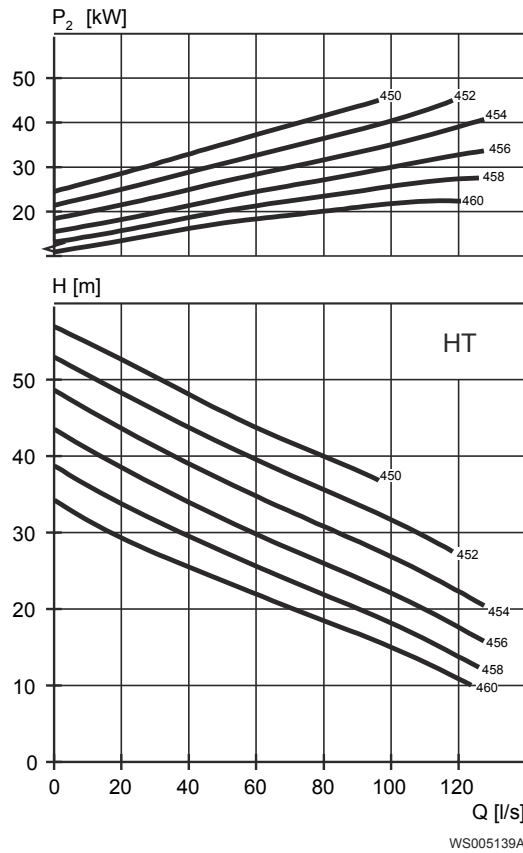

Table 15: 400 V, 50 Hz, 3-phase

Rated power, kW	Rated power, hp	Curve/ Impeller No	Revolutions per minute, rpm	Rated current, A	Starting current, A	Power factor, cos φ	Installation
30	40	454	1475	54	360	0.88	P,S,T,Z
30	40	456	1475	54	360	0.88	P,S,T,Z
30	40	458	1475	54	360	0.88	P,S,T,Z

Rated power, kW	Rated power, hp	Curve/ Impeller No	Revolutions per minute, rpm	Rated current, A	Starting current, A	Power factor, cos φ	Installation
30	40	460	1475	54	360	0.88	P,S,T,Z
37	50	450	1475	65	420	0.89	P,S,T,Z
37	50	452	1475	65	420	0.89	P,S,T,Z
37	50	454	1475	65	420	0.89	P,S,T,Z
37	50	456	1475	65	420	0.89	P,S,T,Z
37	50	458	1475	65	420	0.89	P,S,T,Z
37	50	460	1475	65	420	0.89	P,S,T,Z
45	60	450	1475	79	540	0.9	P,S,T,Z
45	60	452	1475	79	540	0.9	P,S,T,Z
45	60	454	1475	79	540	0.9	P,S,T,Z
45	60	456	1475	79	540	0.9	P,S,T,Z
45	60	458	1475	79	540	0.9	P,S,T,Z
45	60	460	1475	79	540	0.9	P,S,T,Z

SH

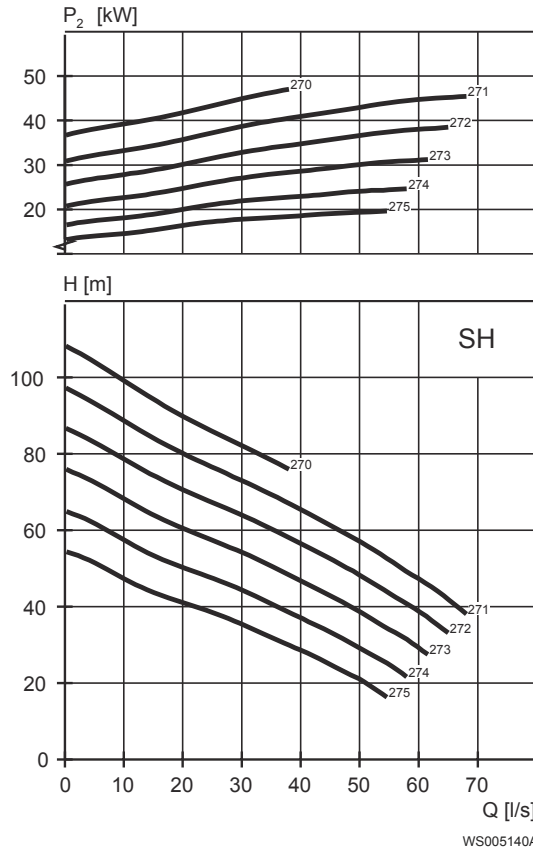

Table 16: 400 V, 50 Hz, 3-phase

Rated power, kW	Rated power, hp	Curve/ Impeller No	Revolutions per minute, rpm	Rated current, A	Starting current, A	Power factor, cos φ	Installation
47	63	270 <sup>1</sup>	2950	79	555	0.92	P,S,T,Z

<sup>1</sup> Only applicable for 3202.185 and 3202.095

Rated power, kW	Rated power, hp	Curve/ Impeller No	Revolutions per minute, rpm	Rated current, A	Starting current, A	Power factor, cos φ	Installation
47	63	271 <sup>1</sup>	2950	79	555	0.92	P,S,T,Z
47	63	272 <sup>1</sup>	2950	79	555	0.92	P,S,T,Z
47	63	273 <sup>1</sup>	2950	79	555	0.92	P,S,T,Z
47	63	274 <sup>1</sup>	2950	79	555	0.92	P,S,T,Z
47	63	275 <sup>1</sup>	2950	79	555	0.92	P,S,T,Z

## Motor rating and performance curves 3202.660/.670

These are examples of motor rating and curves. For more information, please contact your local sales and service representative.

Star-delta starting current is 1/3 of Direct on-line starting current.

MT

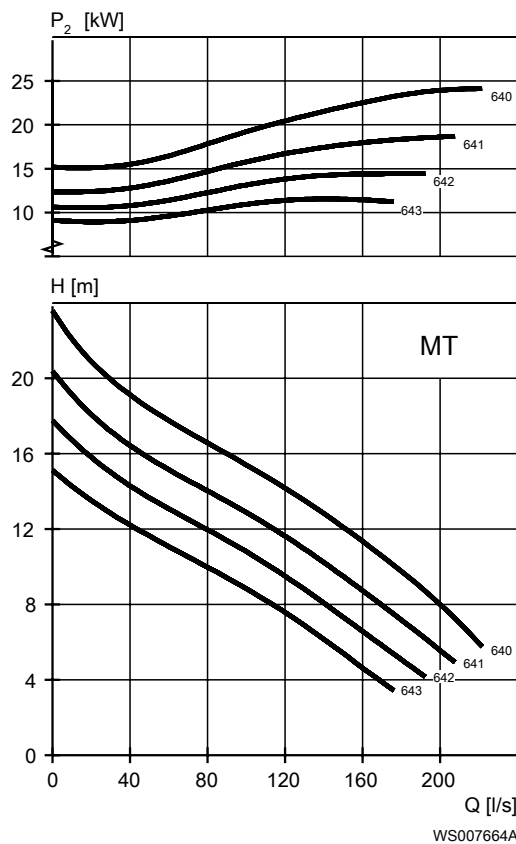

Table 17: 400 V, 50 Hz, 3-phase

Rated power, kW	Rated power, hp	Curve/ Impeller No	Revolutions per minute, rpm	Rated Current, A	Start current, A	Power Factor, cos φ	Installation
22	30	641	970	43	235	0.84	P,S
22	30	642	970	43	235	0.84	P,S
22	30	643	970	43	235	0.84	P,S
30	40	640	970	58	320	0.83	P,S
30	40	641	970	58	320	0.83	P,S
30	40	642	970	58	320	0.83	P,S

Rated power, kW	Rated power, hp	Curve/ Impeller No	Revolutions per minute, rpm	Rated Current, A	Start current, A	Power Factor, cos φ	Installation
30	40	643	970	58	320	0.83	P,S
37	50	640	970	71	415	0.84	P,S
37	50	641	970	71	415	0.84	P,S
37	50	642	970	71	415	0.84	P,S
37	50	643	970	71	415	0.84	P,S

HT

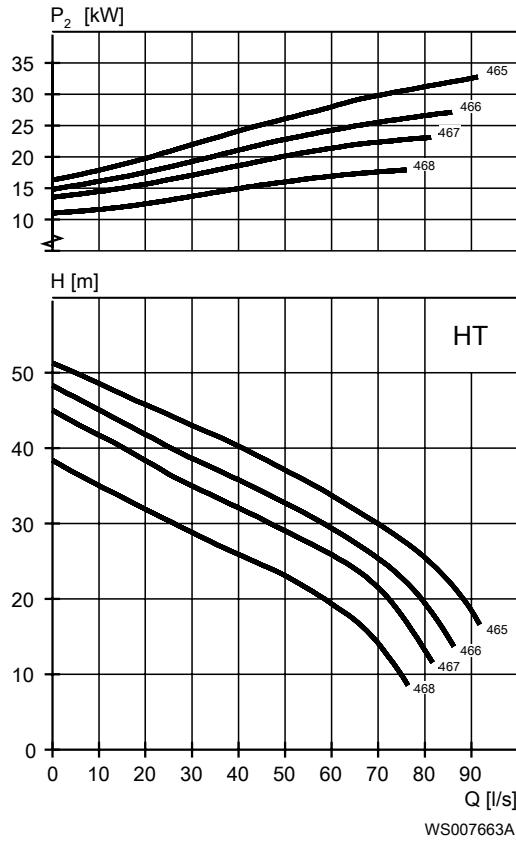

Table 18: 400 V, 50 Hz, 3-phase

Rated power, kW	Rated power, hp	Curve/ Impeller No	Revolutions per minute, rpm	Rated Current, A	Start current, A	Power Factor, cos φ	Installation
30	40	466	1475	54	360	0.88	P,S
30	40	467	1475	54	360	0.88	P,S
30	40	468	1475	54	360	0.88	P,S
37	50	465	1475	65	420	0.89	P,S
37	50	466	1475	65	420	0.89	P,S
37	50	467	1475	65	420	0.89	P,S
37	50	468	1475	65	420	0.89	P,S
45	60	465	1475	79	540	0.9	P,S
45	60	466	1475	79	540	0.9	P,S
45	60	467	1475	79	540	0.9	P,S
45	60	468	1475	79	540	0.9	P,S

# N-pump, Premium Efficiency Motor (IE3)

## Product description



### Usage

A submersible pump for efficient pumping of clean water, surface water, and wastewater containing solids or long-fibered material. The pump is designed for sustained high efficiency. For abrasive media, Hard-Iron™ is required. Stainless steel N-impeller is available as an option.

### Denomination

Type	Non-explosion proof version	Explosion proof version	Pressure class	Installation types
Cast iron	3202.800	3202.810	LT – Low head MT – Medium head HT – High head	P, S, T, Z
Hard-Iron™	3202.820	3202.830	LT – Low head MT – Medium head HT – High head SH – Super head	P, S, T, Z
Stainless steel	3202.860	3202.870	MT – Medium head HT – High head	P, S

The pump can be used in the following installations:

- P Semi permanent, wet well arrangement with pump installed on two guide bars with automatic connection to discharge.
- S Portable semi permanent, wet well arrangement with hose coupling or flange for connection to discharge pipeline.
- T Vertical permanent, dry well arrangement with flange connection to suction and discharge piping.
- Z Horizontal permanent, dry well arrangement with flange connection to suction and discharge piping.



### Application limits

Feature	Description
Liquid temperature	Maximum 40°C (104°F)
Depth of immersion	Maximum 20 m (65 ft)
pH of the pumped liquid	5.5 - 14
Liquid density	Maximum 1100 kg/m <sup>3</sup>

### Motor data

Feature	Description
Motor type	Squirrel-cage induction motor
Frequency	50 Hz
Power supply	3-phase
Starting method	<ul style="list-style-type: none"> <li>• Direct on-line</li> <li>• Star-delta</li> <li>• Variable Frequency Drive (VFD)</li> </ul>
Number of starts per hour	Maximum 30
Code compliance	IEC 60034-1
Voltage variation	<ul style="list-style-type: none"> <li>• Continuously running: Maximum <math>\pm 5\%</math></li> <li>• Intermittent running: Maximum <math>\pm 10\%</math></li> </ul>
Voltage imbalance between phases	Maximum 2%
Stator insulation class	H (180°C, 356°F)

### Cables

Application	Type
Direct-on-line start or Y/D start with two cables	Flygt SUBCAB® - a heavy duty 4 cores motor power cable with two twisted pair screened control cores. Conductor insulation rating of 90°C, which allows for increased current. Superior mechanical strength and high abrasion and tear resistant. Chemical resistant within pH 3-10 and ozone, oil, and flame resistant. Used up to 70°C water temperature. Cables < 10 mm <sup>2</sup> with unscreened control cores.
Y/D start	Flygt SUBCAB® - a heavy duty 7 cores motor power cable with two twisted pair screened control cores. Conductor insulation rating of 90°C, which allows for increased current. Superior mechanical strength and high abrasion and tear resistant. Chemical resistant within pH 3-10 and ozone, oil, and flame resistant. Used up to 70°C water temperature. Cables < 7G6 mm <sup>2</sup> with unscreened control cores.
Variable Frequency drive	Screened Flygt SUBCAB® - a heavy duty 4 screened cores motor power cable with four twisted pair screened control cores. Conductor insulation rating of 90°C, which allows for increased current. Superior mechanical strength and high abrasion and tear resistant. Chemical resistant within pH 3-10 and ozone, oil, and flame resistant. Used up to 70°C water temperature.

### Monitoring equipment

- Thermal contacts opening temperature 140° C (284° F)
- Leakage sensor in the inspection chamber (FLS 10)

Materials

Table 19: Major parts except mechanical seals

Denomination	Material	ASTM	EN
Major castings	Cast iron, gray	35B	GJL-250
Pump housing	Cast iron, gray	35B	GJL-250
Impeller, alternative 1	Cast iron, gray	35B	GJL-250
Impeller, alternative 2	Cast iron, Hard-Iron™	A 532 IIIA	GJN-HB555(XCR23)
Impeller, alternative 3	Stainless steel, Duplex	CD-4MCuN	10283:2010 -1.4474
Insert ring, alternative 1	Cast iron, gray	35B	GJL-250
Insert ring, alternative 2	Cast iron, Hard-Iron™	A 532 IIIA	GJN-HB555(XCR23)
Cooling jacket, inner	Aluminum	AA 1050A	AW-1050A
Cooling jacket, outer	Stainless steel	AISI 316L	1.4404,1.4432, ...
Lifting handle	Stainless steel	AISI 316L	1.4404,1.4432, ...
Shaft	Stainless steel	AISI 431	1.4057+QT800
Screws and nuts	Stainless steel, A4	AISI 316L, 316, 316Ti	1.4401,1.4404, ...
O-rings, alternative 1	Nitrile rubber (NBR) 70° IRH	-	-
O-rings, alternative 2	Fluorinated rubber (FPM) 70° IRH	-	-
Glycol	Heat transfer fluid based on monopropylene glycol.	-	-

Table 20: Mechanical seals

Alternative	Inner seal	Outer seal
1	Corrosion resistant cemented carbide/ Corrosion resistant cemented carbide	Corrosion resistant cemented carbide/ Corrosion resistant cemented carbide
2	Corrosion resistant cemented carbide/ Corrosion resistant cemented carbide	Silicon carbide/ Silicon carbide

Surface treatment

Priming	Finish
Painted with a primer, see internal standard M0700.00.0002	Navy gray color NCS 5804-B07G. Two-component high-solid top coating, see internal standard M0700.00.0004 for standard painting and M0700.00.0008 for special painting.

Options

- Sensors: Thermistor, FLS, PT 100, VIS 10
- Pump memory
- Surface treatment (Epoxy)
- Zinc anodes
- Other cables

Accessories

Discharge connections, adapters, hose connections, and other mechanical accessories. Electrical accessories such as pump controller, control panels, starters, monitoring relays, cables.

# Motor rating and performance curves 3202.800/.810

These are examples of motor rating and curves. For more information, please contact your local sales and service representative.

Star-delta starting current is 1/3 of Direct on-line starting current.

LT

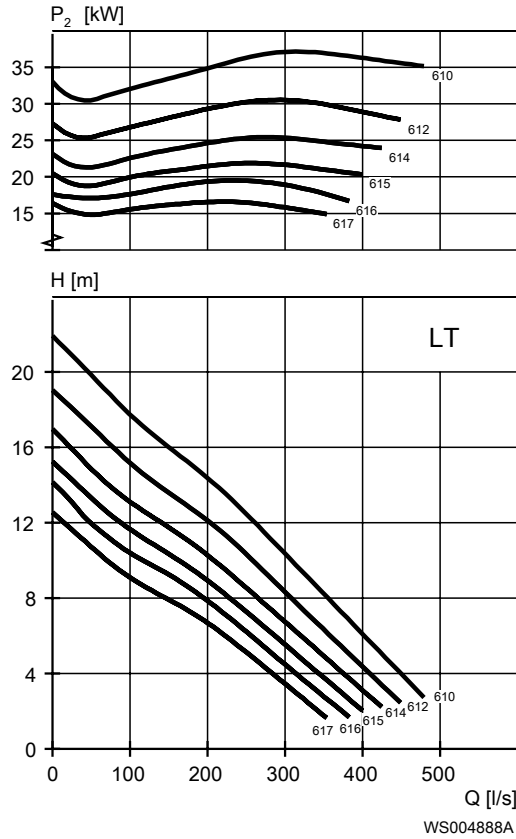
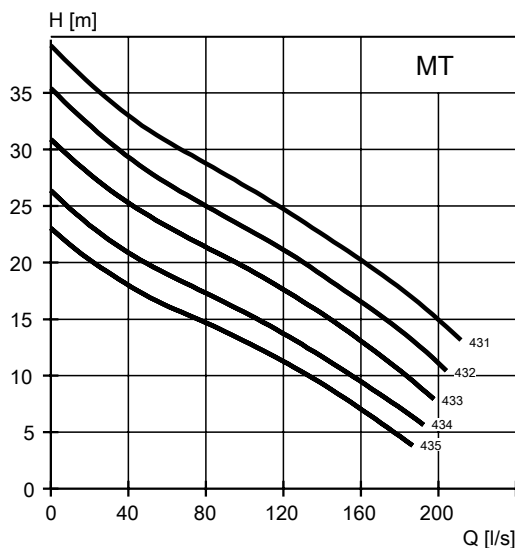
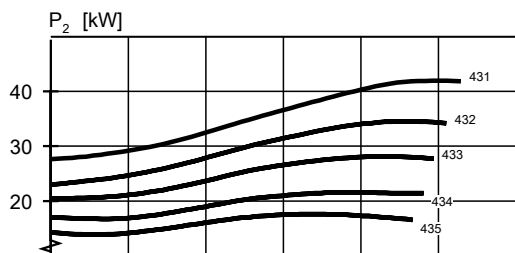

Table 21: 400 V, 50 Hz, 3-phase

Rated power, kW	Rated power, hp	Curve/ Impeller No	Revolutions per minute, rpm	Rated Current, A	Start current, A	Power factor, cos $\phi$	Installation
23	31	615	980	45	270	0.79	P,S,T,Z
23	31	616	980	45	270	0.79	P,S,T,Z
23	31	617	980	45	270	0.79	P,S,T,Z
31	42	612	980	60	360	0.81	P,S,T,Z
31	42	614	980	60	360	0.81	P,S,T,Z
31	42	615	980	60	360	0.81	P,S,T,Z
31	42	616	980	60	360	0.81	P,S,T,Z
31	42	617	980	60	360	0.81	P,S,T,Z
38	51	610	980	77	495	0.77	P,S,T,Z
38	51	612	980	77	495	0.77	P,S,T,Z
38	51	614	980	77	495	0.77	P,S,T,Z
38	51	615	980	77	495	0.77	P,S,T,Z
38	51	616	980	77	495	0.77	P,S,T,Z
38	51	617	980	77	495	0.77	P,S,T,Z

MT



WS004889A

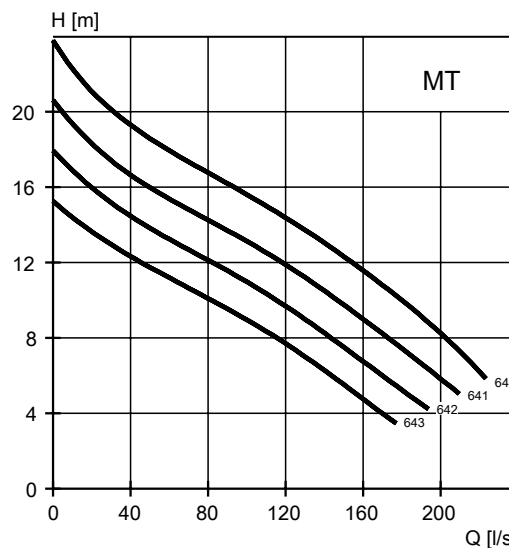
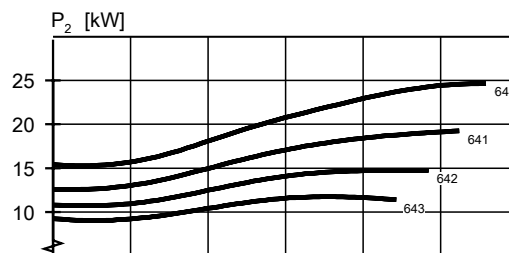

WS004890A

Table 22: 400 V, 50 Hz, 3-phase

Rated power, kW	Rated power, hp	Curve/ Impeller No	Revolutions per minute, rpm	Rated Current, A	Start current, A	Power factor, cos φ	Installation
23	31	640	980	45	270	0.79	P,S,T,Z
23	31	641	980	45	270	0.79	P,S,T,Z
23	31	642	980	45	270	0.79	P,S,T,Z
23	31	643	980	45	270	0.79	P,S,T,Z
30	40	433	1480	52	385	0.89	P,S,T,Z
30	40	434	1480	52	385	0.89	P,S,T,Z
30	40	435	1480	52	385	0.89	P,S,T,Z
31	42	640	980	60	360	0.81	P,S,T,Z
31	42	641	980	60	360	0.81	P,S,T,Z
31	42	642	980	60	360	0.81	P,S,T,Z
31	42	643	980	60	360	0.81	P,S,T,Z
37	50	432	1485	65	535	0.87	P,S,T,Z
37	50	433	1485	65	535	0.87	P,S,T,Z
37	50	434	1485	65	535	0.87	P,S,T,Z
37	50	435	1485	65	535	0.87	P,S,T,Z
38	51	640	980	77	495	0.77	P,S,T,Z
38	51	641	980	77	495	0.77	P,S,T,Z
38	51	642	980	77	495	0.77	P,S,T,Z

Rated power, kW	Rated power, hp	Curve/ Impeller No	Revolutions per minute, rpm	Rated Current, A	Start current, A	Power factor, cos φ	Installation
38	51	643	980	77	495	0.77	P,S,T,Z
45	60	431	1480	81	585	0.85	P,S,T,Z
45	60	432	1480	81	585	0.85	P,S,T,Z
45	60	433	1480	81	585	0.85	P,S,T,Z
45	60	434	1480	81	585	0.85	P,S,T,Z
45	60	435	1480	81	585	0.85	P,S,T,Z

HT

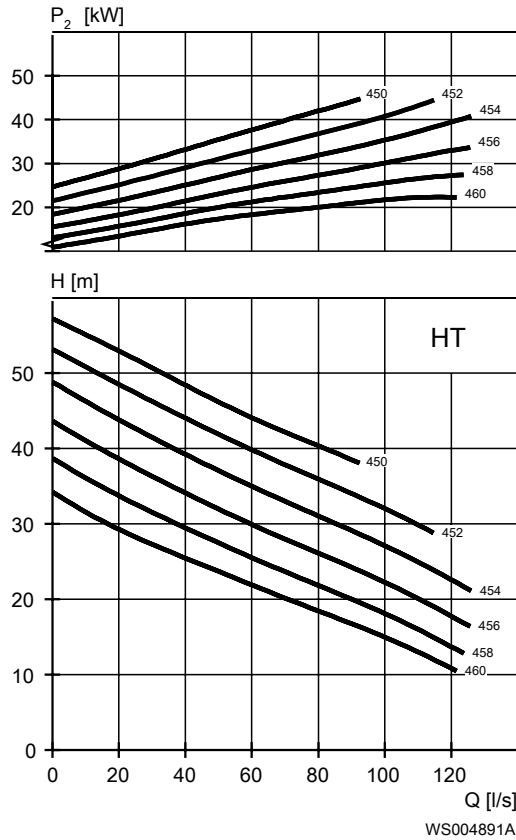

Table 23: 400 V, 50 Hz, 3-phase

Rated power, kW	Rated power, hp	Curve/ Impeller No	Revolutions per minute, rpm	Rated Current, A	Start current, A	Power factor, cos φ	Installation
30	40	454	1480	52	385	0.89	P,S,T,Z
30	40	456	1480	52	385	0.89	P,S,T,Z
30	40	458	1480	52	385	0.89	P,S,T,Z
30	40	460	1480	52	385	0.89	P,S,T,Z
37	50	450	1485	65	535	0.87	P,S,T,Z
37	50	452	1485	65	535	0.87	P,S,T,Z
37	50	454	1485	65	535	0.87	P,S,T,Z
37	50	456	1485	65	535	0.87	P,S,T,Z
37	50	458	1485	65	535	0.87	P,S,T,Z
37	50	460	1485	65	535	0.87	P,S,T,Z

Rated power, kW	Rated power, hp	Curve/ Impeller No	Revolutions per minute, rpm	Rated Current, A	Start current, A	Power factor, cos φ	Installation
45	60	450	1480	81	585	0.85	P,S,T,Z
45	60	452	1480	81	585	0.85	P,S,T,Z
45	60	454	1480	81	585	0.85	P,S,T,Z
45	60	456	1480	81	585	0.85	P,S,T,Z
45	60	458	1480	81	585	0.85	P,S,T,Z
45	60	460	1480	81	585	0.85	P,S,T,Z

## Motor rating and performance curves 3202.820/.830

These are examples of motor rating and curves. For more information, please contact your local sales and service representative.

Star-delta starting current is 1/3 of Direct on-line starting current.

LT

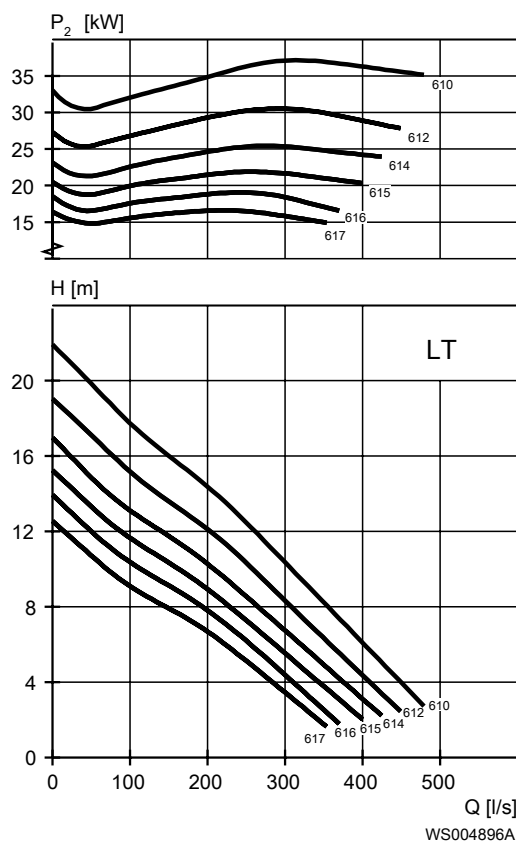

Table 24: 400 V, 50 Hz, 3-phase

Rated power, kW	Rated power, hp	Curve/ Impeller No	Revolutions per minute, rpm	Rated Current, A	Start current, A	Power factor, cos φ	Installation
23	31	615	980	45	270	0.79	P,S,T,Z
23	31	616	980	45	270	0.79	P,S,T,Z
23	31	617	980	45	270	0.79	P,S,T,Z
31	42	612	980	60	360	0.81	P,S,T,Z
31	42	614	980	60	360	0.81	P,S,T,Z
31	42	615	980	60	360	0.81	P,S,T,Z

Rated power, kW	Rated power, hp	Curve/ Impeller No	Revolutions per minute, rpm	Rated Current, A	Start current, A	Power factor, cos φ	Installation
31	42	616	980	60	360	0.81	P,S,T,Z
31	42	617	980	60	360	0.81	P,S,T,Z
38	51	610	980	77	495	0.77	P,S,T,Z
38	51	612	980	77	495	0.77	P,S,T,Z
38	51	614	980	77	495	0.77	P,S,T,Z
38	51	615	980	77	495	0.77	P,S,T,Z
38	51	616	980	77	495	0.77	P,S,T,Z
38	51	617	980	77	495	0.77	P,S,T,Z

MT

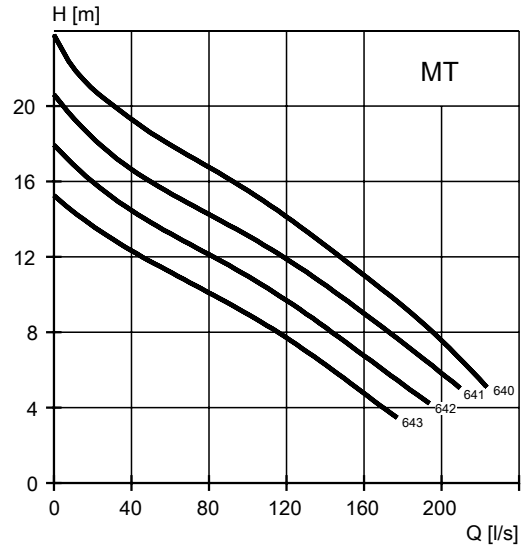
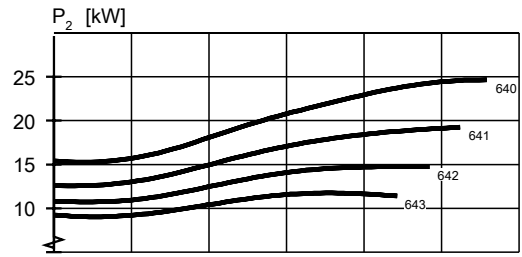
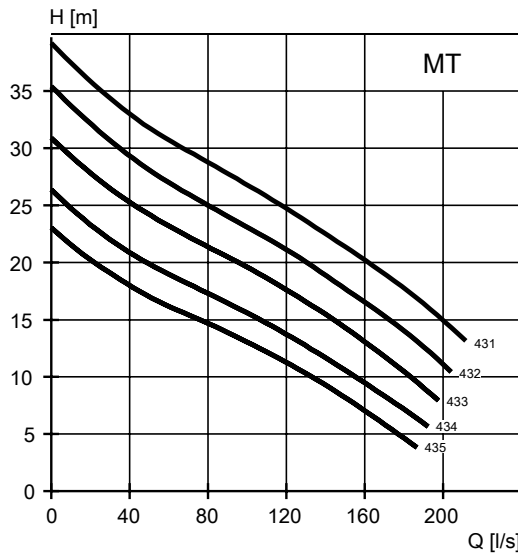
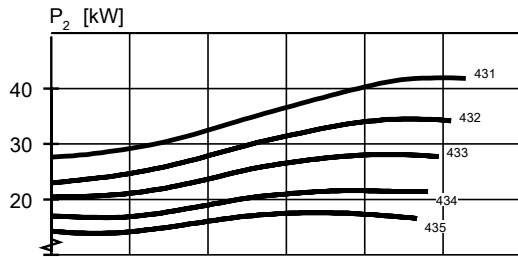

Table 25: 400 V, 50 Hz, 3-phase

Rated power, kW	Rated power, hp	Curve/ Impeller No	Revolutions per minute, rpm	Rated Current, A	Start current, A	Power factor, cos φ	Installation
23	31	640	980	45	270	0.79	P,S,T,Z
23	31	641	980	45	270	0.79	P,S,T,Z
23	31	642	980	45	270	0.79	P,S,T,Z
23	31	643	980	45	270	0.79	P,S,T,Z
30	40	433	1480	52	385	0.89	P,S,T,Z
30	40	434	1480	52	385	0.89	P,S,T,Z
30	40	435	1480	52	385	0.89	P,S,T,Z

Rated power, kW	Rated power, hp	Curve/ Impeller No	Revolutions per minute, rpm	Rated Current, A	Start current, A	Power factor, cos φ	Installation
31	42	640	980	60	360	0.81	P,S,T,Z
31	42	641	980	60	360	0.81	P,S,T,Z
31	42	642	980	60	360	0.81	P,S,T,Z
31	42	643	980	60	360	0.81	P,S,T,Z
37	50	432	1485	65	535	0.87	P,S,T,Z
37	50	433	1485	65	535	0.87	P,S,T,Z
37	50	434	1485	65	535	0.87	P,S,T,Z
37	50	435	1485	65	535	0.87	P,S,T,Z
38	51	640	980	77	495	0.77	P,S,T,Z
38	51	641	980	77	495	0.77	P,S,T,Z
38	51	642	980	77	495	0.77	P,S,T,Z
38	51	643	980	77	495	0.77	P,S,T,Z
45	60	431	1480	81	585	0.85	P,S,T,Z
45	60	432	1480	81	585	0.85	P,S,T,Z
45	60	433	1480	81	585	0.85	P,S,T,Z
45	60	434	1480	81	585	0.85	P,S,T,Z
45	60	435	1480	81	585	0.85	P,S,T,Z

HT

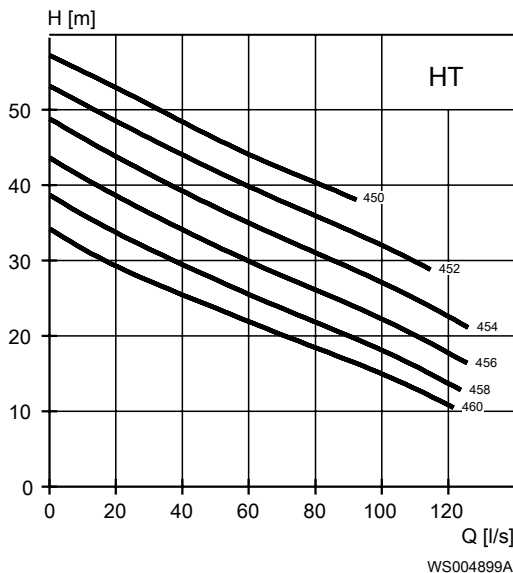
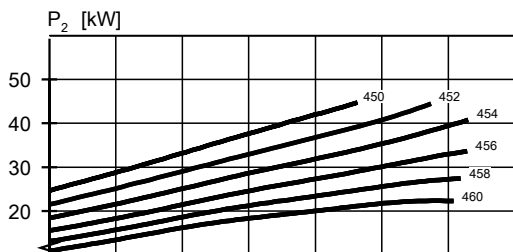



Table 26: 400 V, 50 Hz, 3-phase

Rated power, kW	Rated power, hp	Curve/ Impeller No	Revolutions per minute, rpm	Rated Current, A	Start current, A	Power factor, cos φ	Installation
30	40	454	1480	52	385	0.89	P,S,T,Z
30	40	456	1480	52	385	0.89	P,S,T,Z
30	40	458	1480	52	385	0.89	P,S,T,Z
30	40	460	1480	52	385	0.89	P,S,T,Z
37	50	450	1485	65	535	0.87	P,S,T,Z
37	50	452	1485	65	535	0.87	P,S,T,Z
37	50	454	1485	65	535	0.87	P,S,T,Z
37	50	456	1485	65	535	0.87	P,S,T,Z
37	50	458	1485	65	535	0.87	P,S,T,Z
37	50	460	1485	65	535	0.87	P,S,T,Z
45	60	450	1480	81	585	0.85	P,S,T,Z
45	60	452	1480	81	585	0.85	P,S,T,Z
45	60	454	1480	81	585	0.85	P,S,T,Z
45	60	456	1480	81	585	0.85	P,S,T,Z
45	60	458	1480	81	585	0.85	P,S,T,Z
45	60	460	1480	81	585	0.85	P,S,T,Z

SH

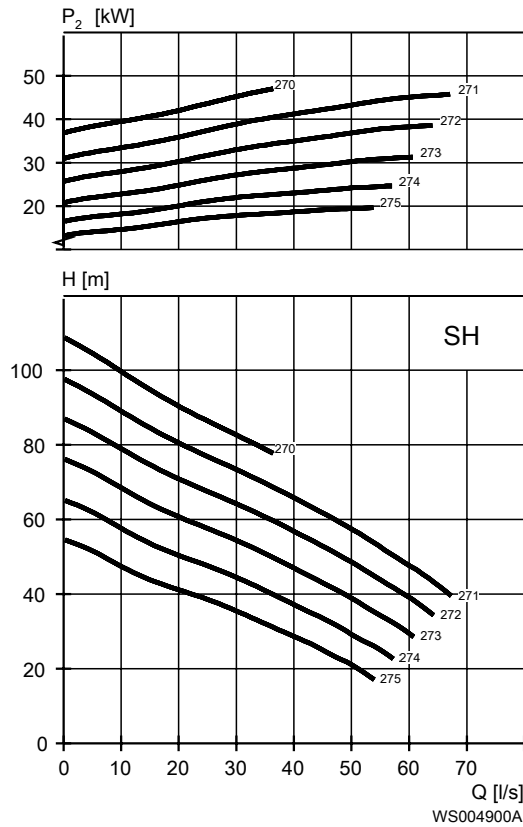

Table 27: 400 V, 50 Hz, 3-phase

Rated power, kW	Rated power, hp	Curve/ Impeller No	Revolutions per minute, rpm	Rated Current, A	Start current, A	Power factor, cos φ	Installation
47	63	270	2960	82	660	0.88	P,S,T,Z
47	63	271	2960	82	660	0.88	P,S,T,Z
47	63	272	2960	82	660	0.88	P,S,T,Z
47	63	273	2960	82	660	0.88	P,S,T,Z
47	63	274	2960	82	660	0.88	P,S,T,Z
47	63	275	2960	82	660	0.88	P,S,T,Z

## Motor rating and performance curves 3202.860/.870

These are examples of motor rating and curves. For more information, please contact your local sales and service representative.

Star-delta starting current is 1/3 of Direct on-line starting current.

MT

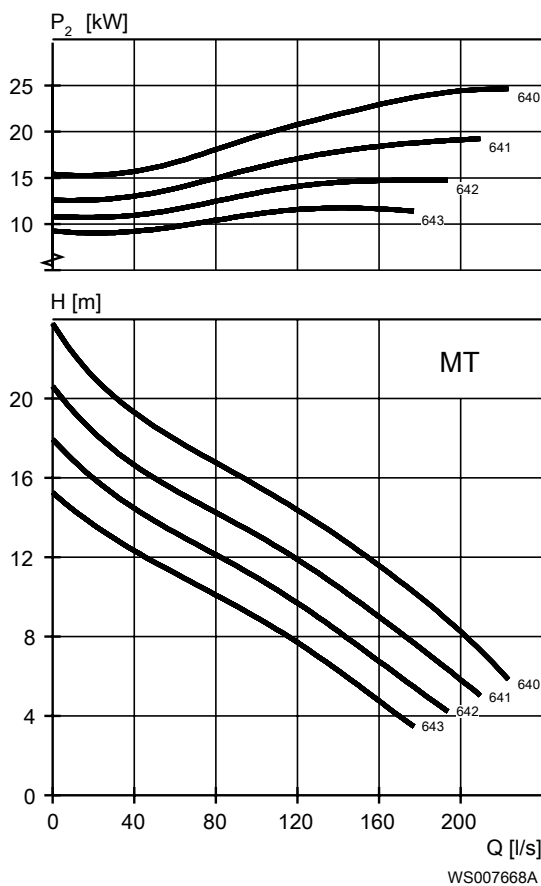

Table 28: 400 V, 50 Hz, 3-phase

Rated power, kW	Rated power, hp	Curve/ Impeller No	Revolutions per minute, rpm	Rated Current, A	Start current, A	Power Factor, cos φ	Installation
23	31	641	980	45	270	0.79	P,S
23	31	642	980	45	270	0.79	P,S
23	31	643	980	45	270	0.79	P,S

Rated power, kW	Rated power, hp	Curve/ Impeller No	Revolutions per minute, rpm	Rated Current, A	Start current, A	Power Factor, cos φ	Installation
31	42	640	980	60	360	0.81	P,S
31	42	641	980	60	360	0.81	P,S
31	42	642	980	60	360	0.81	P,S
31	42	643	980	60	360	0.81	P,S
38	51	640	980	77	495	0.77	P,S
38	51	641	980	77	495	0.77	P,S
38	51	642	980	77	495	0.77	P,S
38	51	643	980	77	495	0.77	P,S

HT

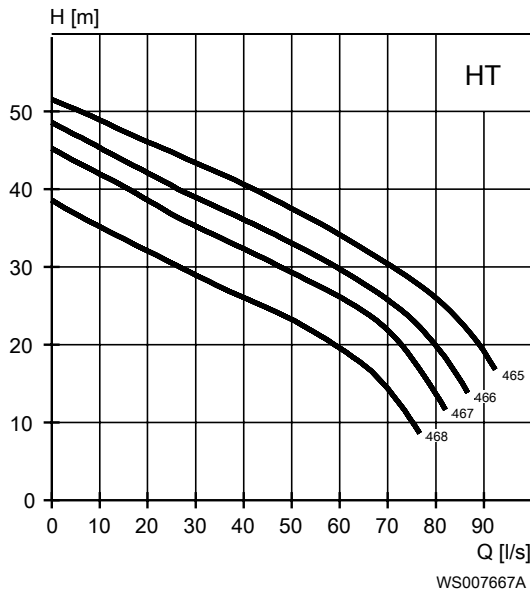

Table 29: 400 V, 50 Hz, 3-phase

Rated power, kW	Rated power, hp	Curve/ Impeller No	Revolutions per minute, rpm	Rated Current, A	Start current, A	Power Factor, cos φ	Installation
30	40	466	1485	57	425	0.82	P,S
30	40	467	1485	57	425	0.82	P,S
30	40	468	1485	57	425	0.82	P,S
37	50	465	1485	73	540	0.78	P,S
37	50	466	1485	73	540	0.78	P,S
37	50	467	1485	73	540	0.78	P,S
37	50	468	1485	73	540	0.78	P,S

Rated power, kW	Rated power, hp	Curve/ Impeller No	Revolutions per minute, rpm	Rated Current, A	Start current, A	Power Factor, cos $\phi$	Installation
45	60	465	1480	81	585	0.85	P,S
45	60	466	1480	81	585	0.85	P,S
45	60	467	1480	81	585	0.85	P,S
45	60	468	1480	81	585	0.85	P,S

# Dimensions and Weight, Standard Motor

## Drawings

All drawings are available as Acrobat documents (.pdf) and AutoCad drawings (.dwg). Contact your local sales and service representative for more information. All dimensions are in mm.

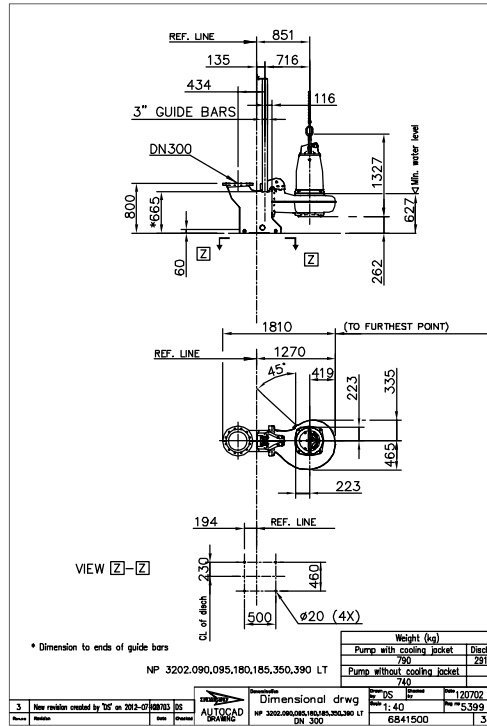

Figure 1: LT, P-installation

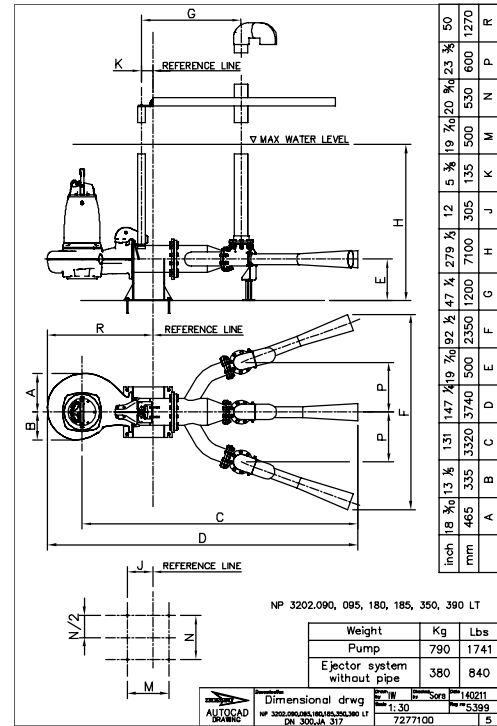

Figure 2: LT, P-installation

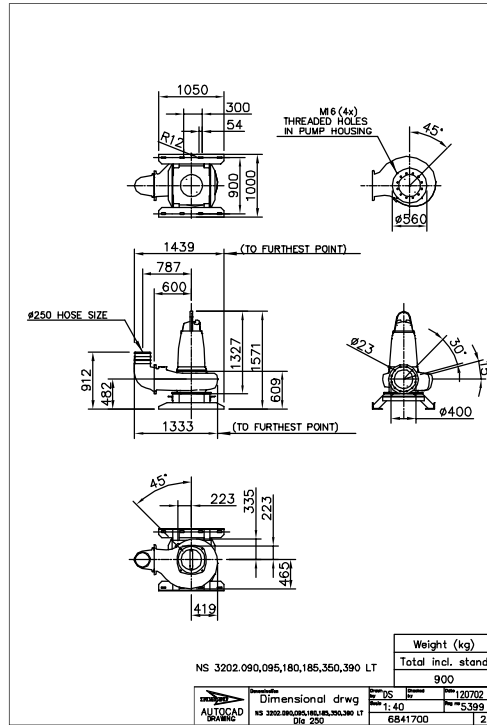

Figure 3: LT, S-installation

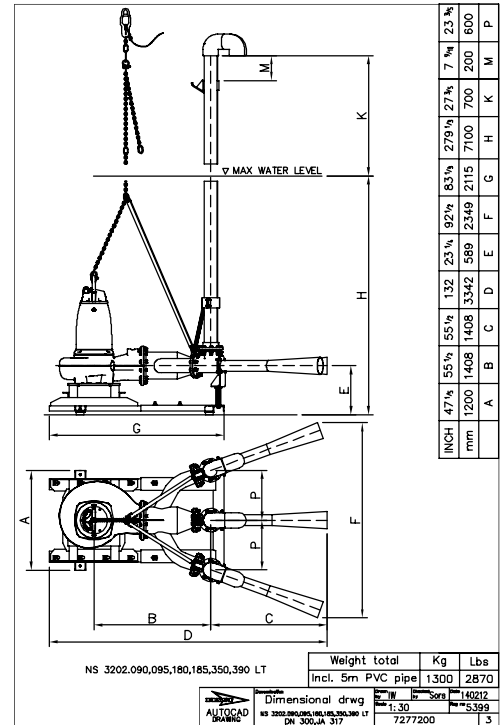

Figure 4: LT, S-installation

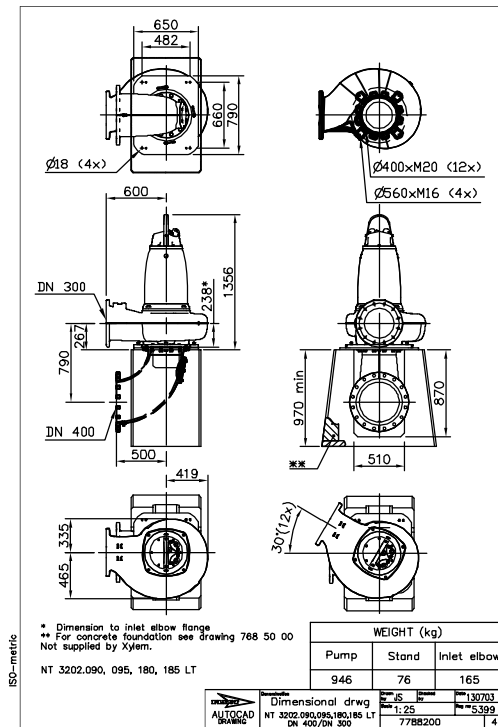

Figure 5: LT, T-installation

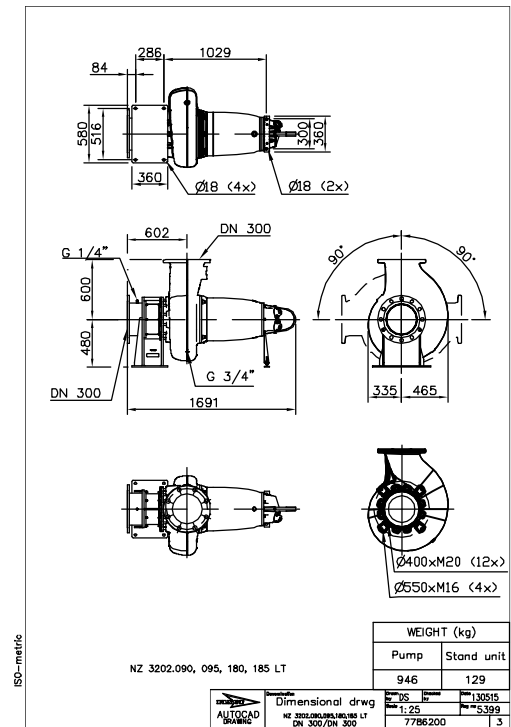

Figure 6: LT, Z-installation

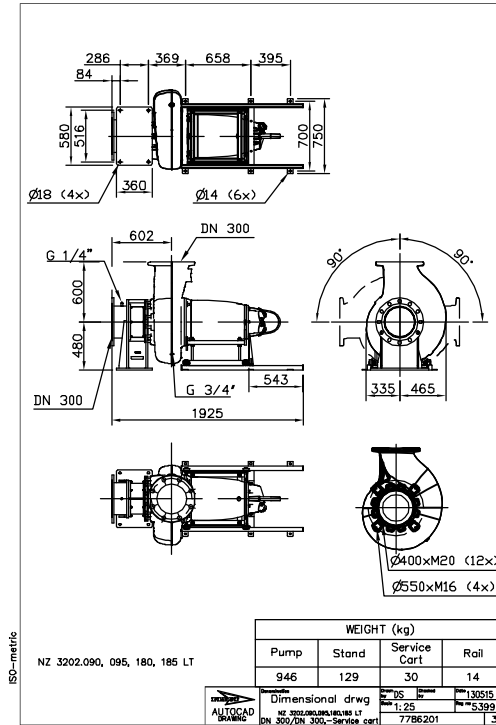

Figure 7: LT, Z-installation

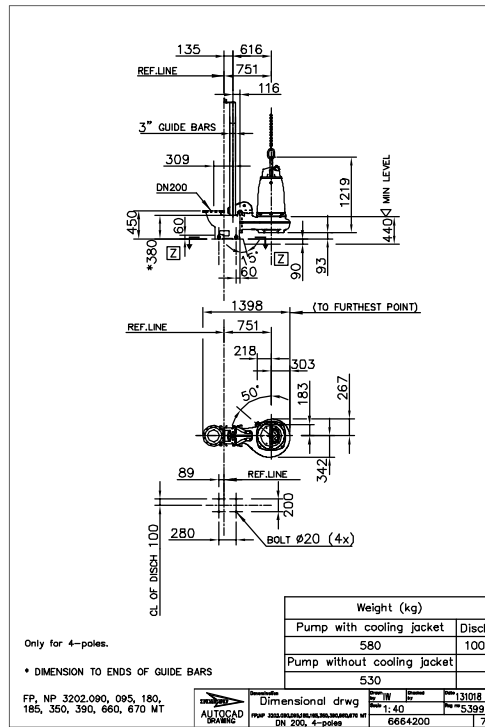

Figure 8: MT, P-installation

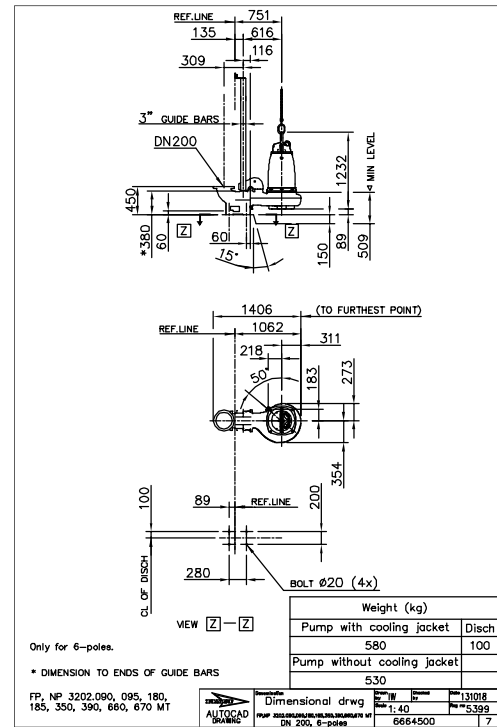

Figure 9: MT, P-installation

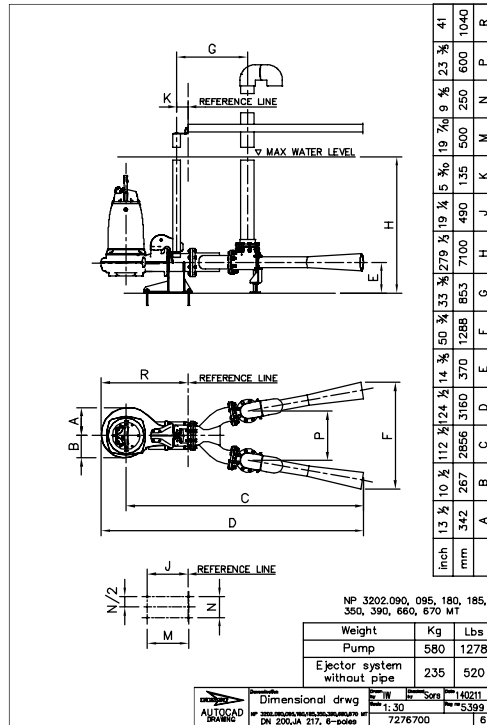

Figure 10: MT, P-installation

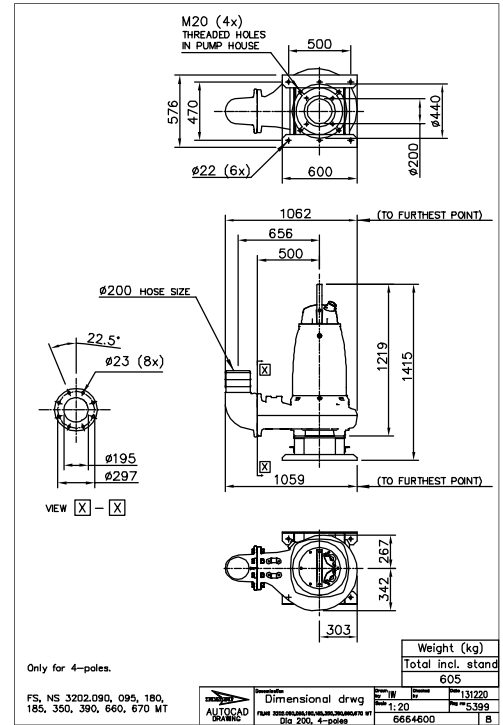

Figure 11: MT, S-installation

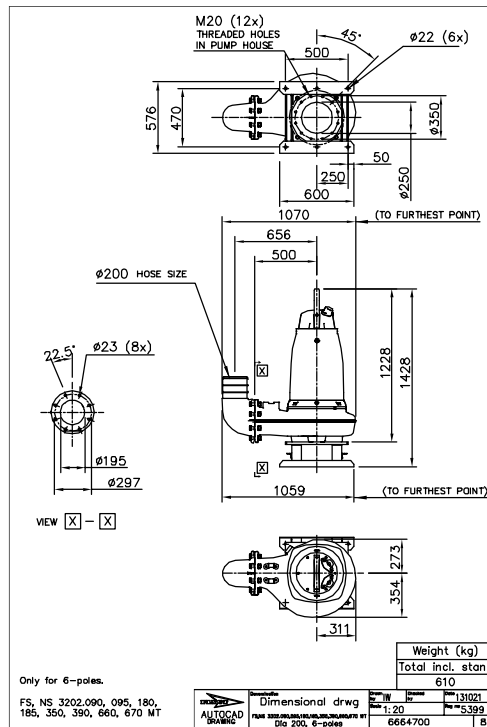

Figure 12: MT, S-installation

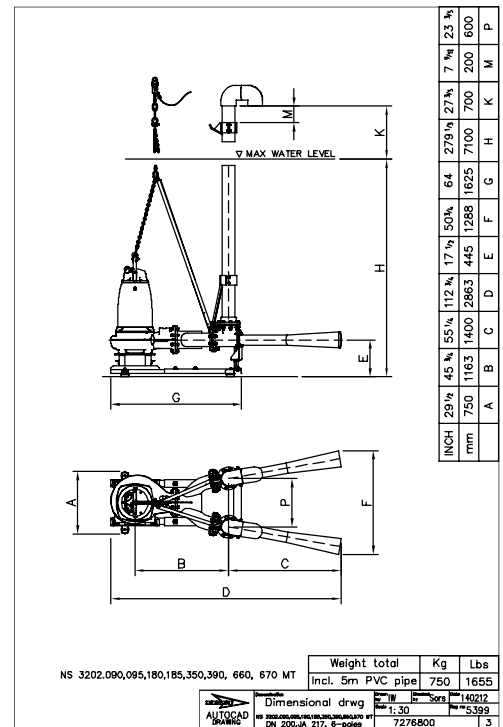

Figure 13: MT, S-installation



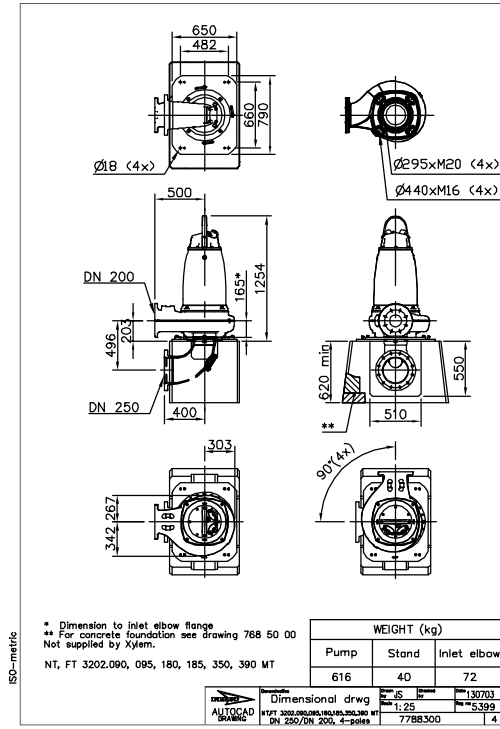

Figure 14: MT, T-installation

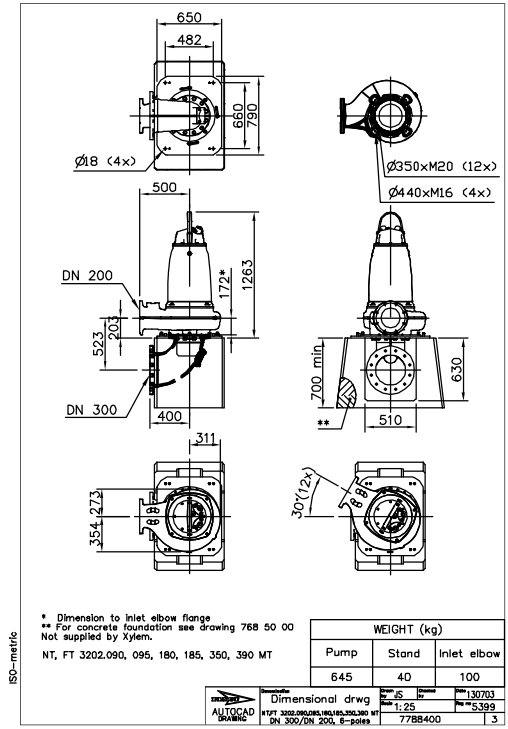

Figure 15: MT, T-installation

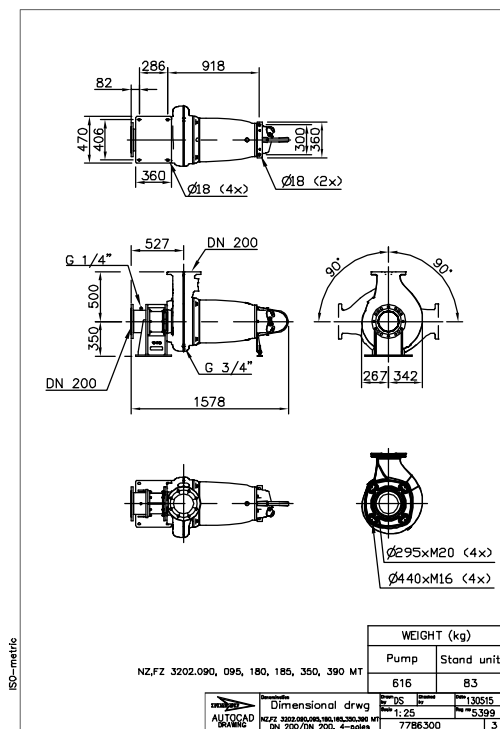

Figure 16: MT, Z-installation

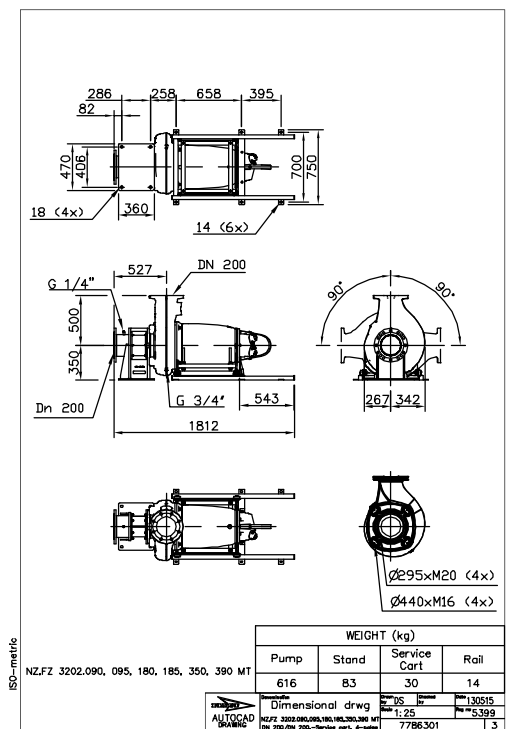

Figure 17: MT, Z-installation

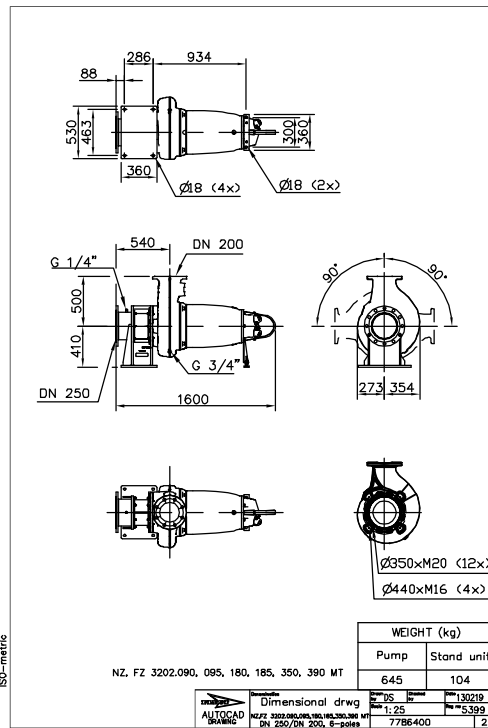

Figure 18: MT, Z-installation

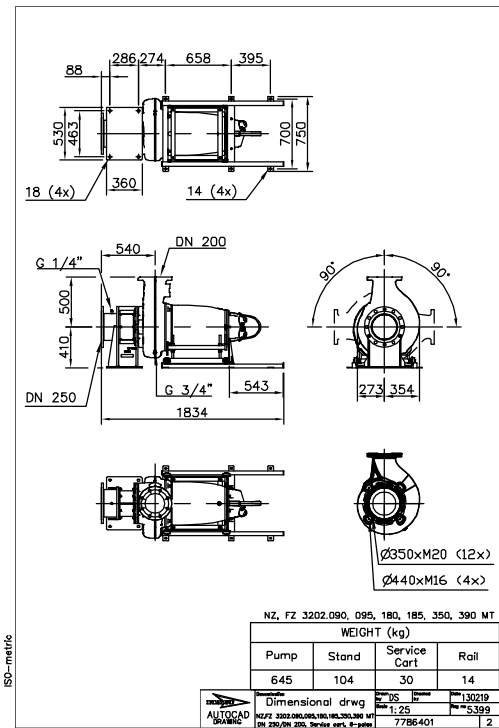

Figure 19: MT, Z-installation

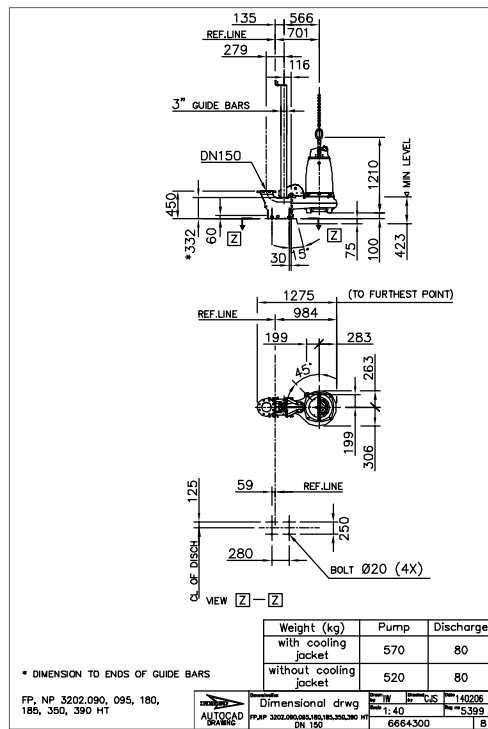

Figure 20: HT, P-installation

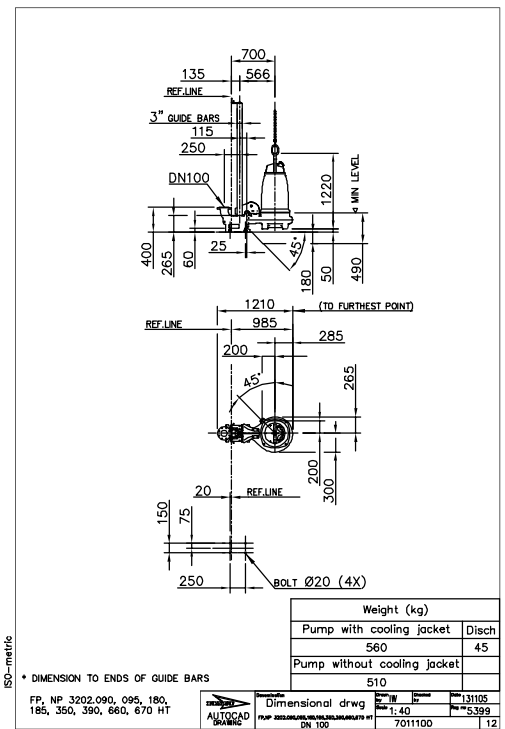

Figure 21: HT, P-installation

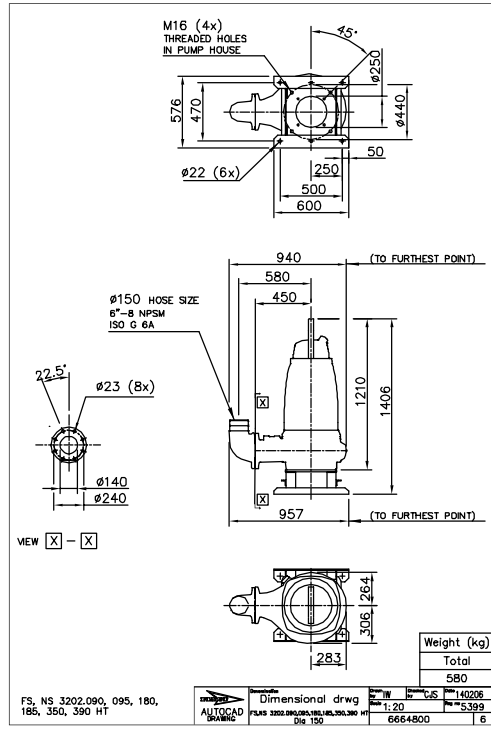

Figure 22: HT, S-installation

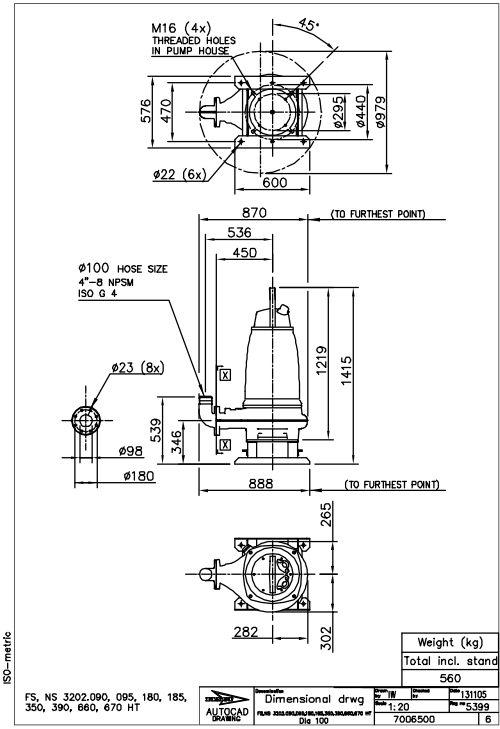

Figure 23: HT, S-installation

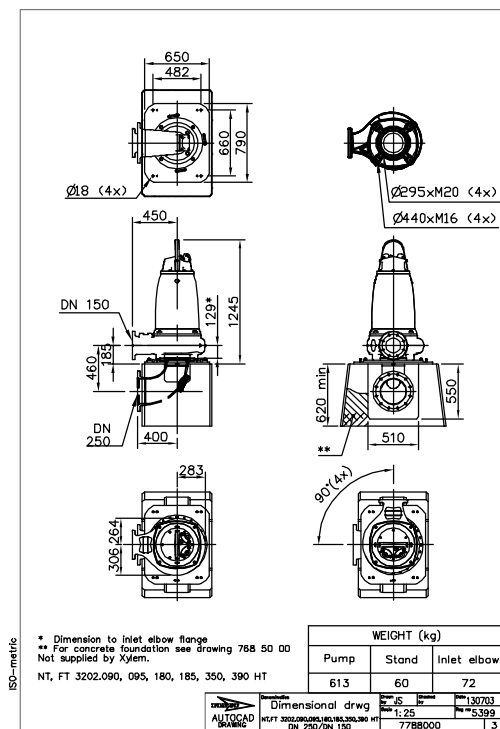

Figure 24: HT, T-installation

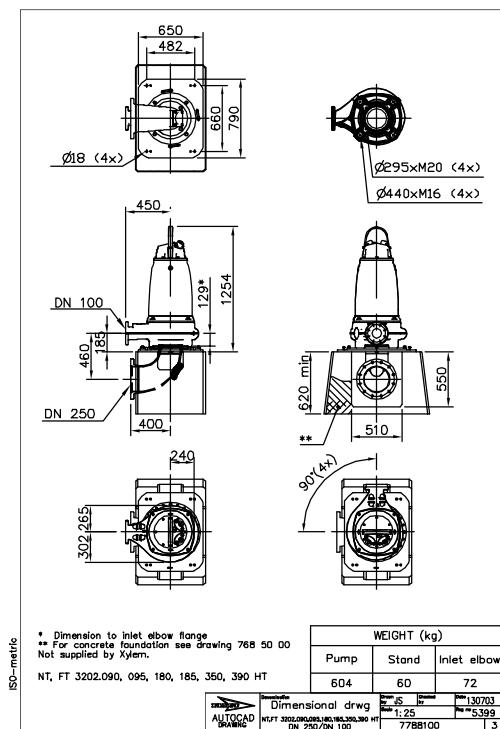

Figure 25: HT, T-installation

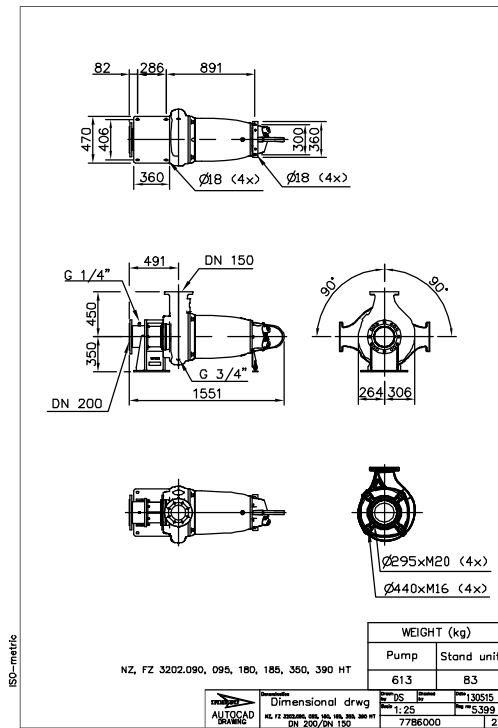

Figure 26: HT, Z-installation

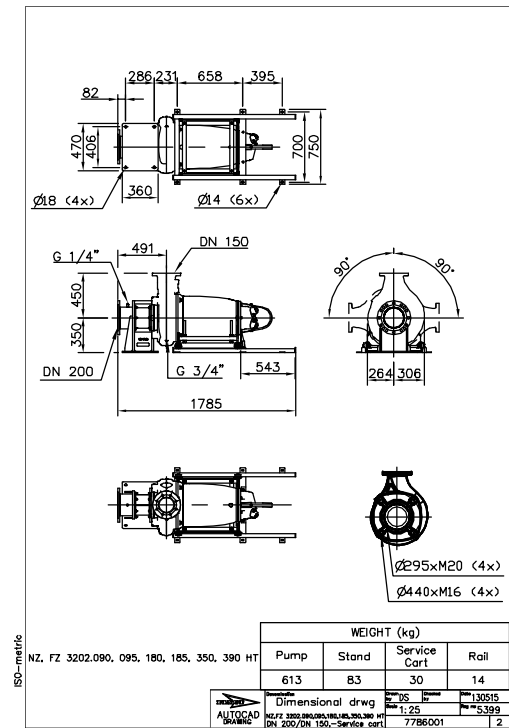

Figure 27: HT, Z-installation

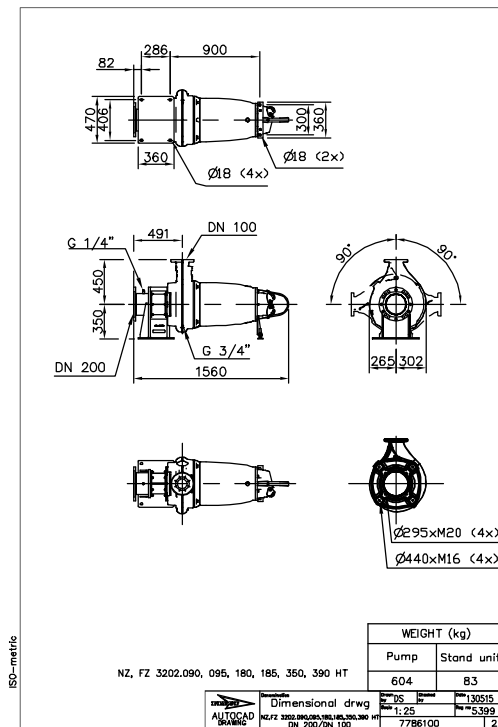

Figure 28: HT, Z-installation

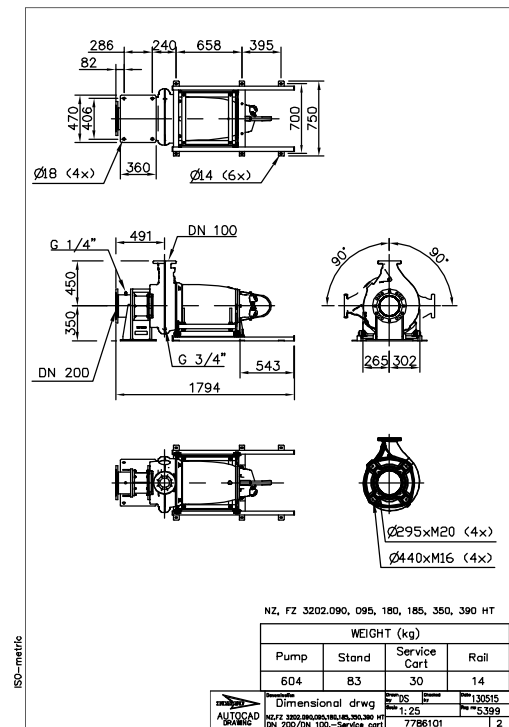

Figure 29: HT, Z-installation

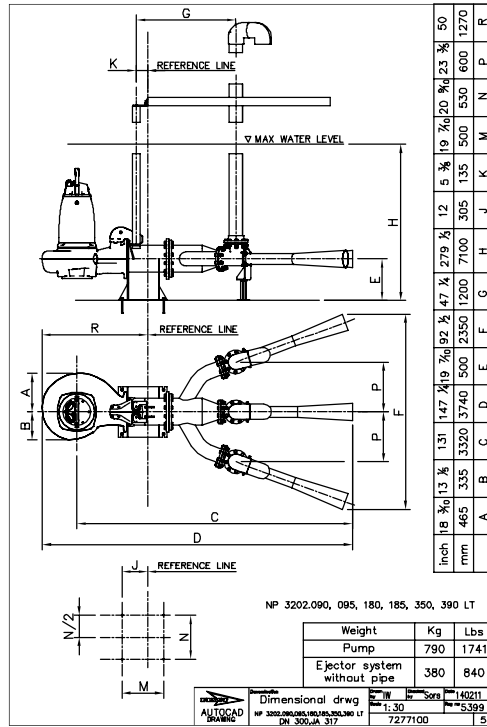

Figure 30: SH, P-installation

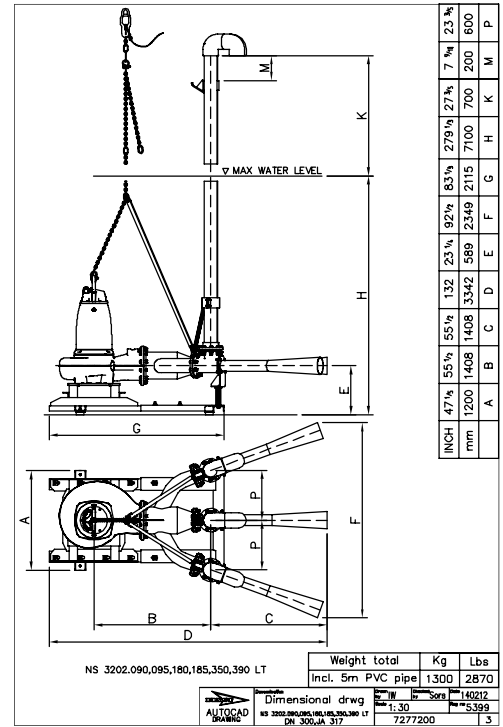

Figure 31: SH, S-installation

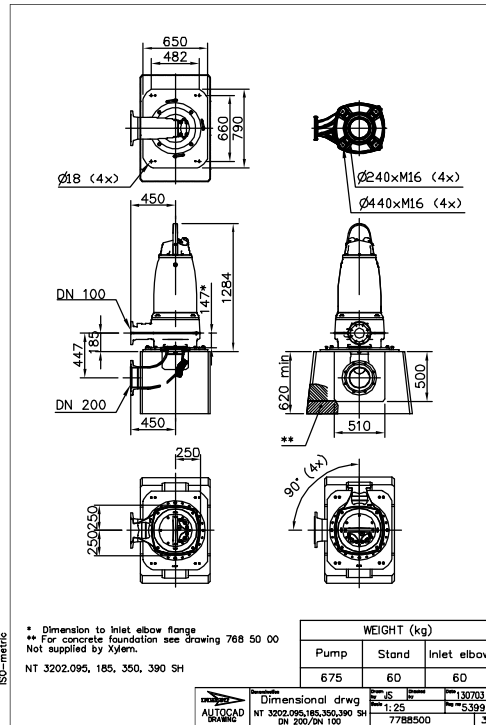

Figure 32: SH, T-installation

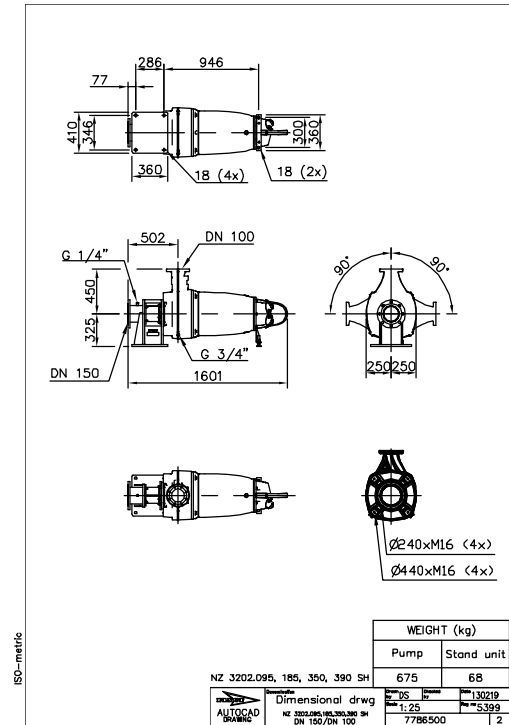

Figure 33: SH, Z-installation

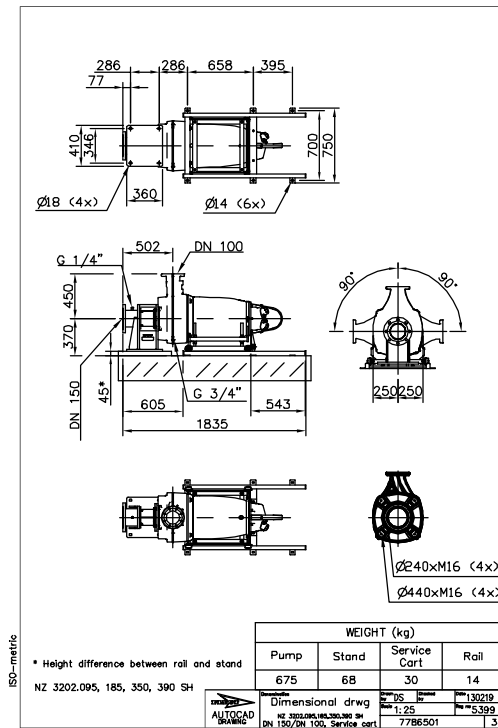

Figure 34: SH, Z-installation

# Dimensions and Weight, Standard Motor

## Drawings

All drawings are available as Acrobat documents (.pdf) and AutoCad drawings (.dwg). Contact your local sales and service representative for more information. All dimensions are in mm.

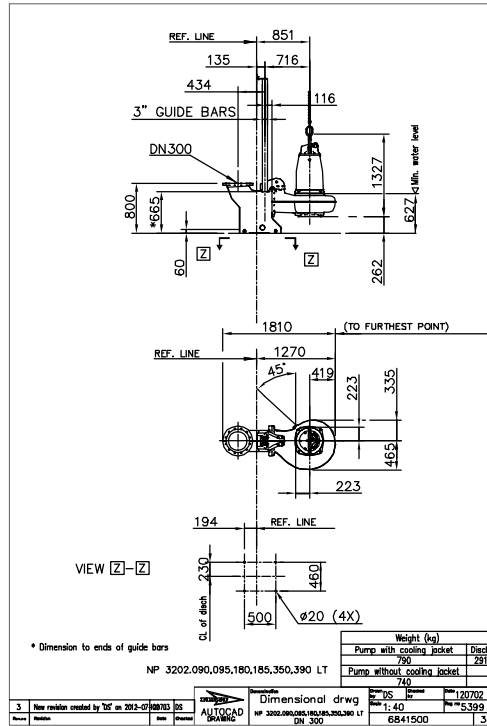

Figure 1: LT, P-installation

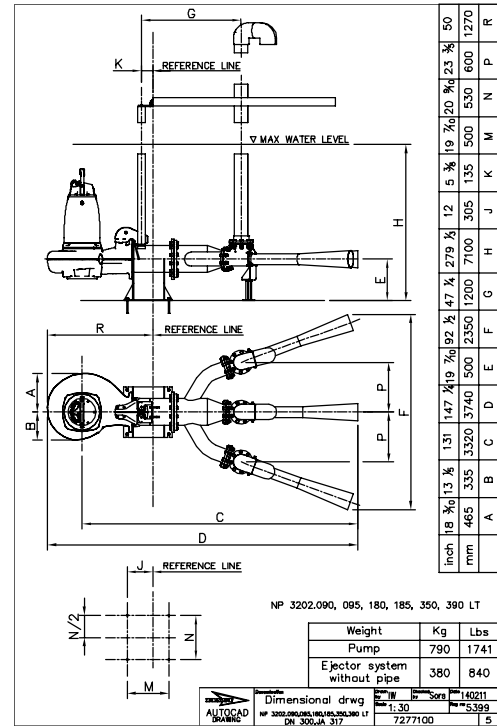

Figure 2: LT, P-installation

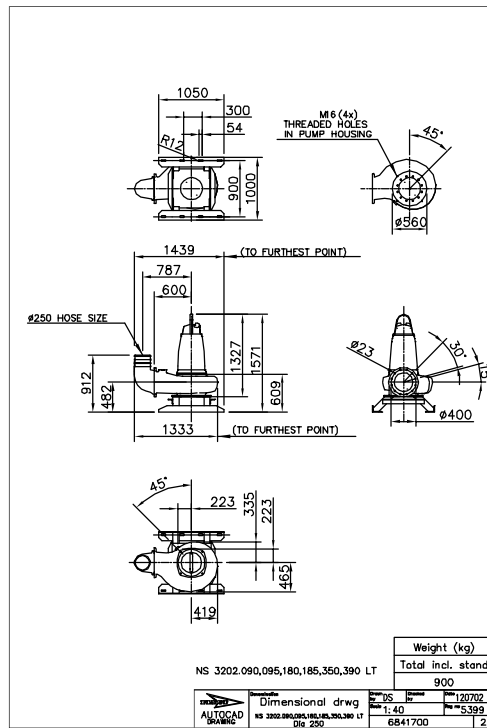

Figure 3: LT, S-installation

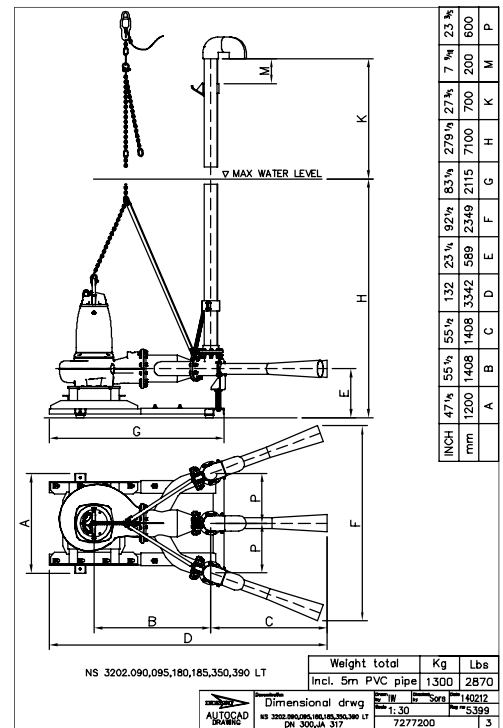

Figure 4: LT, S-installation

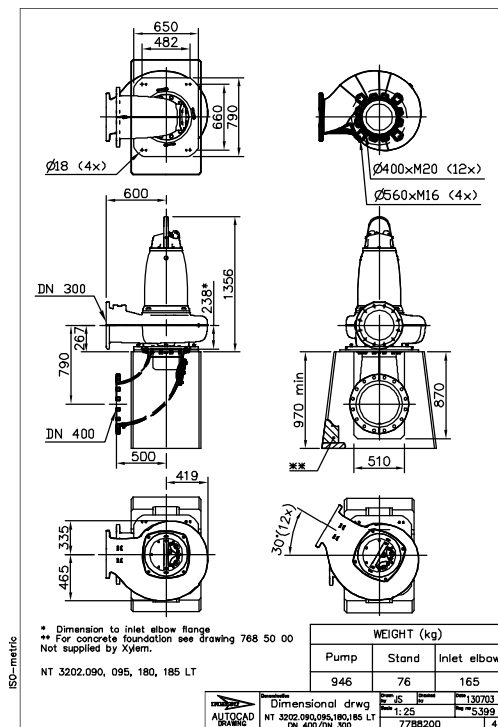

Figure 5: LT, T-installation

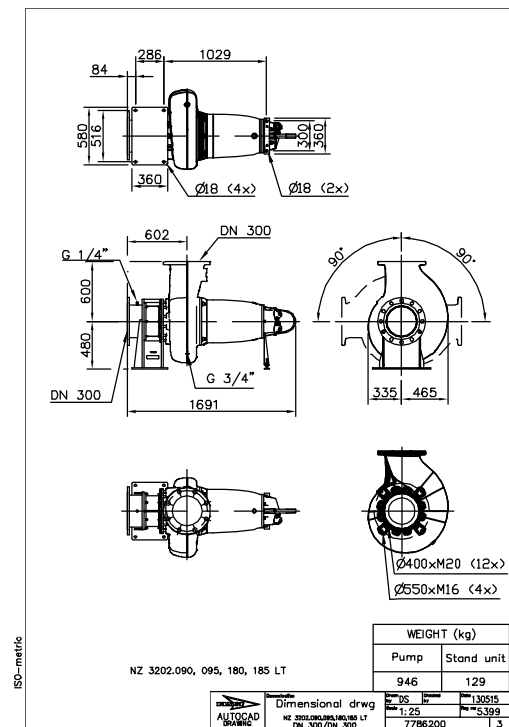

Figure 6: LT, Z-installation



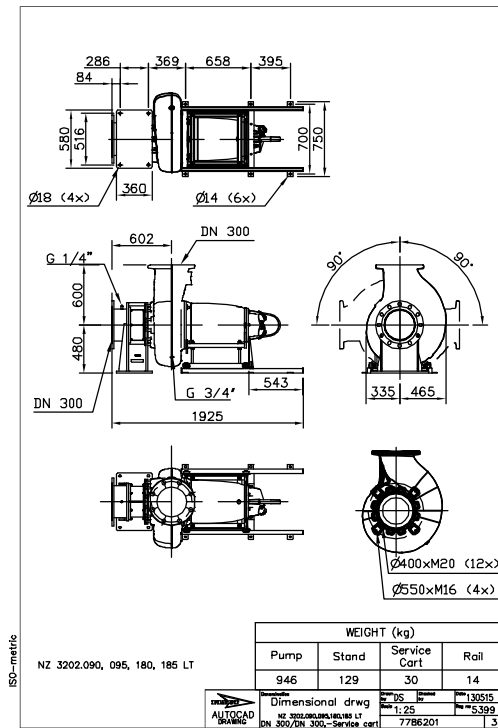

Figure 7: LT, Z-installation

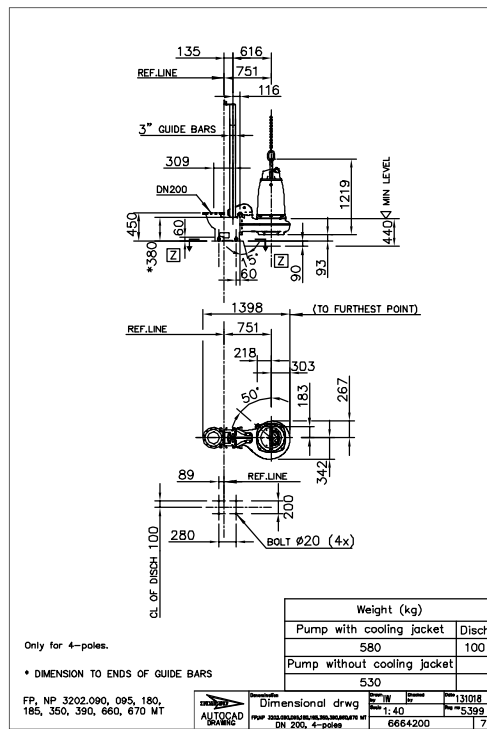

Figure 8: MT, P-installation

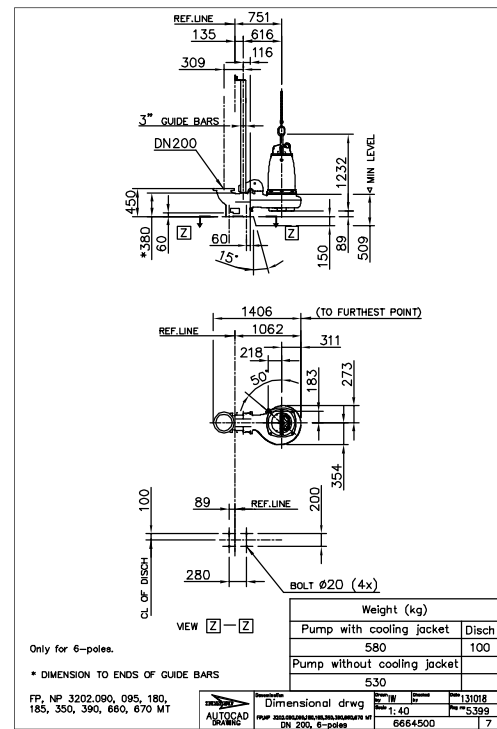

Figure 9: MT, P-installation

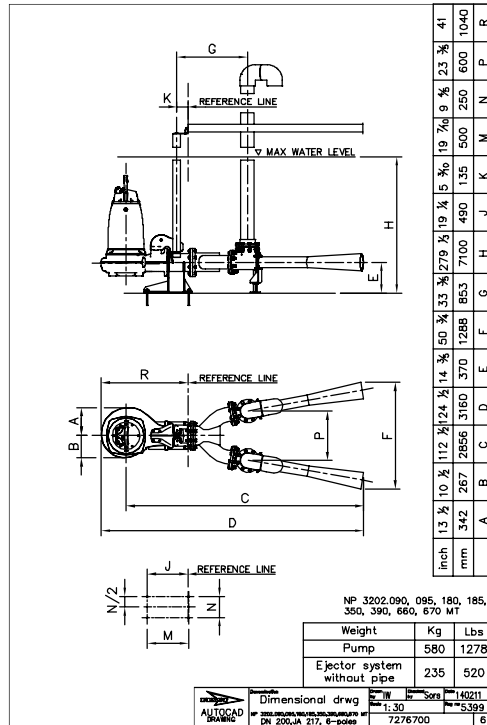

Figure 10: MT, P-installation

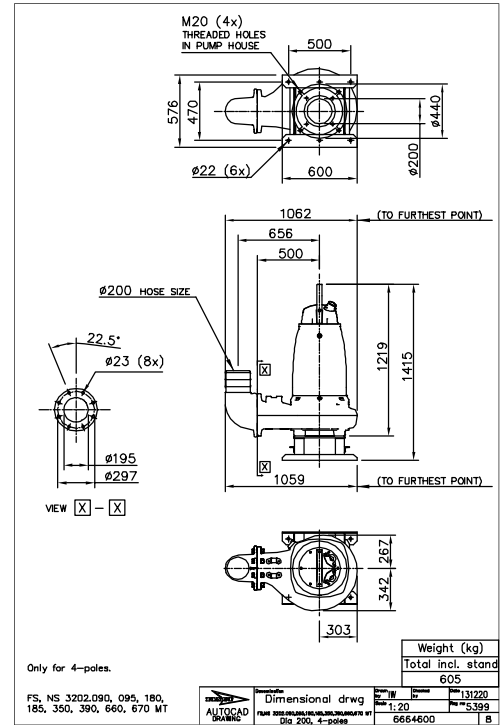

Figure 11: MT, S-installation

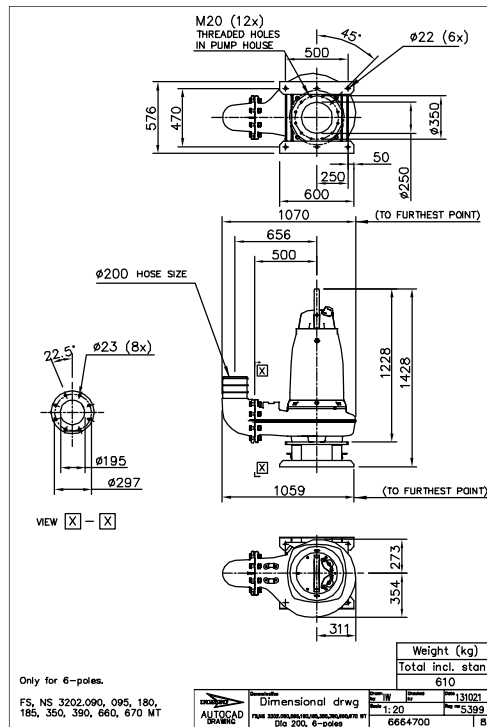

Figure 12: MT, S-installation

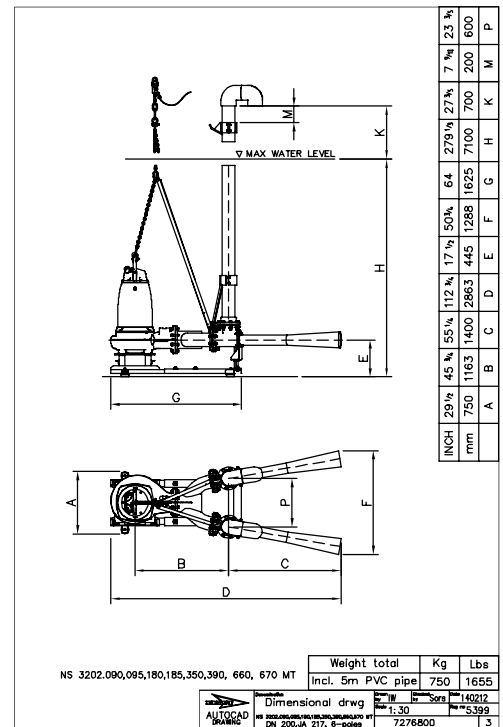

Figure 13: MT, S-installation

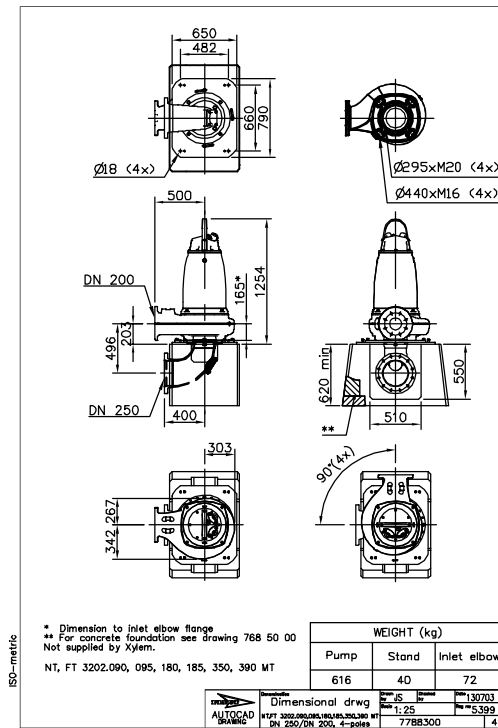

Figure 14: MT, T-installation

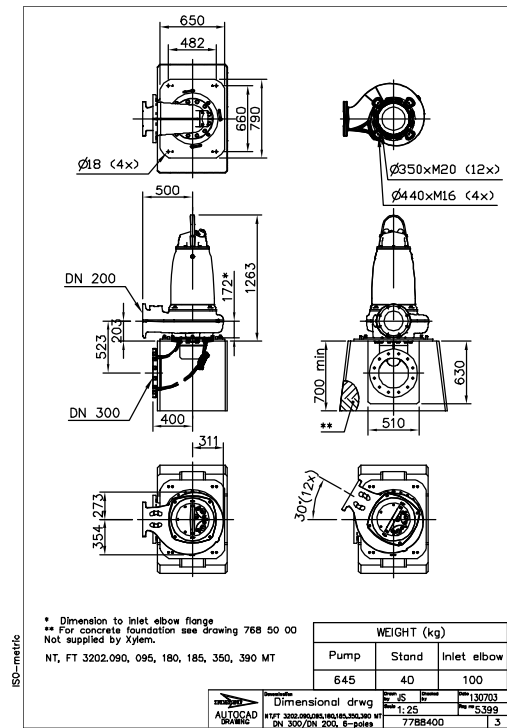

Figure 15: MT, T-installation

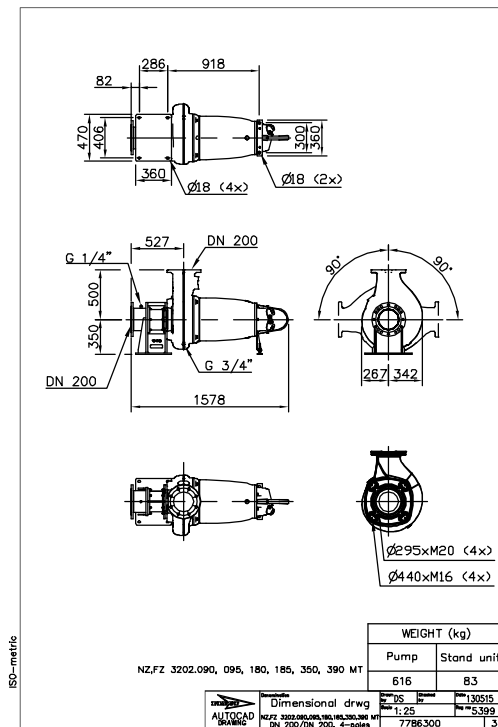

Figure 16: MT, Z-installation

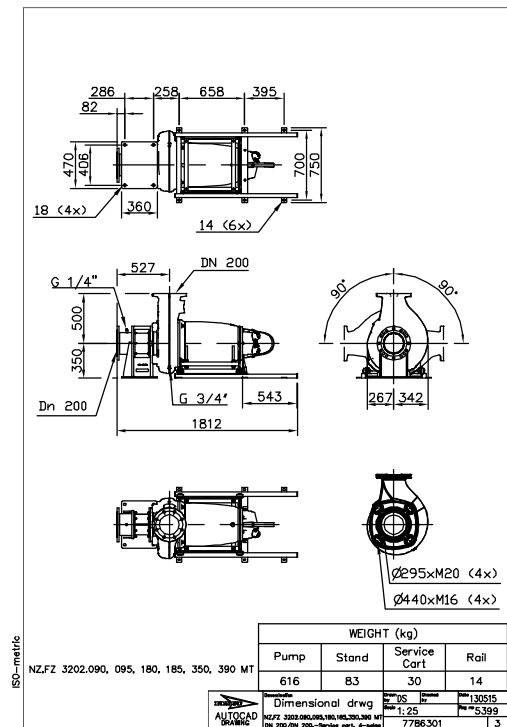

Figure 17: MT, Z-installation

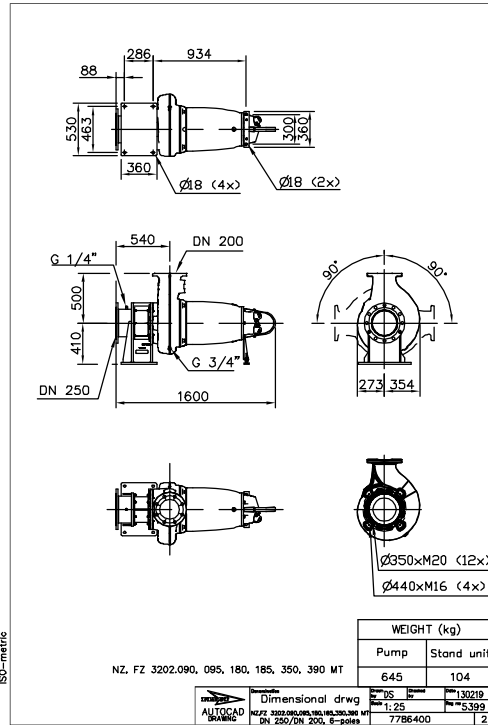

Figure 18: MT, Z-installation

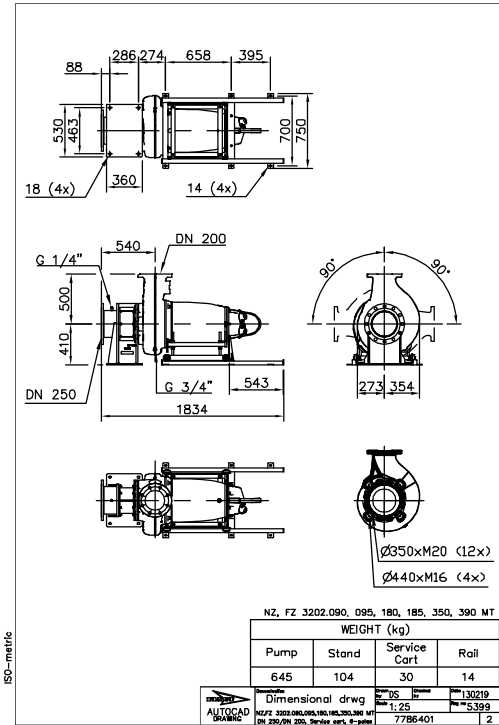

Figure 19: MT, Z-installation

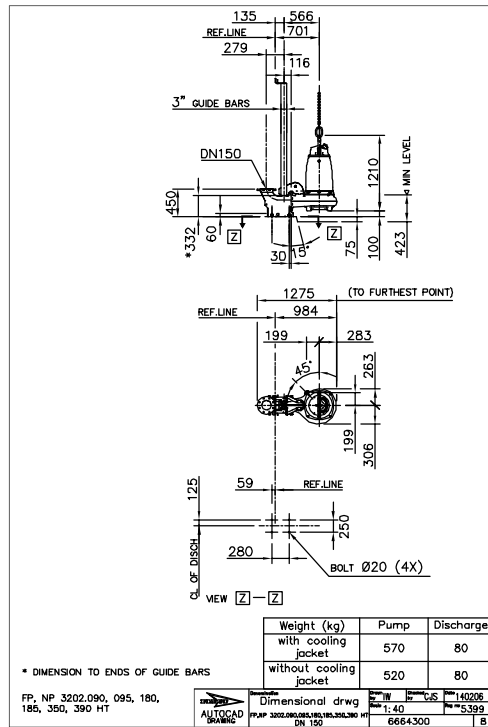

Figure 20: HT, P-installation

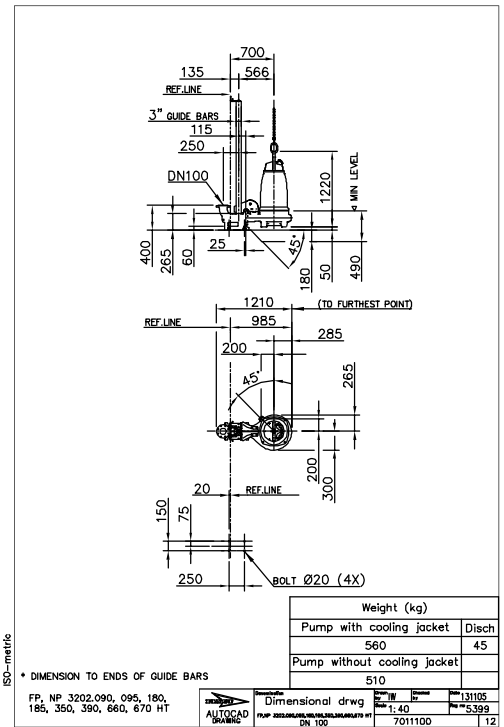

Figure 21: HT, P-installation

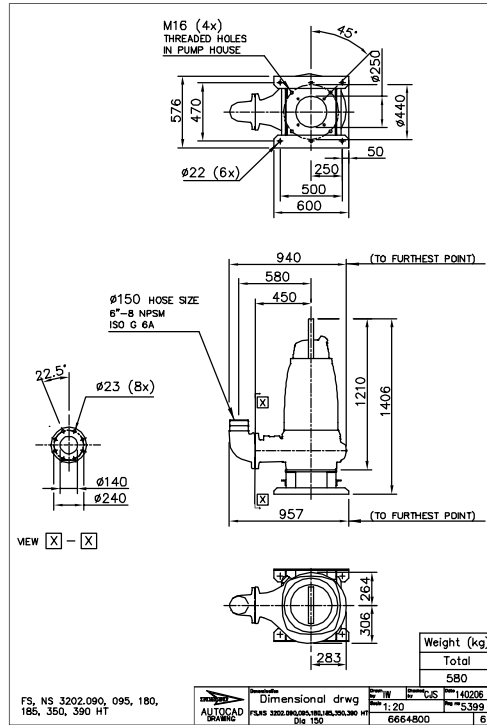

Figure 22: HT, S-installation

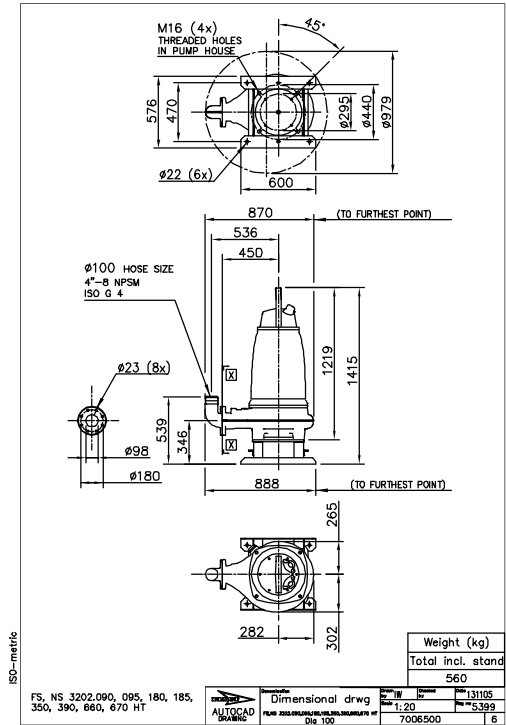

Figure 23: HT, S-installation

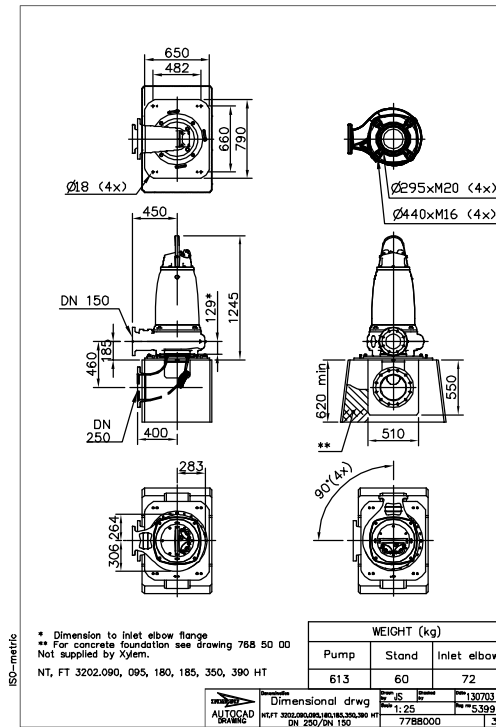

Figure 24: HT, T-installation

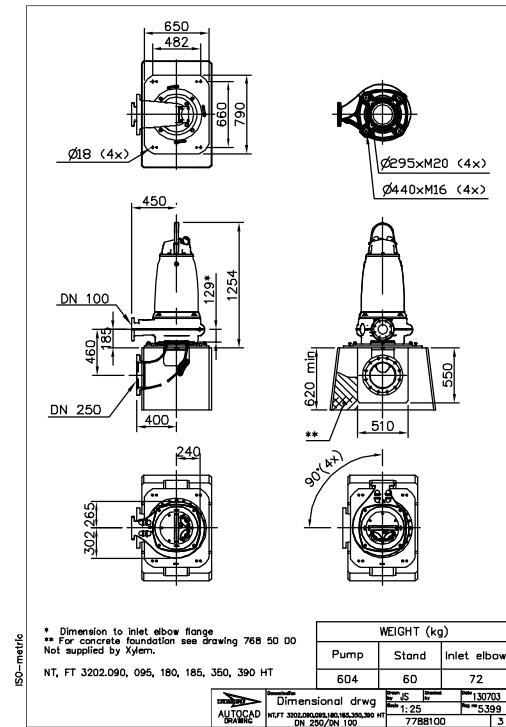

Figure 25: HT, T-installation

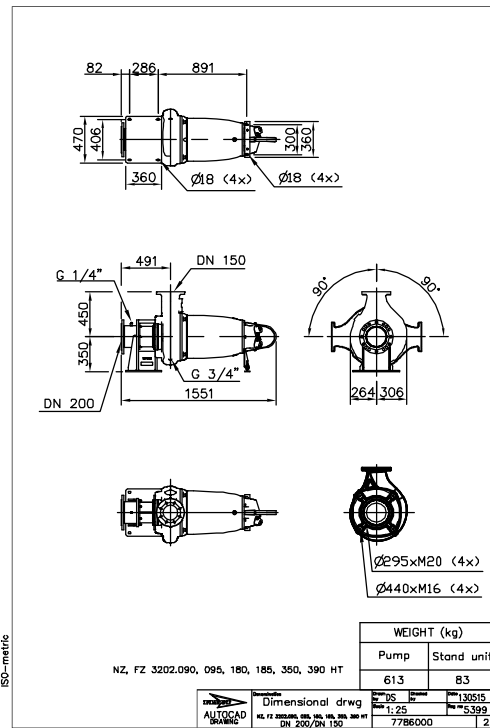

Figure 26: HT, Z-installation

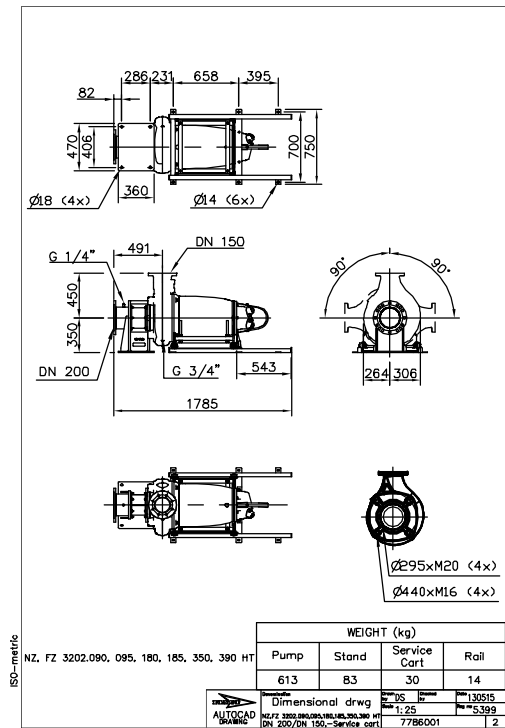

Figure 27: HT, Z-installation

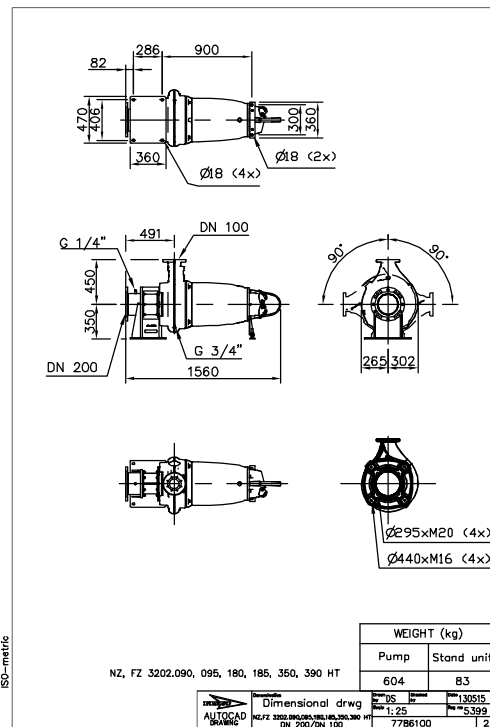

Figure 28: HT, Z-installation

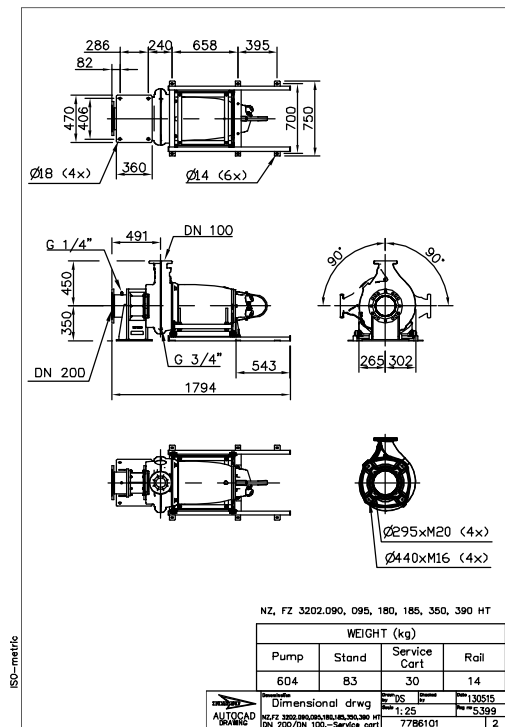

Figure 29: HT, Z-installation

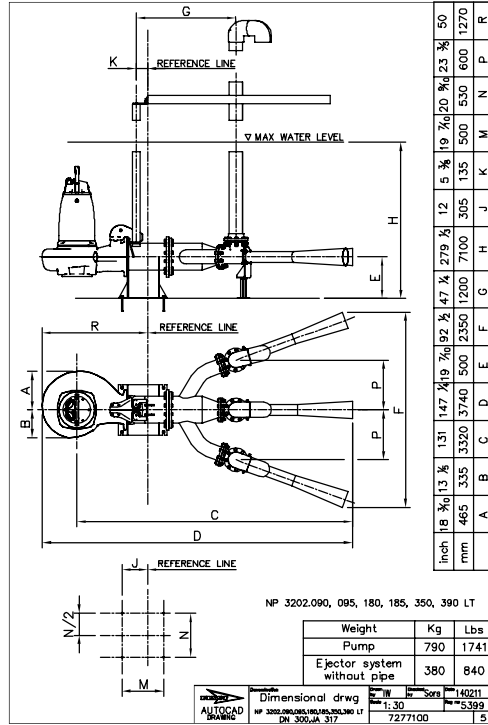

Figure 30: SH, P-installation

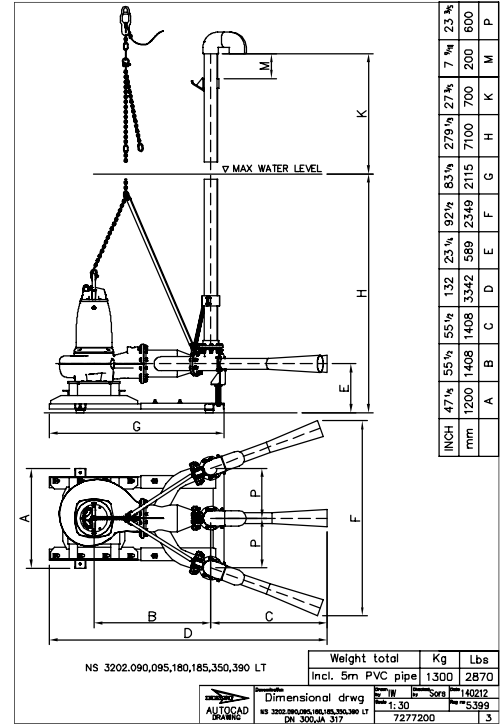

Figure 31: SH, S-installation

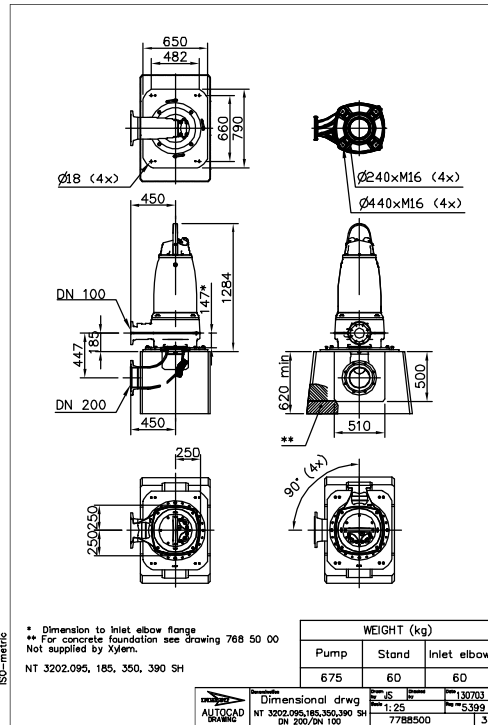

Figure 32: SH, T-installation

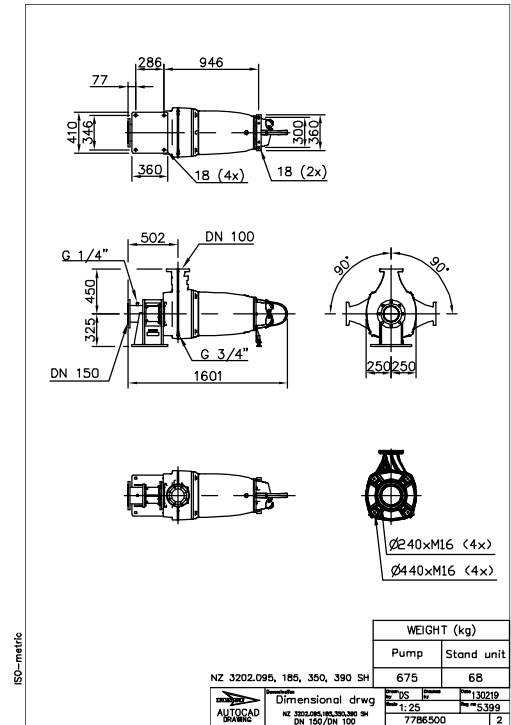

Figure 33: SH, Z-installation

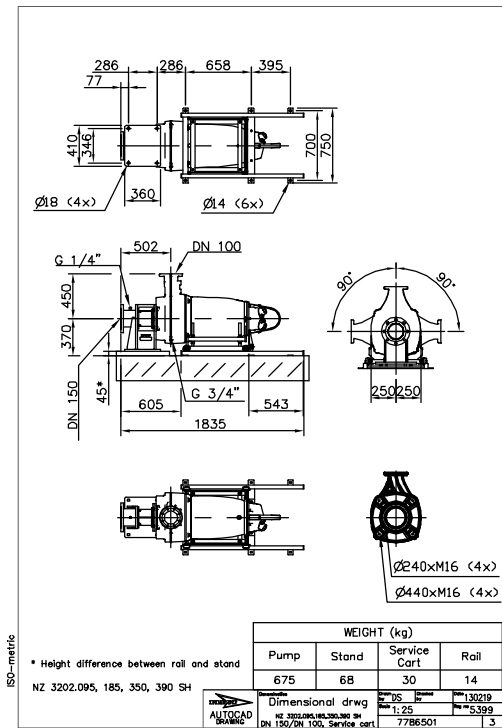

Figure 34: SH, Z-installation



# Dimensions and Weight, Premium Efficiency Motor (IE3)

## Drawings

All drawings are available as Acrobat documents (.pdf) and AutoCad drawings (.dwg). Contact your local sales and service representative for more information.

All dimensions are in mm.

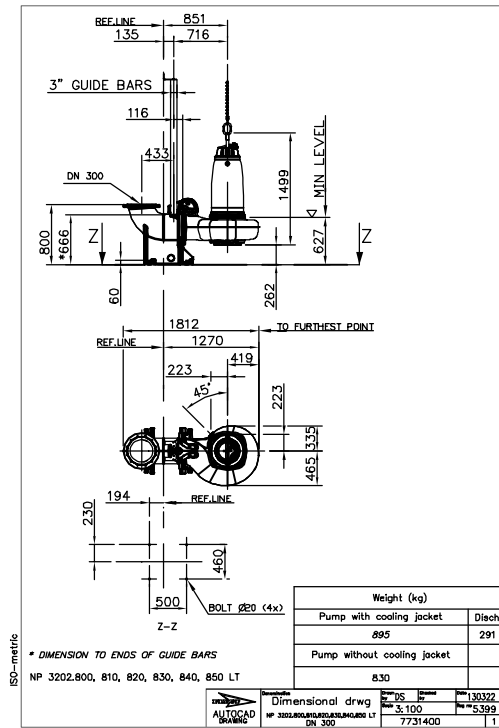

Figure 35: LT, P-installation

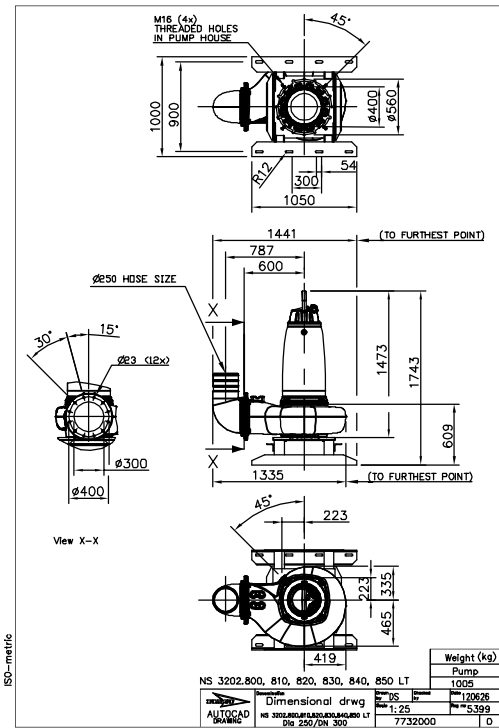

Figure 36: LT, S-installation

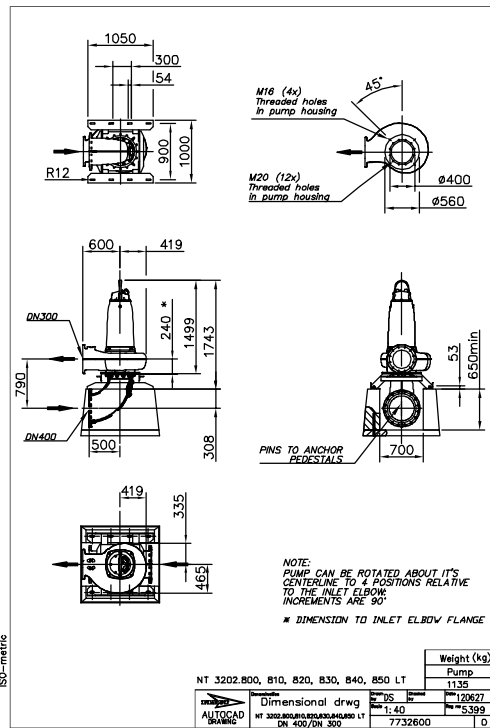

Figure 37: LT, T-installation

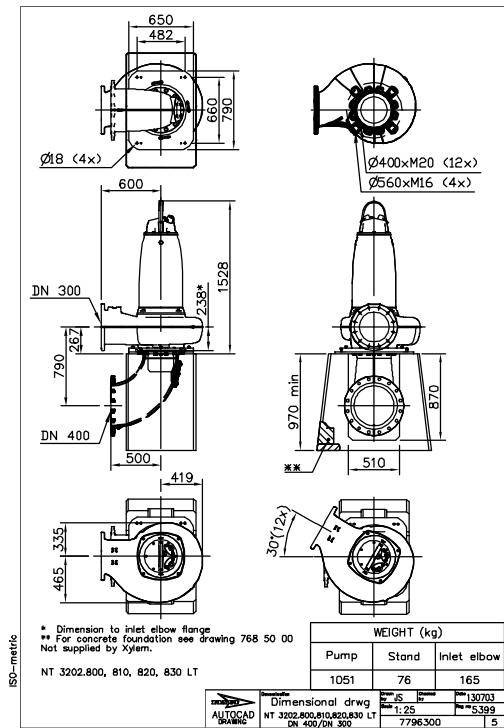

Figure 38: LT, T-installation

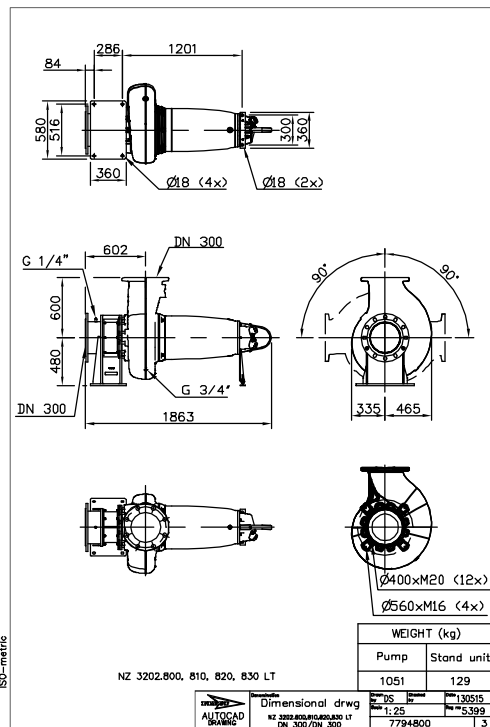

Figure 39: LT, Z-installation

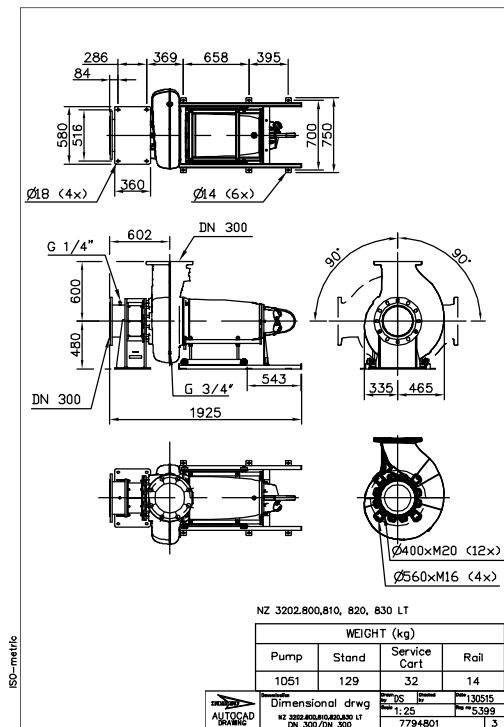

Figure 40: LT, Z-installation

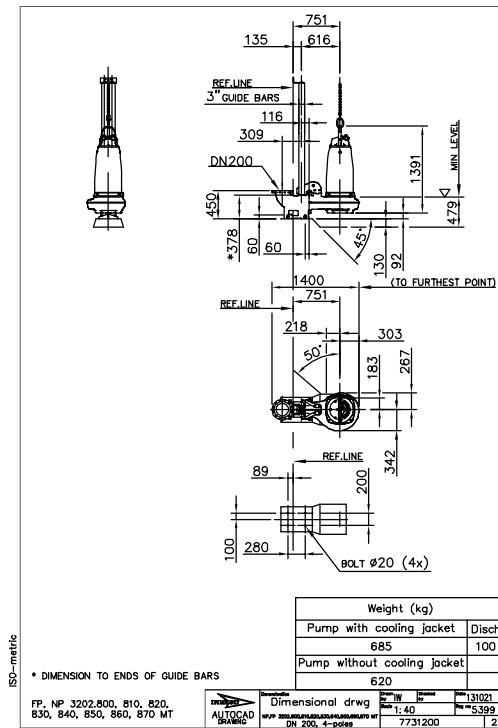

Figure 41: MT, P-installation

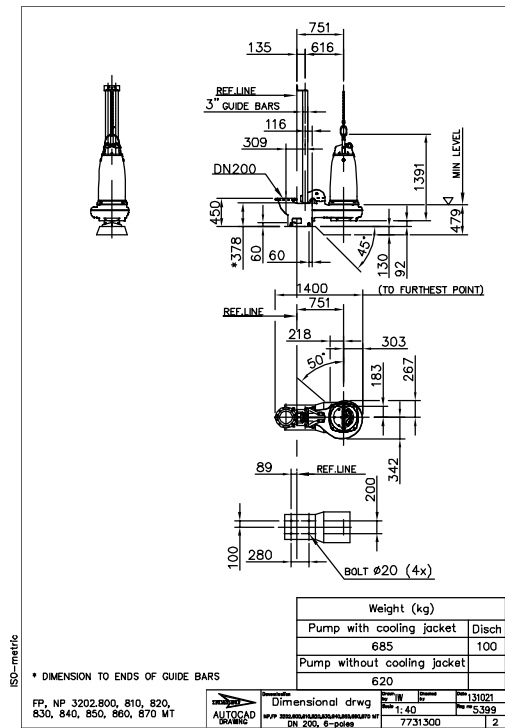

Figure 42: MT, P-installation

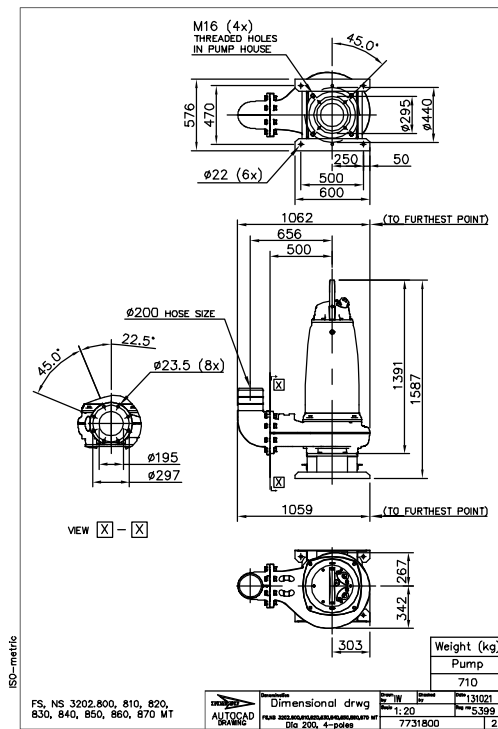

Figure 43: MT, S-installation

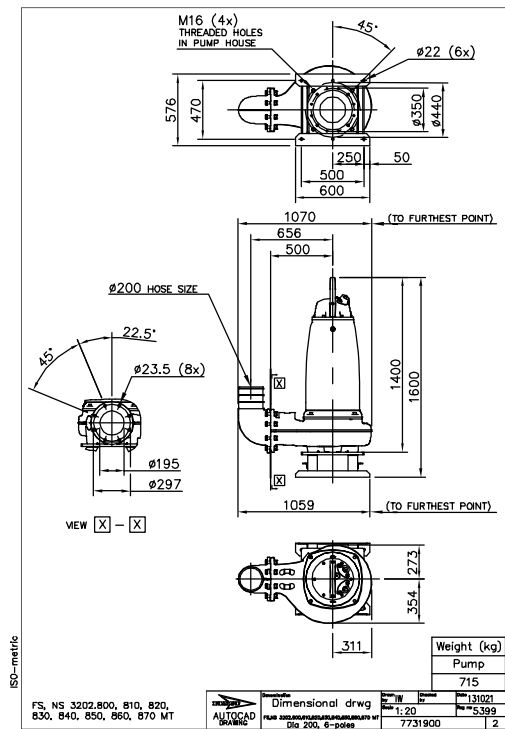

Figure 44: MT, S-installation

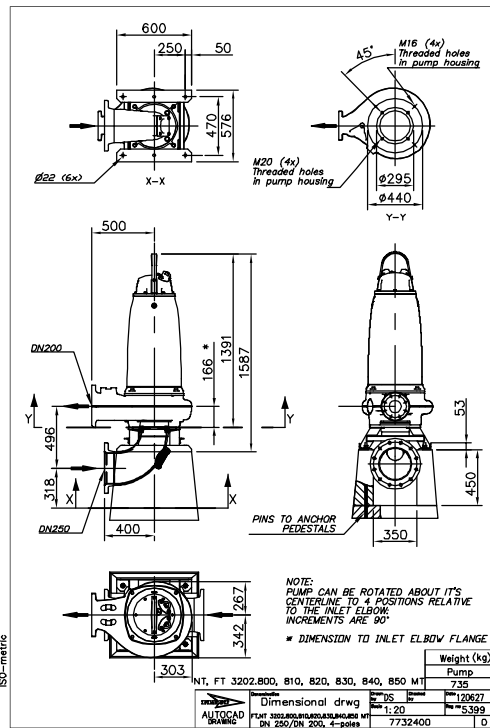

Figure 45: MT, T-installation

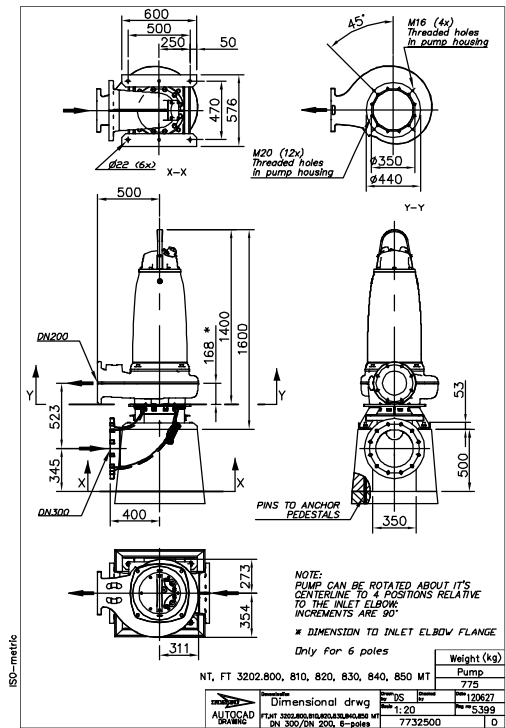

Figure 46: MT, T-installation

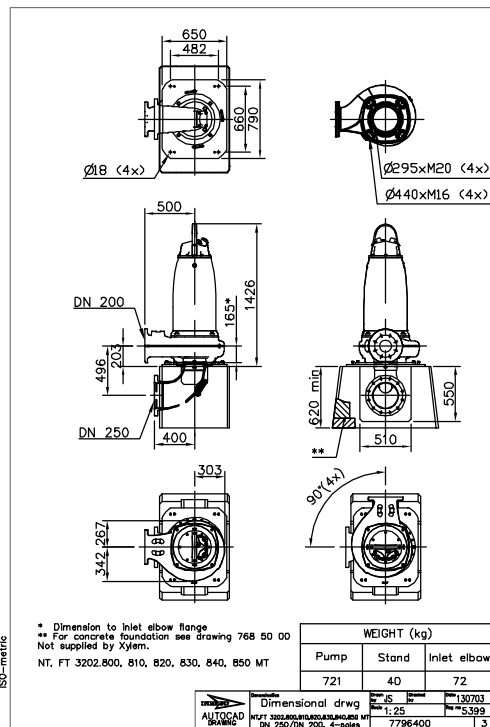

Figure 47: MT, T-installation

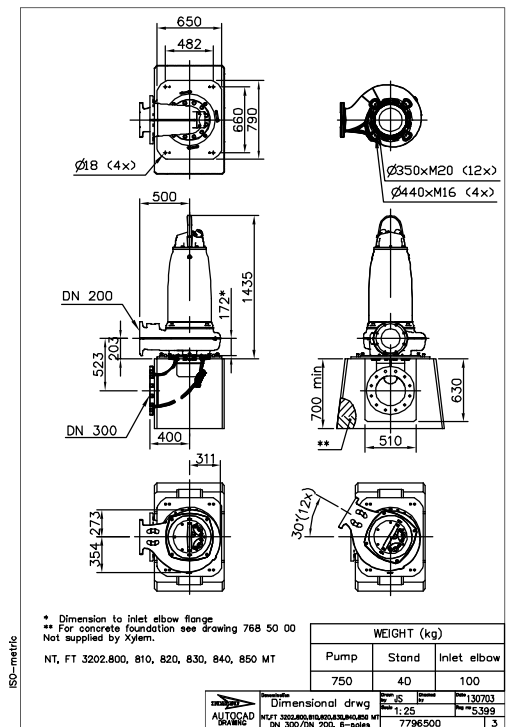

Figure 48: MT, T-installation

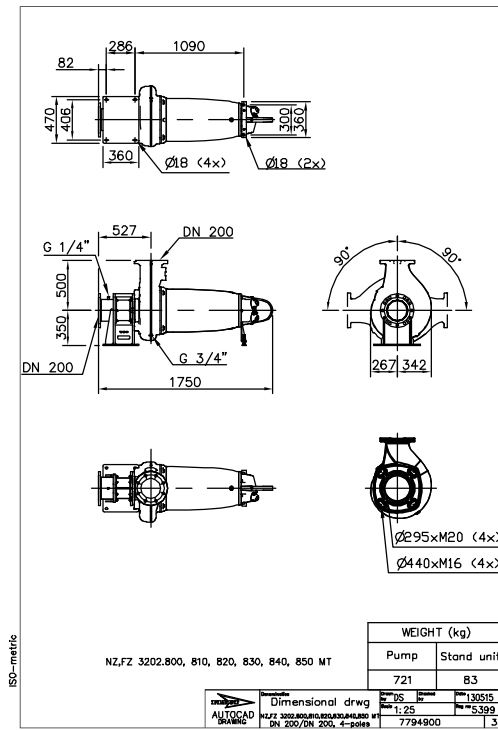

Figure 49: MT, Z-installation

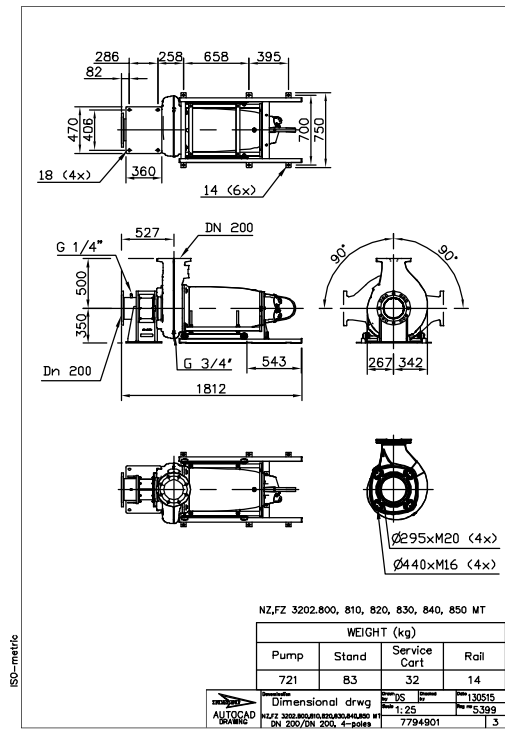

Figure 50: MT, Z-installation

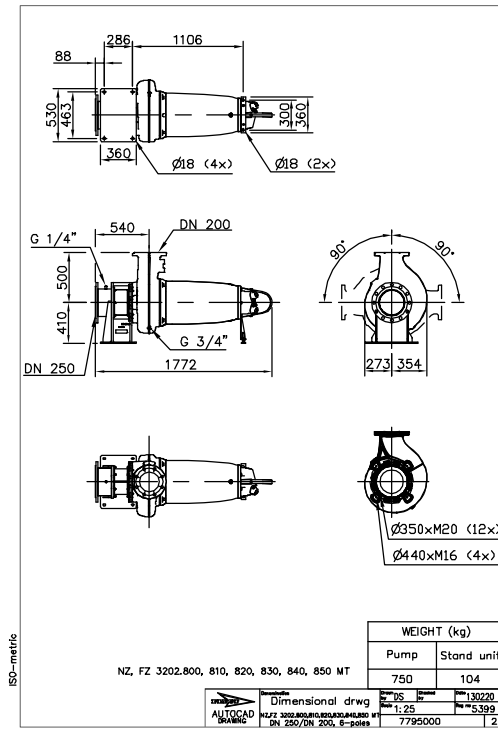

Figure 51: MT, Z-installation

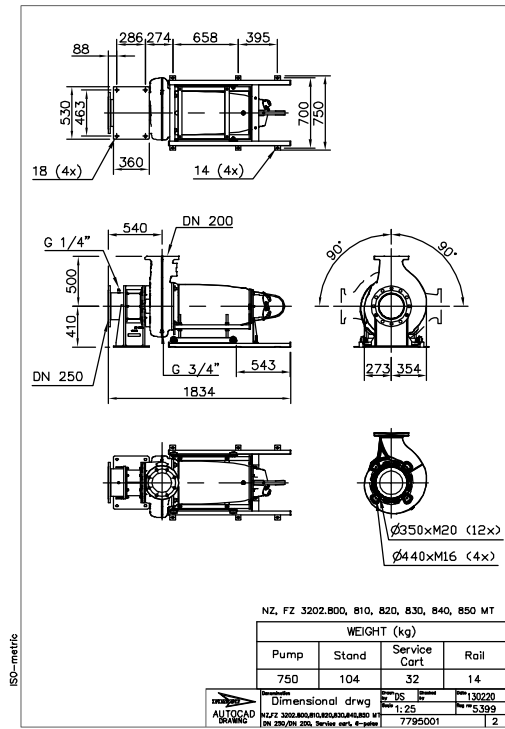

Figure 52: MT, Z-installation

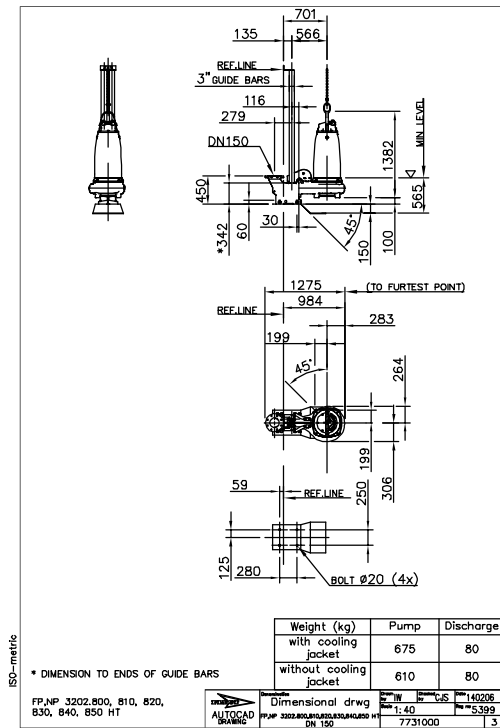

Figure 53: HT, P-installation

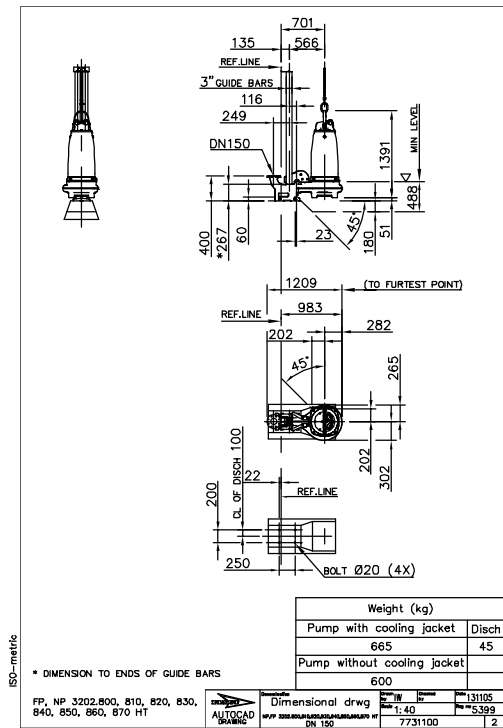

Figure 54: HT, P-installation

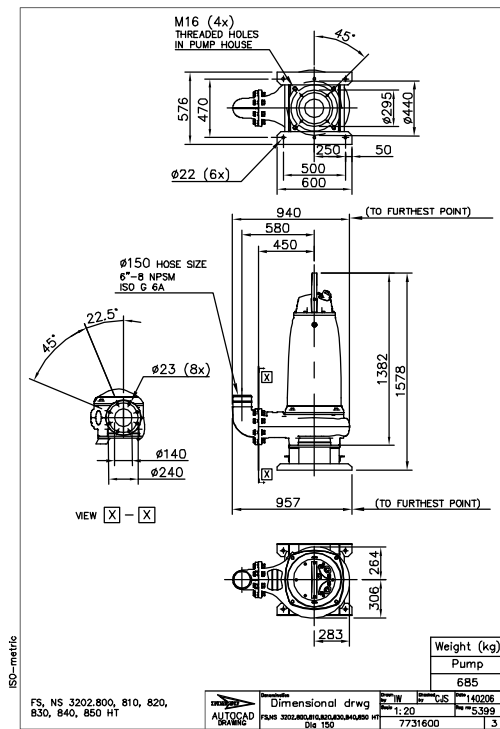

Figure 55: HT, S-installation

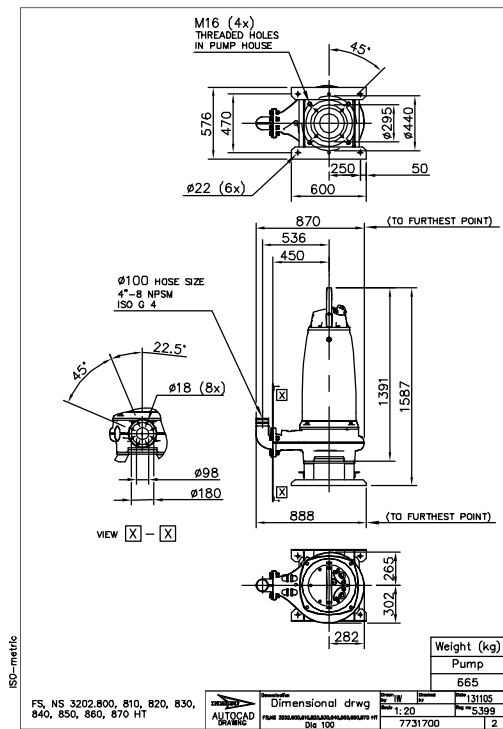

Figure 56: HT, S-installation

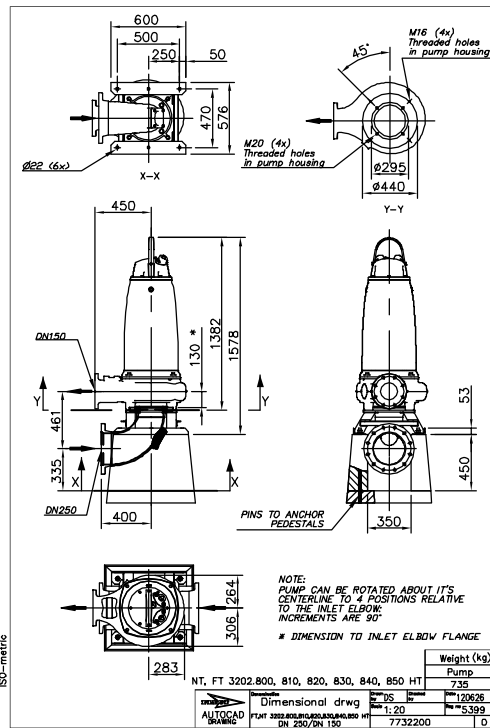

Figure 57: HT, T-installation

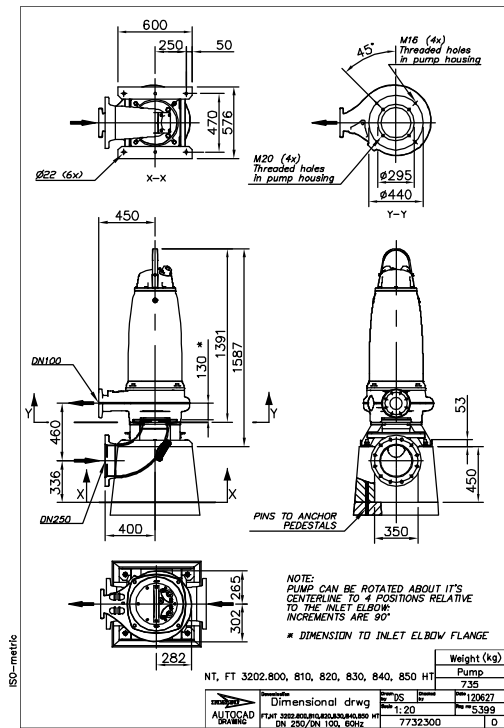

Figure 58: HT, T-installation

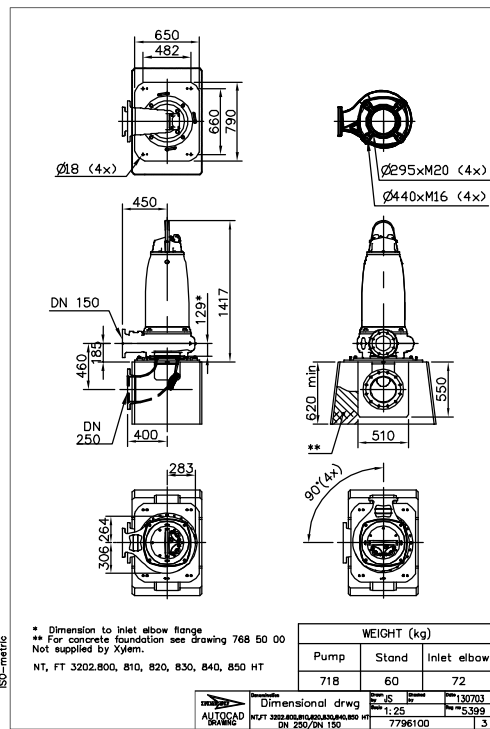

Figure 59: HT, T-installation

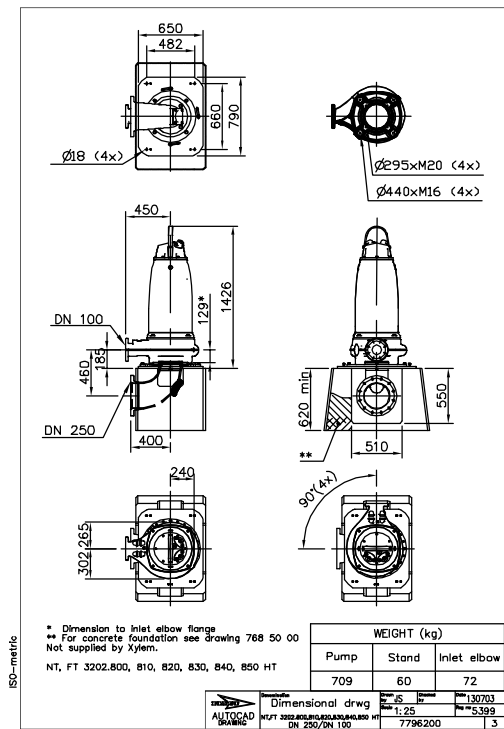

Figure 60: HT, T-installation

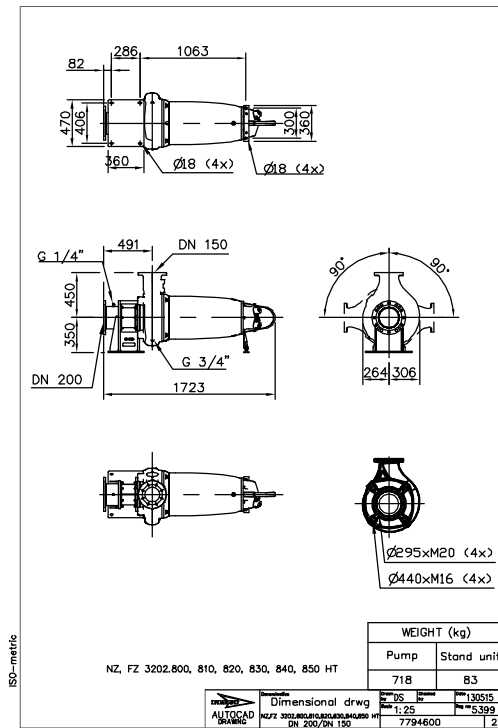

Figure 61: HT, Z-installation

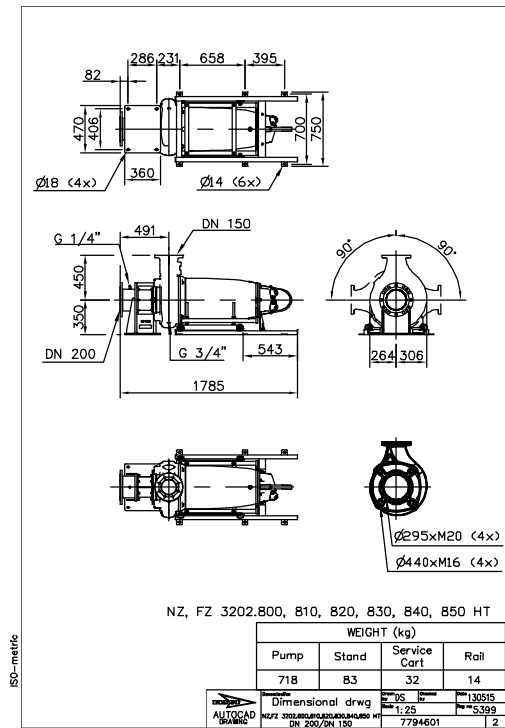

Figure 62: HT, Z-installation

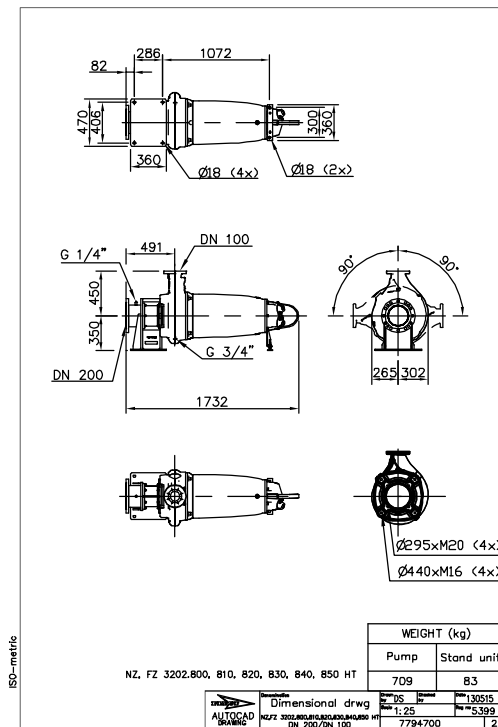

Figure 63: HT, Z-installation

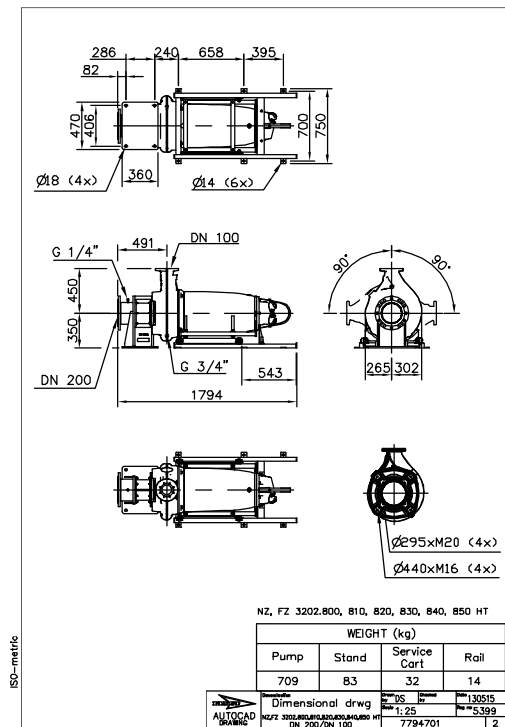

Figure 64: HT, Z-installation



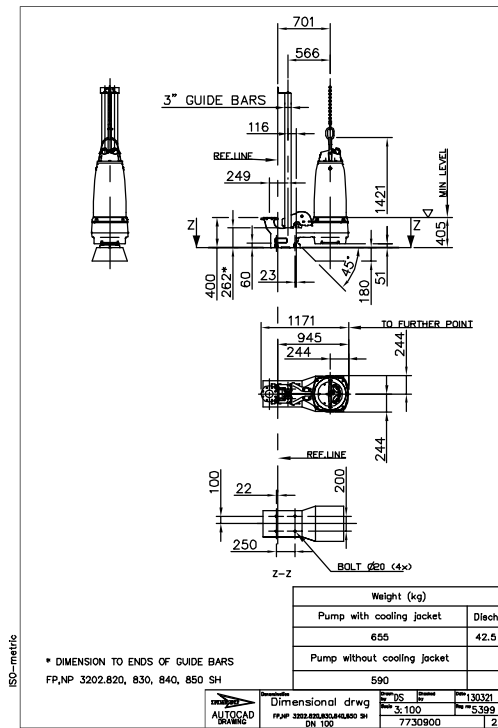

Figure 65: SH, P-installation

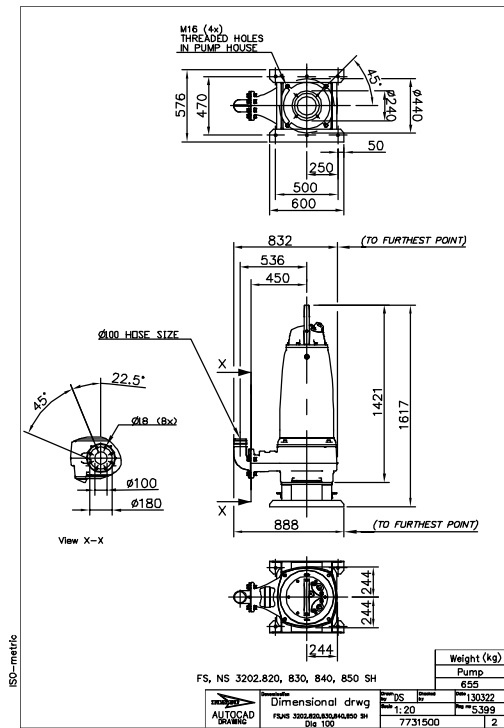

Figure 66: SH, S-installation

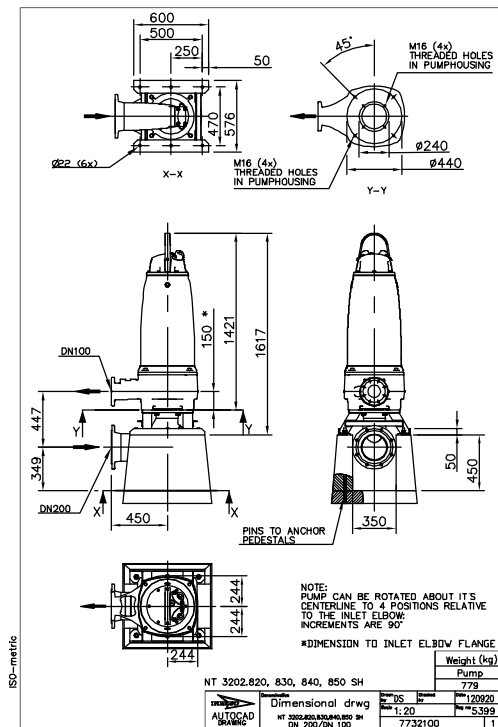

Figure 67: SH, T-installation

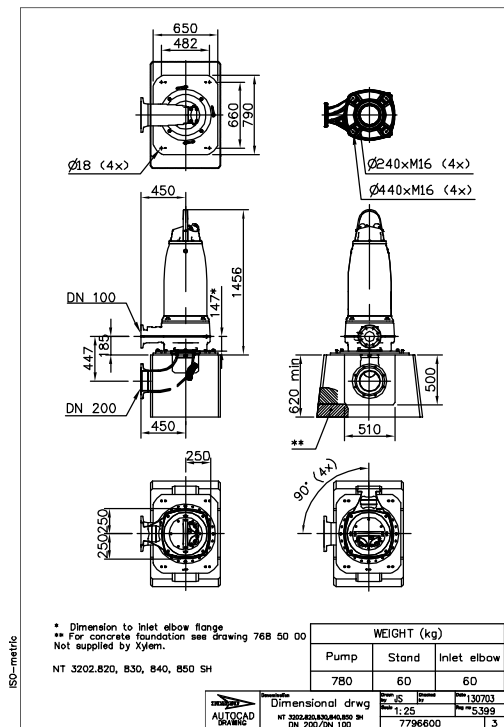

Figure 68: SH, T-installation

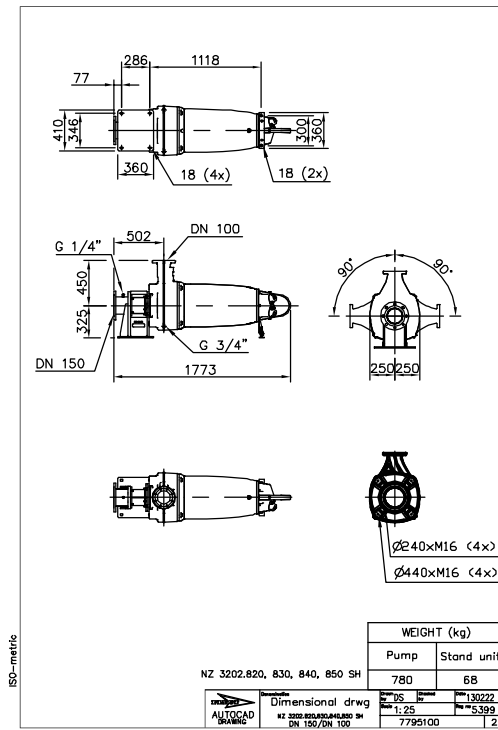

Figure 69: SH, Z-installation

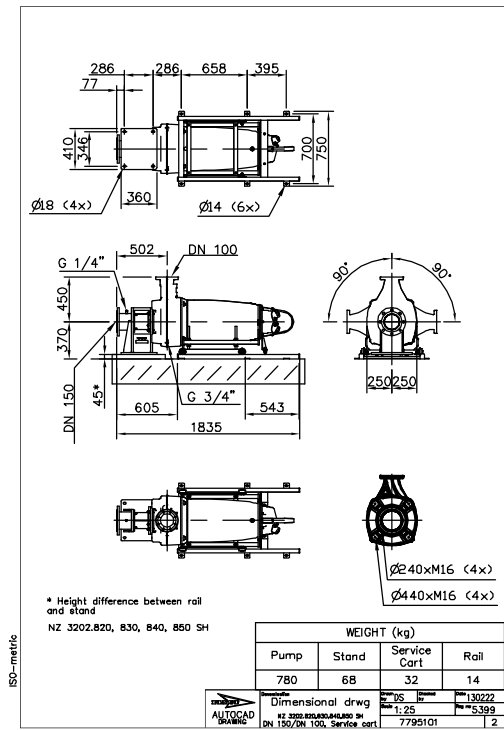

Figure 70: SH, Z-installation