



Flygt 3153, 50Hz



Table of Contents

F-pump, Standard Motor	2
Product description.....	2
Motor rating and performance curves.....	4
F-pump, Premium Efficiency Motor (IE3)	9
Product description.....	9
Motor rating and performance curves.....	11
N-pump, Standard Motor	15
Product description.....	15
Motor rating and performance curves 3153.181/.091/.185/.095.....	18
Motor rating and performance curves 3153.660/.670.....	22
N-pump, Premium Efficiency Motor (IE3)	24
Product description.....	24
Motor rating and performance curves 3153.800/.810/.820/.830.....	27
Motor rating and performance curves 3153.860/.870.....	30
Dimensions and Weight	33
Drawings.....	33

F-pump, Standard Motor

Product description



Usage

A submersible chopper pump for liquid manure, fish waste, or heavily contaminated sewage and sludge. The N-hydraulic is fitted with a cutting insert ring. Both impeller and insert ring are manufactured in Hard-Iron™.

Denomination

Type	Non-explosion proof version	Explosion proof version	Pressure class	Installation types
Hard-Iron™ Chopper	3153.350	3153.390	MT – Medium head HT – High head SH – Super head	P, S, T, Z

The pump can be used in the following installations:

- P Semi permanent, wet well arrangement with pump installed on two guide bars with automatic connection to discharge.
- S Portable semi permanent, wet well arrangement with hose coupling or flange for connection to discharge pipeline.
- T Vertical permanent, dry well arrangement with flange connection to suction and discharge piping.
- Z Horizontal permanent, dry well arrangement with flange connection to suction and discharge piping.

Application limits

Feature	Description
Liquid temperature	Maximum 40°C (104°F)
Liquid temperature, warm water version	Maximum 70°C (158°F)
Depth of immersion	Maximum 20 m (65 ft)
pH of the pumped liquid	5.5 - 14
Liquid density	Maximum 1100 kg/m ³

Motor data

Feature	Description
Motor type	Squirrel-cage induction motor
Frequency	50 Hz
Power supply	3-phase
Starting method	<ul style="list-style-type: none"> • Direct on-line • Star-delta • Variable Frequency Drive (VFD)
Number of starts per hour	Maximum 30
Code compliance	IEC 60034-1
Voltage variation	<ul style="list-style-type: none"> • Continuously running: Maximum $\pm 5\%$ • Intermittent running: Maximum $\pm 10\%$
Voltage imbalance between phases	Maximum 2%
Stator insulation class	H (180°C, 356°F)

Cables

Application	Type
Direct-on-line start or Y/D start with two cables	Flygt SUBCAB® - a heavy duty 4 cores motor power cable with two twisted pair screened control cores. Conductor insulation rating of 90°C, which allows for increased current. Superior mechanical strength and high abrasion and tear resistant. Chemical resistant within pH 3-10 and ozone, oil, and flame resistant. Used up to 70°C water temperature. Cables < 10 mm ² with unscreened control cores.
Y/D start	Flygt SUBCAB® - a heavy duty 7 cores motor power cable with two twisted pair screened control cores. Conductor insulation rating of 90°C, which allows for increased current. Superior mechanical strength and high abrasion and tear resistant. Chemical resistant within pH 3-10 and ozone, oil, and flame resistant. Used up to 70°C water temperature. Cables < 7G6 mm ² with unscreened control cores.
Variable Frequency drive	Screened Flygt SUBCAB® - a heavy duty 4 screened cores motor power cable with four twisted pair screened control cores. Conductor insulation rating of 90°C, which allows for increased current. Superior mechanical strength and high abrasion and tear resistant. Chemical resistant within pH 3-10 and ozone, oil, and flame resistant. Used up to 70°C water temperature.

Monitoring equipment

- Thermal contacts opening temperature 140° C (284° F)
- Leakage sensor in the inspection chamber (FLS 10)

Materials

Table 1: Major parts except mechanical seals

Denomination	Material	ASTM	EN
Major castings	Cast iron, gray	35B	GJL-250
Pump housing	Cast iron, gray	35B	GJL-250
Impeller	Cast iron, Hard-Iron™	A 532 IIIA	GJN-HB555(XCR23)
Insert ring	Cast iron, Hard-Iron™	A 532 IIIA	GJN-HB555(XCR23)

Denomination	Material	ASTM	EN
Cooling jacket, inner	Aluminum	AA 1050A	AW-1050A
Cooling jacket, outer, alternative 1	Steel	GR65	S235JRG2
Cooling jacket, outer, alternative 2	Stainless steel	AISI 316L	1.4404,1.4432, ...
Lifting handle	Stainless steel	AISI 316L	1.4404,1.4432, ...
Shaft	Stainless steel	AISI 431	1.4057+QT800
Screws and nuts	Stainless steel, A4	AISI 316L, 316, 316Ti	1.4401,1.4404, ...
O-rings, alternative 1	Nitrile rubber (NBR) 70° IRH	-	-
O-rings, alternative 2	Fluorinated rubber (FPM) 70° IRH	-	-
Glycol	Heat transfer fluid based on monopropylene glycol.	-	-

Table 2: Mechanical seals

Alternative	Inner seal	Outer seal
1	Corrosion resistant cemented carbide/ Corrosion resistant cemented carbide	Corrosion resistant cemented carbide/ Corrosion resistant cemented carbide
2	Corrosion resistant cemented carbide/ Corrosion resistant cemented carbide	Silicon carbide/ Silicon carbide

Surface treatment

Priming	Finish
Painted with a primer, see internal standard M0700.00.0002	Navy gray color NCS 5804-B07G. Two-component high-solid top coating, see internal standard M0700.00.0004 for standard painting and M0700.00.0008 for special painting.

Options

- Warm liquid version (non-explosion proof versions)
- Sensors: Thermistor, FLS, PT 100, VIS 10
- Feed control (chopper)
 - pressure class MT
- Aqua cutting knife (chopper)
 - pressure class MT, HT
- Surface treatment (Epoxy)
- Zinc anodes
- Other cables

Accessories

Discharge connections, adapters, hose connections, and other mechanical accessories. Electrical accessories such as pump controller, control panels, starters, monitoring relays, cables.

Motor rating and performance curves

These are examples of motor rating and curves. For more information, please contact your local sales and service representative.

Star-delta starting current is 1/3 of Direct on-line starting current.

MT

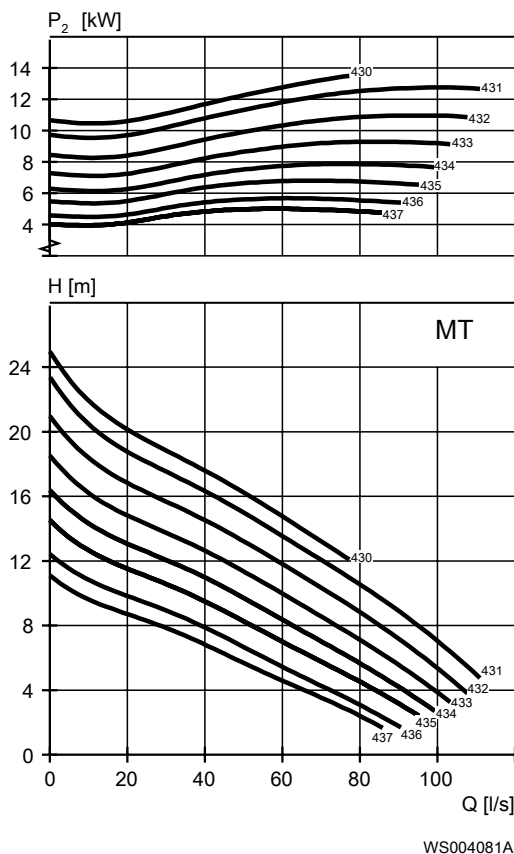

Figure 1: Manure

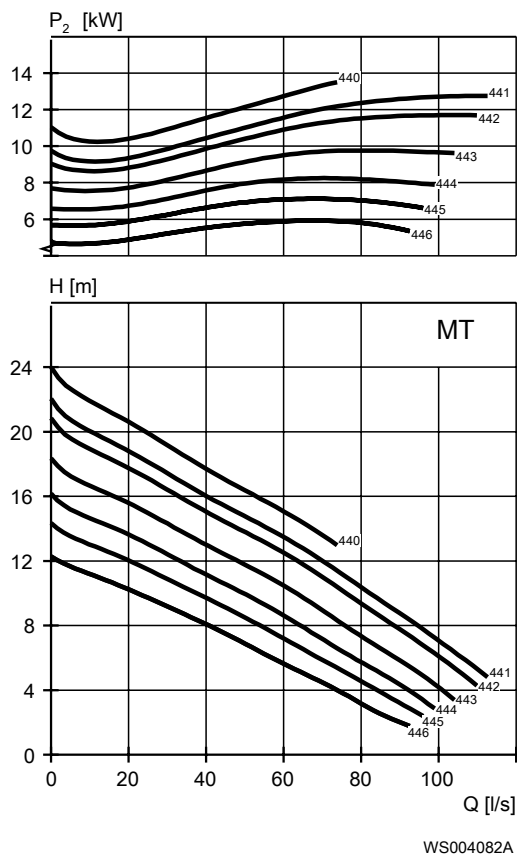

Figure 2: Long fibrous manure

Table 3: 400 V, 50 Hz, 3-phase

Rated power, kW	Rated power, hp	Curve/ Impeller No	Revolutions per minute, rpm	Rated current, A	Starting current, A	Power factor, cos φ	Installation
7.5	10.1	435	1465	16	107	0.76	P,S,T,Z
7.5	10.1	436	1465	16	107	0.76	P,S,T,Z
7.5	10.1	437	1465	16	107	0.76	P,S,T,Z
7.5	10.1	445	1465	16	107	0.76	P,S,T,Z
7.5	10.1	446	1465	16	107	0.76	P,S,T,Z
9	12.1	434	1460	19	107	0.8	P,S,T,Z
9	12.1	435	1460	19	107	0.8	P,S,T,Z
9	12.1	436	1460	19	107	0.8	P,S,T,Z
9	12.1	437	1460	19	107	0.8	P,S,T,Z
9	12.1	444	1460	19	107	0.8	P,S,T,Z
9	12.1	445	1460	19	107	0.8	P,S,T,Z
9	12.1	446	1460	19	107	0.8	P,S,T,Z
13.5	18.1	430	1455	27	145	0.82	P,S,T,Z
13.5	18.1	431	1455	27	145	0.82	P,S,T,Z
13.5	18.1	432	1455	27	145	0.82	P,S,T,Z
13.5	18.1	433	1455	27	145	0.82	P,S,T,Z
13.5	18.1	434	1455	27	145	0.82	P,S,T,Z

Rated power, kW	Rated power, hp	Curve/ Impeller No	Revolutions per minute, rpm	Rated current, A	Starting current, A	Power factor, cos φ	Installation
13.5	18.1	435	1455	27	145	0.82	P,S,T,Z
13.5	18.1	436	1455	27	145	0.82	P,S,T,Z
13.5	18.1	437	1455	27	145	0.82	P,S,T,Z
13.5	18.1	440	1455	27	145	0.82	P,S,T,Z
13.5	18.1	441	1455	27	145	0.82	P,S,T,Z
13.5	18.1	442	1455	27	145	0.82	P,S,T,Z
13.5	18.1	443	1455	27	145	0.82	P,S,T,Z
13.5	18.1	444	1455	27	145	0.82	P,S,T,Z
13.5	18.1	445	1455	27	145	0.82	P,S,T,Z
13.5	18.1	446	1455	27	145	0.82	P,S,T,Z

HT

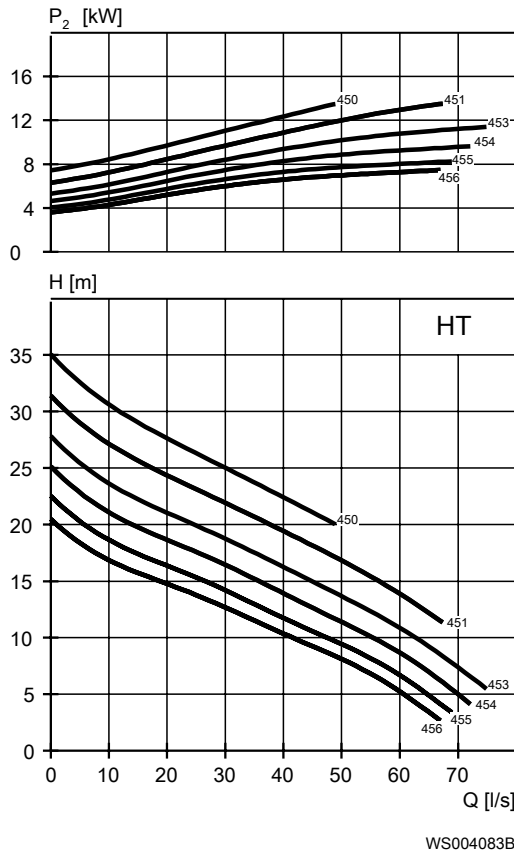

Figure 3: Manure

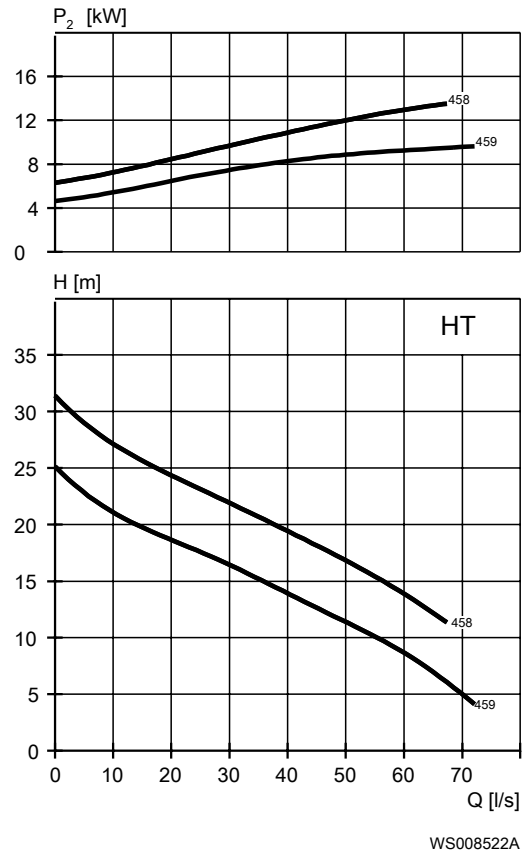

Figure 4: Long fibrous manure

Table 4: 400 V, 50 Hz, 3-phase

Rated power, kW	Rated power, hp	Curve/ Impeller No	Revolutions per minute, rpm	Rated current, A	Starting current, A	Power factor, cos φ	Installation
7.5	10.1	456	1465	16	107	0.76	P,S,T,Z
9	12.1	454	1460	19	107	0.8	P,S,T,Z
9	12.1	455	1460	19	107	0.8	P,S,T,Z
9	12.1	456	1460	19	107	0.8	P,S,T,Z

Rated power, kW	Rated power, hp	Curve/ Impeller No	Revolutions per minute, rpm	Rated current, A	Starting current, A	Power factor, cos φ	Installation
9	12.1	459	1460	19	107	0.8	P,S,T,Z
13.5	18.1	450	1455	27	145	0.82	P,S,T,Z
13.5	18.1	451	1455	27	145	0.82	P,S,T,Z
13.5	18.1	453	1455	27	145	0.82	P,S,T,Z
13.5	18.1	454	1455	27	145	0.82	P,S,T,Z
13.5	18.1	455	1455	27	145	0.82	P,S,T,Z
13.5	18.1	456	1455	27	145	0.82	P,S,T,Z
13.5	18.1	458	1455	27	145	0.82	P,S,T,Z
13.5	18.1	459	1455	27	145	0.82	P,S,T,Z

SH

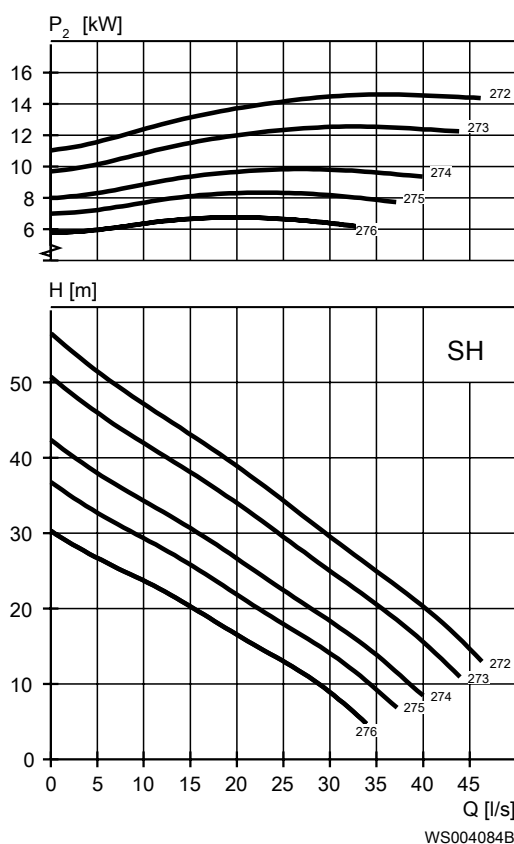

Figure 5: Manure

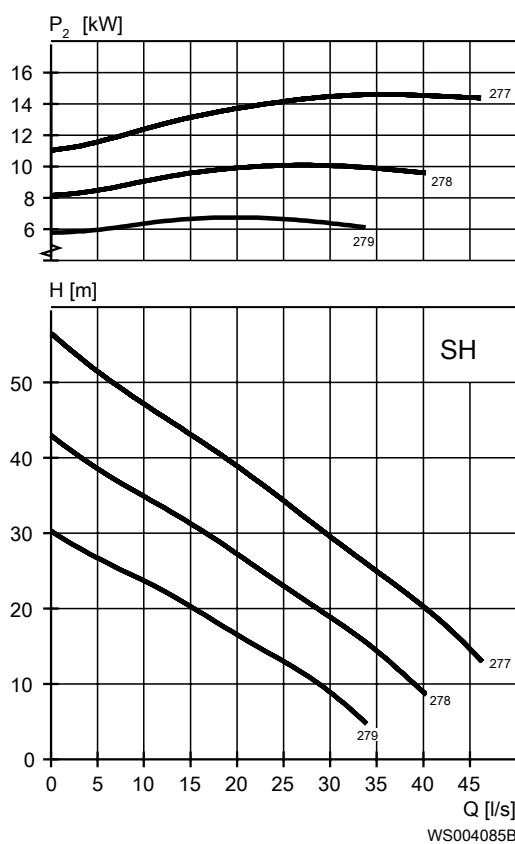

Figure 6: Long fibrous manure

Table 5: 400 V, 50 Hz, 3-phase

Rated power, kW	Rated power, hp	Curve/ Impeller No	Revolutions per minute, rpm	Rated current, A	Starting current, A	Power factor, cos φ	Installation
11	14.8	273	2905	19	139	0.94	P,S,T,Z
11	14.8	274	2905	19	139	0.94	P,S,T,Z
11	14.8	275	2905	19	139	0.94	P,S,T,Z
11	14.8	276	2905	19	139	0.94	P,S,T,Z
11	14.8	278	2905	19	139	0.94	P,S,T,Z

Rated power, kW	Rated power, hp	Curve/ Impeller No	Revolutions per minute, rpm	Rated current, A	Starting current, A	Power factor, cos ϕ	Installation
11	14.8	279	2905	19	139	0.94	P,S,T,Z
15	20	272	2910	27	213	0.89	P,S,T,Z
15	20	273	2910	27	213	0.89	P,S,T,Z
15	20	274	2910	27	213	0.89	P,S,T,Z
15	20	275	2910	27	213	0.89	P,S,T,Z
15	20	276	2910	27	213	0.89	P,S,T,Z
15	20	277	2910	27	213	0.89	P,S,T,Z
15	20	278	2910	27	213	0.89	P,S,T,Z
15	20	279	2910	27	213	0.89	P,S,T,Z

F-pump, Premium Efficiency Motor (IE3)

Product description



Usage

A submersible chopper pump for liquid manure, fish waste, or heavily contaminated sewage and sludge. The N-hydraulic is fitted with a cutting insert ring. Both impeller and insert ring are manufactured in Hard-Iron™.

Denomination

Type	Non-explosion proof version	Explosion proof version	Pressure class	Installation types
Hard-Iron™ Chopper	3153.840	3153.850	MT – Medium head HT – High head SH – Super head	P, S, T, Z

The pump can be used in the following installations:

- P Semi permanent, wet well arrangement with pump installed on two guide bars with automatic connection to discharge.
- S Portable semi permanent, wet well arrangement with hose coupling or flange for connection to discharge pipeline.
- T Vertical permanent, dry well arrangement with flange connection to suction and discharge piping.
- Z Horizontal permanent, dry well arrangement with flange connection to suction and discharge piping.

Application limits

Feature	Description
Liquid temperature	Maximum 40°C (104°F)
Depth of immersion	Maximum 20 m (65 ft)
pH of the pumped liquid	5.5 - 14
Liquid density	Maximum 1100 kg/m ³

Motor data

Feature	Description
Motor type	Line started permanent magnet motor (LSPM) Squirrel-cage induction motor
Frequency	50 Hz
Power supply	3-phase
Starting method	<ul style="list-style-type: none"> • Direct on-line • Star-delta • Variable Frequency Drive (VFD)
Number of starts per hour	Maximum 30
Code compliance	IEC 60034-1
Voltage variation	<ul style="list-style-type: none"> • Continuously running: Maximum $\pm 5\%$ • Intermittent running: Maximum $\pm 10\%$
Voltage imbalance between phases	Maximum 2%
Stator insulation class	H (180°C, 356°F)

Cables

Application	Type
Direct-on-line start or Y/D start with two cables	Flygt SUBCAB® - a heavy duty 4 cores motor power cable with two twisted pair screened control cores. Conductor insulation rating of 90°C, which allows for increased current. Superior mechanical strength and high abrasion and tear resistant. Chemical resistant within pH 3-10 and ozone, oil, and flame resistant. Used up to 70°C water temperature. Cables < 10 mm ² with unscreened control cores.
Y/D start	Flygt SUBCAB® - a heavy duty 7 cores motor power cable with two twisted pair screened control cores. Conductor insulation rating of 90°C, which allows for increased current. Superior mechanical strength and high abrasion and tear resistant. Chemical resistant within pH 3-10 and ozone, oil, and flame resistant. Used up to 70°C water temperature. Cables < 7G6 mm ² with unscreened control cores.
Variable Frequency drive	Screened Flygt SUBCAB® - a heavy duty 4 screened cores motor power cable with four twisted pair screened control cores. Conductor insulation rating of 90°C, which allows for increased current. Superior mechanical strength and high abrasion and tear resistant. Chemical resistant within pH 3-10 and ozone, oil, and flame resistant. Used up to 70°C water temperature.

Monitoring equipment

- Thermal contacts opening temperature 140° C (284° F)
- Leakage sensor in the inspection chamber (FLS 10)

Materials

Table 6: Major parts except mechanical seals

Denomination	Material	ASTM	EN
Major castings	Cast iron, gray	35B	GJL-250
Pump housing	Cast iron, gray	35B	GJL-250
Impeller	Cast iron, Hard-Iron™	A 532 IIIA	GJN-HB555(XCR23)

Denomination	Material	ASTM	EN
Insert ring	Cast iron, Hard-Iron™	A 532 IIIA	GJN-HB555(XCR23)
Cooling jacket, inner	Aluminum	AA 1050A	AW-1050A
Cooling jacket, outer, alternative 1	Steel	GR65	S235JRG2
Cooling jacket, outer, alternative 2	Stainless steel	AISI 316L	1.4404,1.4432, ...
Lifting handle	Stainless steel	AISI 316L	1.4404,1.4432, ...
Shaft	Stainless steel	AISI 431	1.4057+QT800
Screws and nuts	Stainless steel, A4	AISI 316L, 316, 316Ti	1.4401,1.4404, ...
O-rings, alternative 1	Nitrile rubber (NBR) 70° IRH	-	-
O-rings, alternative 2	Fluorinated rubber (FPM) 70° IRH	-	-
Glycol	Heat transfer fluid based on monopropylene glycol.	-	-

Table 7: Mechanical seals

Alternative	Inner seal	Outer seal
1	Corrosion resistant cemented carbide/ Corrosion resistant cemented carbide	Corrosion resistant cemented carbide/ Corrosion resistant cemented carbide
2	Corrosion resistant cemented carbide/ Corrosion resistant cemented carbide	Silicon carbide/ Silicon carbide

Surface treatment

Priming	Finish
Painted with a primer, see internal standard M0700.00.0002	Navy gray color NCS 5804-B07G. Two-component high-solid top coating, see internal standard M0700.00.0004 for standard painting and M0700.00.0008 for special painting.

Options

- Sensors: Thermistor, FLS, PT 100, VIS 10
- Feed control (chopper)
 - pressure class MT
- Aqua cutting knife (chopper)
 - pressure class MT, HT
- Surface treatment (Epoxy)
- Zinc anodes
- Other cables

Accessories

Discharge connections, adapters, hose connections, and other mechanical accessories. Electrical accessories such as pump controller, control panels, starters, monitoring relays, cables.

Motor rating and performance curves

These are examples of motor rating and curves. For more information, please contact your local sales and service representative.

Star-delta starting current is 1/3 of Direct on-line starting current.

MT

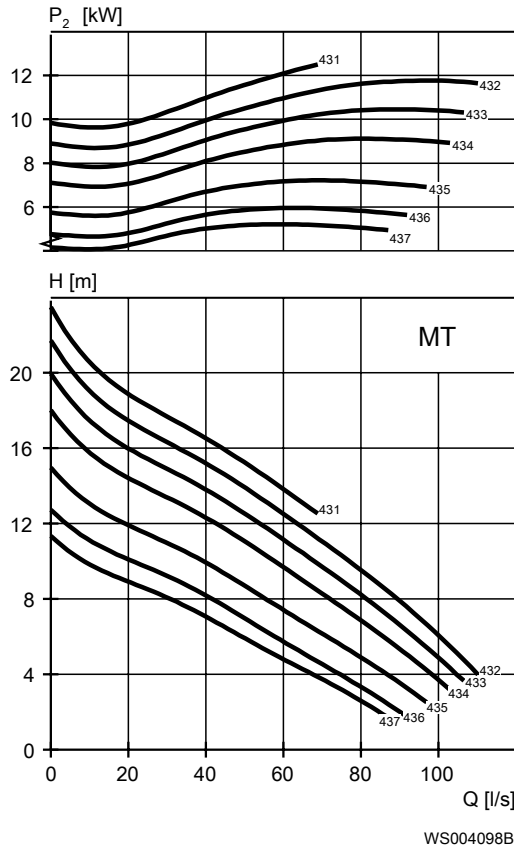

Figure 7: Manure

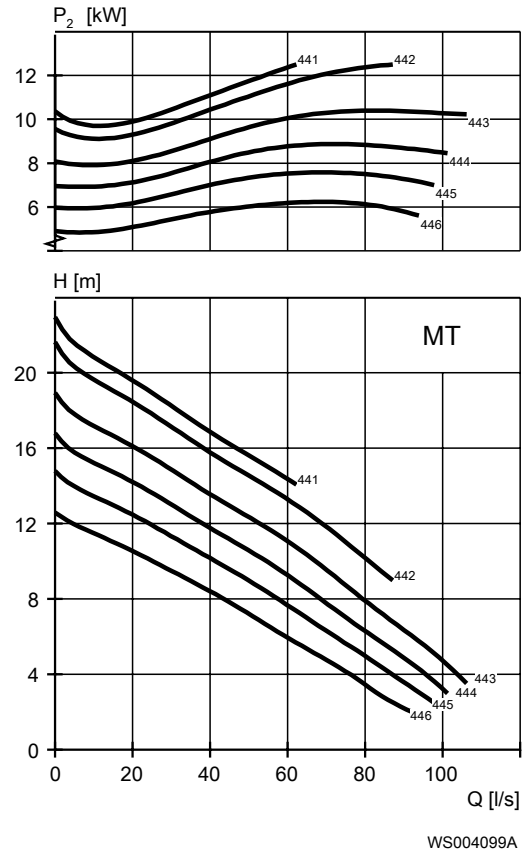

Figure 8: Long fibrous manure

Table 8: 400 V, 50 Hz, 3-phase

Rated power, kW	Rated power, hp	Curve/ Impeller No	Revolutions per minute, rpm	Rated current, A	Starting current, A	Power factor, cos φ	Installation
12.5	16.8	431	1500	21	145	0.95	P,S,T,Z
12.5	16.8	432	1500	21	145	0.95	P,S,T,Z
12.5	16.8	433	1500	21	145	0.95	P,S,T,Z
12.5	16.8	434	1500	21	145	0.95	P,S,T,Z
12.5	16.8	435	1500	21	145	0.95	P,S,T,Z
12.5	16.8	436	1500	21	145	0.95	P,S,T,Z
12.5	16.8	437	1500	21	145	0.95	P,S,T,Z
12.5	16.8	441	1500	21	145	0.95	P,S,T,Z
12.5	16.8	442	1500	21	145	0.95	P,S,T,Z
12.5	16.8	443	1500	21	145	0.95	P,S,T,Z
12.5	16.8	444	1500	21	145	0.95	P,S,T,Z
12.5	16.8	445	1500	21	145	0.95	P,S,T,Z
12.5	16.8	446	1500	21	145	0.95	P,S,T,Z

HT

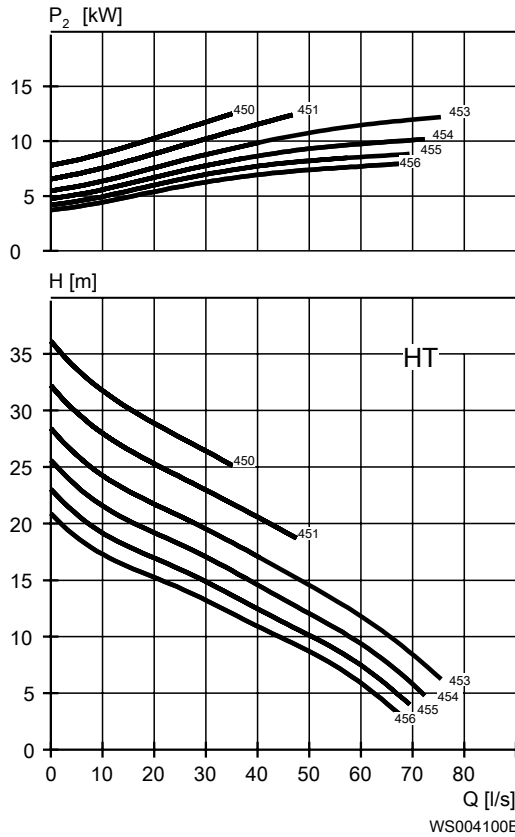

Figure 9: Manure

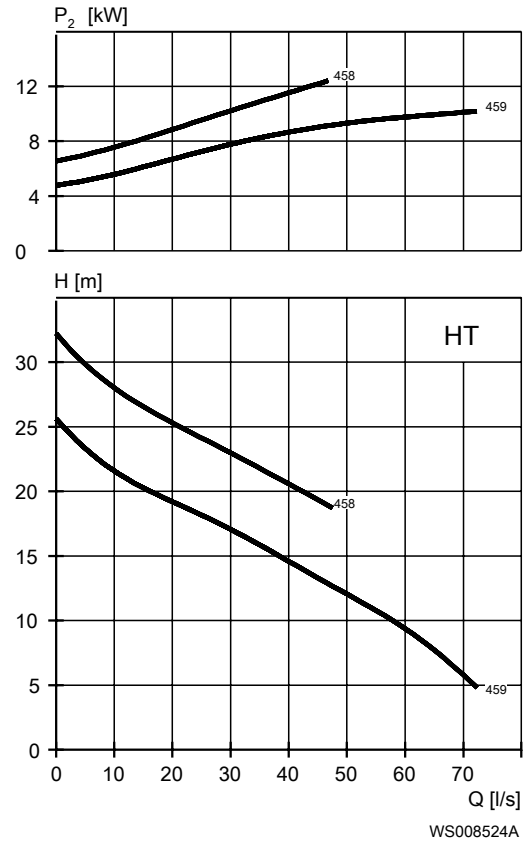

Figure 10: Long fibrous manure

Table 9: 400 V, 50 Hz, 3-phase

Rated power, kW	Rated power, hp	Curve/ Impeller No	Revolutions per minute, rpm	Rated current, A	Starting current, A	Power factor, cos φ	Installation
12.5	16.8	450	1500	21	145	0.95	P,S,T,Z
12.5	16.8	451	1500	21	145	0.95	P,S,T,Z
12.5	16.8	453	1500	21	145	0.95	P,S,T,Z
12.5	16.8	454	1500	21	145	0.95	P,S,T,Z
12.5	16.8	455	1500	21	145	0.95	P,S,T,Z
12.5	16.8	456	1500	21	145	0.95	P,S,T,Z
12.5	16.8	458	1500	21	145	0.95	P,S,T,Z
12.5	16.8	459	1500	21	145	0.95	P,S,T,Z

SH

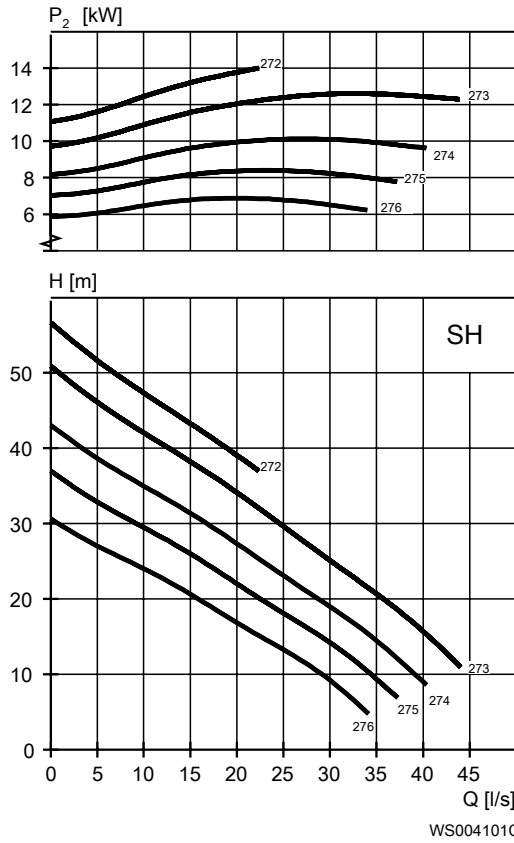

Figure 11: Manure

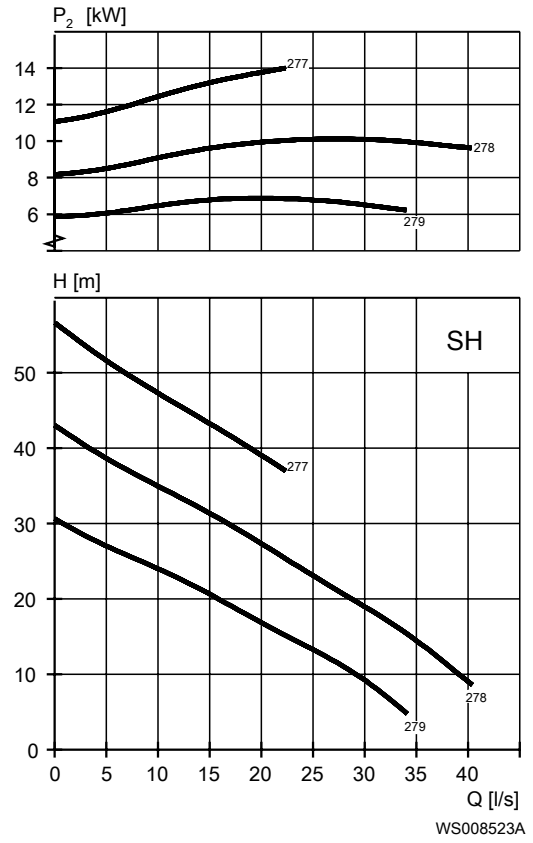

Figure 12: Long fibrous manure

Table 10: 400 V, 50 Hz, 3-phase

Rated power, kW	Rated power, hp	Curve/ Impeller No	Revolutions per minute, rpm	Rated Current, A	Start current, A	Power Factor, $\cos \varphi$	Installation
11	14.8	273	2915	19	147	0.93	P,S,T,Z
11	14.8	274	2915	19	147	0.93	P,S,T,Z
11	14.8	275	2915	19	147	0.93	P,S,T,Z
11	14.8	276	2915	19	147	0.93	P,S,T,Z
11	14.8	278	2915	19	147	0.93	P,S,T,Z
11	14.8	279	2915	19	147	0.93	P,S,T,Z
14	18.8	272	2925	25	214	0.88	P,S,T,Z
14	18.8	273	2925	25	214	0.88	P,S,T,Z
14	18.8	274	2925	25	214	0.88	P,S,T,Z
14	18.8	275	2925	25	214	0.88	P,S,T,Z
14	18.8	276	2925	25	214	0.88	P,S,T,Z
14	18.8	277	2925	25	214	0.88	P,S,T,Z
14	18.8	278	2925	25	214	0.88	P,S,T,Z
14	18.8	279	2925	25	214	0.88	P,S,T,Z

N-pump, Standard Motor

Product description



Usage

A submersible pump for efficient pumping of clean water, surface water, and wastewater containing solids or long-fibered material. The pump is designed for sustained high efficiency. For abrasive media, Hard-Iron™ is required. Stainless steel N-impeller is available as an option.

Denomination

Type	Non-explosion proof version	Explosion proof version	Pressure class	Installation types
Cast iron	3153.181	3153.091	LT – Low head MT – Medium head HT – High head SH – Super head	P, S, T, Z
Hard-Iron™	3153.185	3153.095	LT – Low head MT – Medium head HT – High head SH – Super head	P, S, T, Z
Stainless steel	3153.660	3153.670	MT – Medium head HT – High head	P, S

The pump can be used in the following installations:

- P Semi permanent, wet well arrangement with pump installed on two guide bars with automatic connection to discharge.
- S Portable semi permanent, wet well arrangement with hose coupling or flange for connection to discharge pipeline.
- T Vertical permanent, dry well arrangement with flange connection to suction and discharge piping.
- Z Horizontal permanent, dry well arrangement with flange connection to suction and discharge piping.

Application limits

Feature	Description
Liquid temperature	Maximum 40°C (104°F)
Liquid temperature, warm water version	Maximum 70°C (158°F)
Depth of immersion	Maximum 20 m (65 ft)
pH of the pumped liquid	5.5 - 14
Liquid density	Maximum 1100 kg/m ³

Motor data

Feature	Description
Motor type	Squirrel-cage induction motor
Frequency	50 Hz
Power supply	3-phase
Starting method	<ul style="list-style-type: none"> • Direct on-line • Star-delta • Variable Frequency Drive (VFD)
Number of starts per hour	Maximum 30
Code compliance	IEC 60034-1
Voltage variation	<ul style="list-style-type: none"> • Continuously running: Maximum $\pm 5\%$ • Intermittent running: Maximum $\pm 10\%$
Voltage imbalance between phases	Maximum 2%
Stator insulation class	H (180°C, 356°F)

Cables

Application	Type
Direct-on-line start or Y/D start with two cables	Flygt SUBCAB® - a heavy duty 4 cores motor power cable with two twisted pair screened control cores. Conductor insulation rating of 90°C, which allows for increased current. Superior mechanical strength and high abrasion and tear resistant. Chemical resistant within pH 3-10 and ozone, oil, and flame resistant. Used up to 70°C water temperature. Cables < 10 mm ² with unscreened control cores.
Y/D start	Flygt SUBCAB® - a heavy duty 7 cores motor power cable with two twisted pair screened control cores. Conductor insulation rating of 90°C, which allows for increased current. Superior mechanical strength and high abrasion and tear resistant. Chemical resistant within pH 3-10 and ozone, oil, and flame resistant. Used up to 70°C water temperature. Cables < 7G6 mm ² with unscreened control cores.
Variable Frequency drive	Screened Flygt SUBCAB® - a heavy duty 4 screened cores motor power cable with four twisted pair screened control cores. Conductor insulation rating of 90°C, which allows for increased current. Superior mechanical strength and high abrasion and tear resistant. Chemical resistant within pH 3-10 and ozone, oil, and flame resistant. Used up to 70°C water temperature.

Monitoring equipment

- Thermal contacts opening temperature 140° C (284° F)
- Leakage sensor in the inspection chamber (FLS 10)

Materials

Table 11: Major parts except mechanical seals

Denomination	Material	ASTM	EN
Major castings	Cast iron, gray	35B	GJL-250
Pump housing	Cast iron, gray	35B	GJL-250
Impeller, alternative 1	Cast iron, gray	35B	GJL-250
Impeller, alternative 2	Cast iron, Hard-Iron™	A 532 IIIA	GJN-HB555(XCR23)
Impeller, alternative 3	Stainless steel, Duplex	CD-4MCuN	10283:2010 -1.4474
Insert ring, alternative 1	Cast iron, gray	35B	GJL-250
Insert ring, alternative 2	Cast iron, Hard-Iron™	A 532 IIIA	GJN-HB555(XCR23)
Cooling jacket, inner	Aluminum	AA 1050A	AW-1050A
Cooling jacket, outer, alternative 1	Steel	GR65	S235JRG2
Cooling jacket, outer, alternative 2	Stainless steel	AISI 316L	1.4404,1.4432, ...
Lifting handle	Stainless steel	AISI 316L	1.4404,1.4432, ...
Shaft	Stainless steel	AISI 431	1.4057+QT800
Screws and nuts	Stainless steel, A4	AISI 316L, 316, 316Ti	1.4401,1.4404, ...
O-rings, alternative 1	Nitrile rubber (NBR) 70° IRH	-	-
O-rings, alternative 2	Fluorinated rubber (FPM) 70° IRH	-	-
Glycol	Heat transfer fluid based on monopropylene glycol.	-	-

Table 12: Mechanical seals

Alternative	Inner seal	Outer seal
1	Corrosion resistant cemented carbide/ Corrosion resistant cemented carbide	Corrosion resistant cemented carbide/ Corrosion resistant cemented carbide
2	Corrosion resistant cemented carbide/ Corrosion resistant cemented carbide	Silicon carbide/ Silicon carbide

Surface treatment

Priming	Finish
Painted with a primer, see internal standard M0700.00.0002	Navy gray color NCS 5804-B07G. Two-component high-solid top coating, see internal standard M0700.00.0004 for standard painting and M0700.00.0008 for special painting.

Options

- Warm liquid version (non-explosion proof versions)
- Sensors: Thermistor, FLS, PT 100, VIS 10
- Surface treatment (Epoxy)
- Zinc anodes
- Other cables

Accessories

Discharge connections, adapters, hose connections, and other mechanical accessories.

Electrical accessories such as pump controller, control panels, starters, monitoring relays, cables.

Motor rating and performance curves 3153.181/.091/.185/.095

These are examples of motor rating and curves. For more information, please contact your local sales and service representative.

Star-delta starting current is 1/3 of Direct on-line starting current.

LT

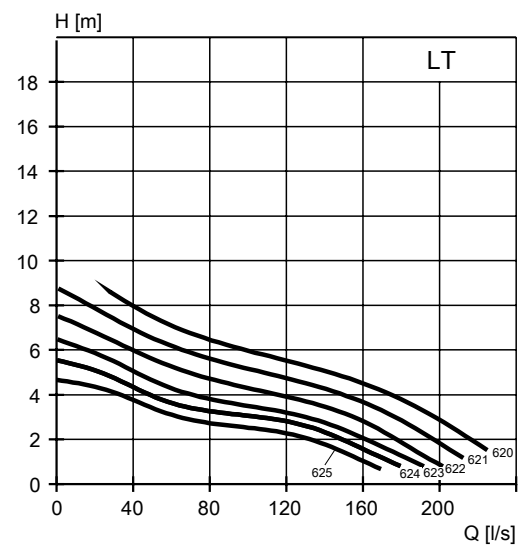
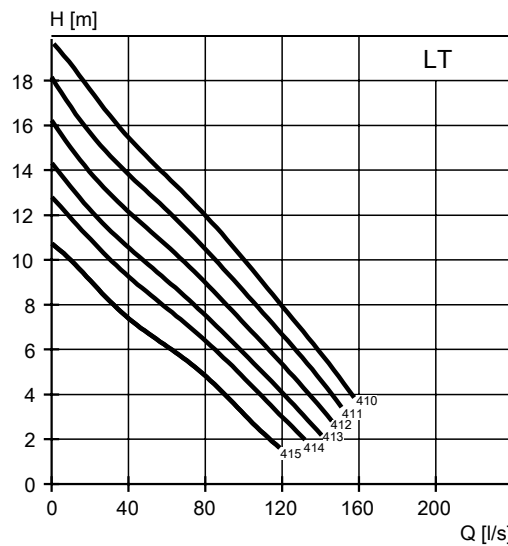
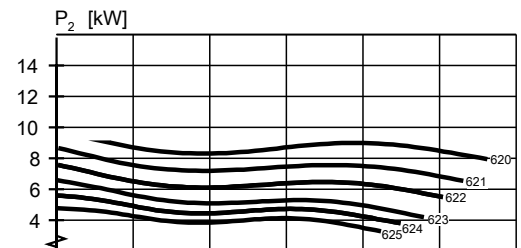
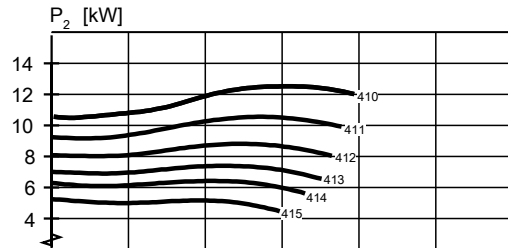

WS004070A

WS004071A

Table 13: 400 V, 50 Hz, 3-phase

Rated power, kW	Rated power, hp	Curve/ Impeller No	Revolutions per minute, rpm	Rated current, A	Starting current, A	Power factor, cos φ	Installation
7.5	10.1	413	1465	16	107	0.76	P,S,T,Z
7.5	10.1	414	1465	16	107	0.76	P,S,T,Z
7.5	10.1	415	1465	16	107	0.76	P,S,T,Z
9	12.1	412	1460	19	107	0.8	P,S,T,Z
9	12.1	413	1460	19	107	0.8	P,S,T,Z
9	12.1	414	1460	19	107	0.8	P,S,T,Z
9	12.1	415	1460	19	107	0.8	P,S,T,Z
9	12.1	620	955	21	90	0.72	P,S,T,Z
9	12.1	620	955	21	90	0.72	P,S,T,Z
9	12.1	622	955	21	90	0.72	P,S,T,Z
9	12.1	623	955	21	90	0.72	P,S,T,Z

Rated power, kW	Rated power, hp	Curve/ Impeller No	Revolutions per minute, rpm	Rated current, A	Starting current, A	Power factor, cos φ	Installation
9	12.1	624	955	21	90	0.72	P,S,T,Z
9	12.1	625	955	21	90	0.72	P,S,T,Z
13.5	18.1	410	1455	27	145	0.82	P,S,T,Z
13.5	18.1	411	1455	27	145	0.82	P,S,T,Z
13.5	18.1	412	1455	27	145	0.82	P,S,T,Z
13.5	18.1	413	1455	27	145	0.82	P,S,T,Z
13.5	18.1	414	1455	27	145	0.82	P,S,T,Z
13.5	18.1	415	1455	27	145	0.82	P,S,T,Z

MT

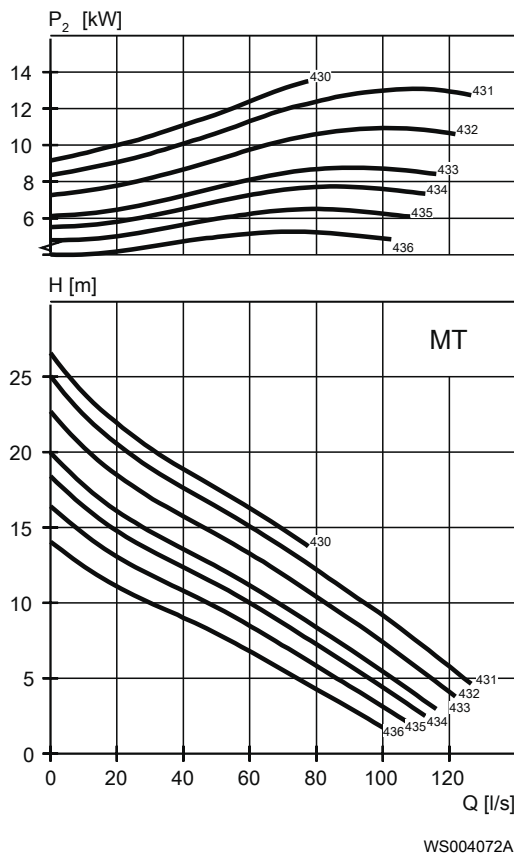

Table 14: 400 V, 50 Hz, 3-phase

Rated power, kW	Rated power, hp	Curve/ Impeller No	Revolutions per minute, rpm	Rated current, A	Starting current, A	Power factor, cos φ	Installation
7.5	10.1	434	1465	16	107	0.76	P,S,T,Z
7.5	10.1	435	1465	16	107	0.76	P,S,T,Z
7.5	10.1	436	1465	16	107	0.76	P,S,T,Z
9	12.1	433	1460	19	107	0.8	P,S,T,Z
9	12.1	434	1460	19	107	0.8	P,S,T,Z
9	12.1	435	1460	19	107	0.8	P,S,T,Z
9	12.1	436	1460	19	107	0.8	P,S,T,Z
13.5	18.1	430	1455	27	145	0.82	P,S,T,Z

Rated power, kW	Rated power, hp	Curve/ Impeller No	Revolutions per minute, rpm	Rated current, A	Starting current, A	Power factor, cos φ	Installation
13.5	18.1	431	1455	27	145	0.82	P,S,T,Z
13.5	18.1	432	1455	27	145	0.82	P,S,T,Z
13.5	18.1	433	1455	27	145	0.82	P,S,T,Z
13.5	18.1	434	1455	27	145	0.82	P,S,T,Z
13.5	18.1	435	1455	27	145	0.82	P,S,T,Z
13.5	18.1	436	1455	27	145	0.82	P,S,T,Z

HT

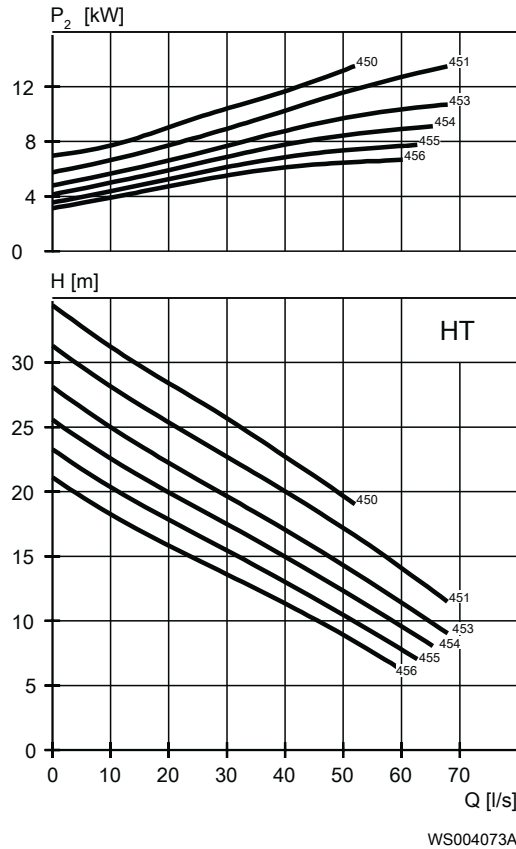
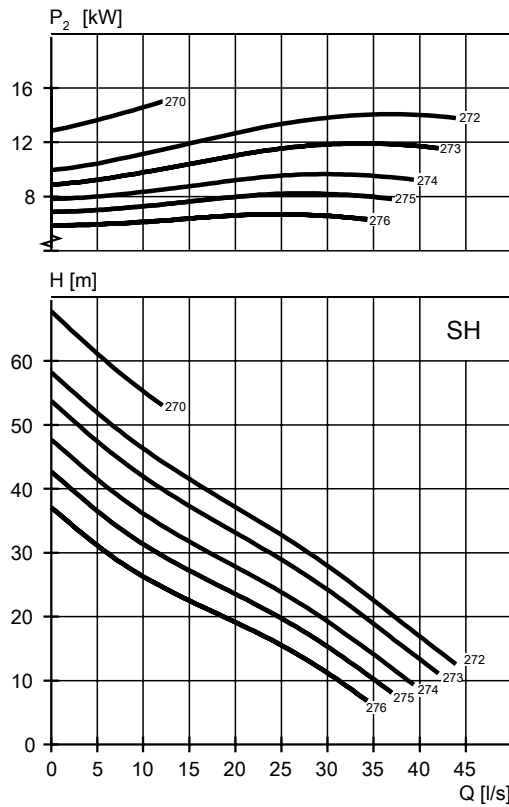

Table 15: 400 V, 50 Hz, 3-phase

Rated power, kW	Rated power, hp	Curve/ Impeller No	Revolutions per minute, rpm	Rated current, A	Starting current, A	Power factor, cos φ	Installation
7.5	10.1	451	1465	16	107	0.76	P,S,T,Z
7.5	10.1	453	1465	16	107	0.76	P,S,T,Z
7.5	10.1	454	1465	16	107	0.76	P,S,T,Z
7.5	10.1	455	1465	16	107	0.76	P,S,T,Z
7.5	10.1	456	1465	16	107	0.76	P,S,T,Z
9	12.1	450	1460	19	107	0.8	P,S,T,Z
9	12.1	451	1460	19	107	0.8	P,S,T,Z
9	12.1	453	1460	19	107	0.8	P,S,T,Z
9	12.1	454	1460	19	107	0.8	P,S,T,Z
9	12.1	455	1460	19	107	0.8	P,S,T,Z

Rated power, kW	Rated power, hp	Curve/ Impeller No	Revolutions per minute, rpm	Rated current, A	Starting current, A	Power factor, cos φ	Installation
9	12.1	456	1460	19	107	0.8	P,S,T,Z
13.5	18.1	450	1455	27	145	0.82	P,S,T,Z
13.5	18.1	451	1455	27	145	0.82	P,S,T,Z
13.5	18.1	453	1455	27	145	0.82	P,S,T,Z
13.5	18.1	454	1455	27	145	0.82	P,S,T,Z
13.5	18.1	455	1455	27	145	0.82	P,S,T,Z
13.5	18.1	456	1455	27	145	0.82	P,S,T,Z

SH



WS004074A

Table 16: 400 V, 50 Hz, 3-phase

Rated power, kW	Rated power, hp	Curve/ Impeller No	Revolutions per minute, rpm	Rated current, A	Starting current, A	Power factor, cos φ	Installation
11	14.8	273	2905	19	139	0.94	P,S,T,Z
11	14.8	274	2905	19	139	0.94	P,S,T,Z
11	14.8	275	2905	19	139	0.94	P,S,T,Z
11	14.8	276	2905	19	139	0.94	P,S,T,Z
15	20	270	2910	27	213	0.89	P,S,T,Z
15	20	272	2910	27	213	0.89	P,S,T,Z
15	20	273	2910	27	213	0.89	P,S,T,Z
15	20	274	2910	27	213	0.89	P,S,T,Z
15	20	275	2910	27	213	0.89	P,S,T,Z

Rated power, kW	Rated power, hp	Curve/ Impeller No	Revolutions per minute, rpm	Rated current, A	Starting current, A	Power factor, cos φ	Installation
15	20	276	2910	27	213	0.89	P,S,T,Z

Motor rating and performance curves 3153.660/.670

These are examples of motor rating and curves. For more information, please contact your local sales and service representative.

Star-delta starting current is 1/3 of Direct on-line starting current.

MT

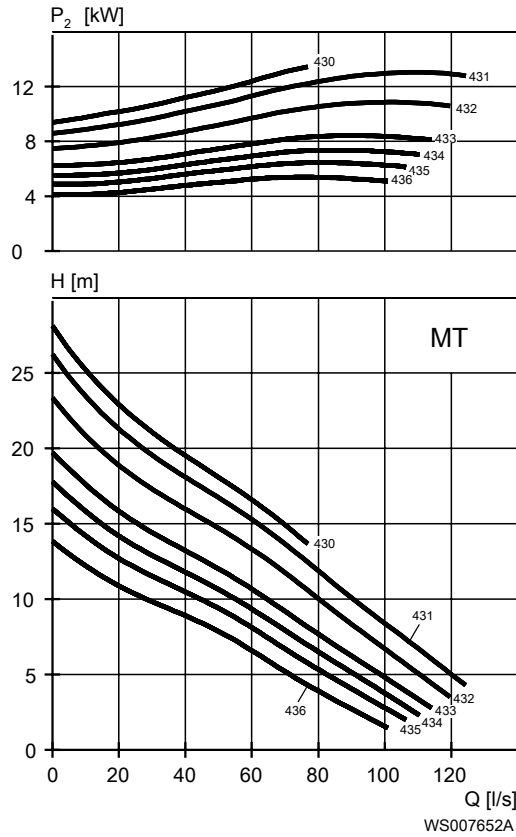

Table 17: 400 V, 50 Hz, 3-phase

Rated power, kW	Rated power, hp	Curve/ Impeller No	Revolutions per minute, rpm	Rated Current, A	Start current, A	Power Factor, cos φ	Installation
7.5	10.1	434	1465	16	107	0.76	P,S
7.5	10.1	435	1465	16	107	0.76	P,S
7.5	10.1	436	1465	16	107	0.76	P,S
9	12.1	433	1460	19	107	0.8	P,S
9	12.1	434	1460	19	107	0.8	P,S
9	12.1	435	1460	19	107	0.8	P,S
9	12.1	436	1460	19	107	0.8	P,S
13.5	18.1	430	1455	27	145	0.82	P,S
13.5	18.1	431	1455	27	145	0.82	P,S
13.5	18.1	432	1455	27	145	0.82	P,S
13.5	18.1	433	1455	27	145	0.82	P,S

Rated power, kW	Rated power, hp	Curve/ Impeller No	Revolutions per minute, rpm	Rated Current, A	Start current, A	Power Factor, cos φ	Installation
13.5	18.1	434	1455	27	145	0.82	P,S
13.5	18.1	435	1455	27	145	0.82	P,S
13.5	18.1	436	1455	27	145	0.82	P,S

HT

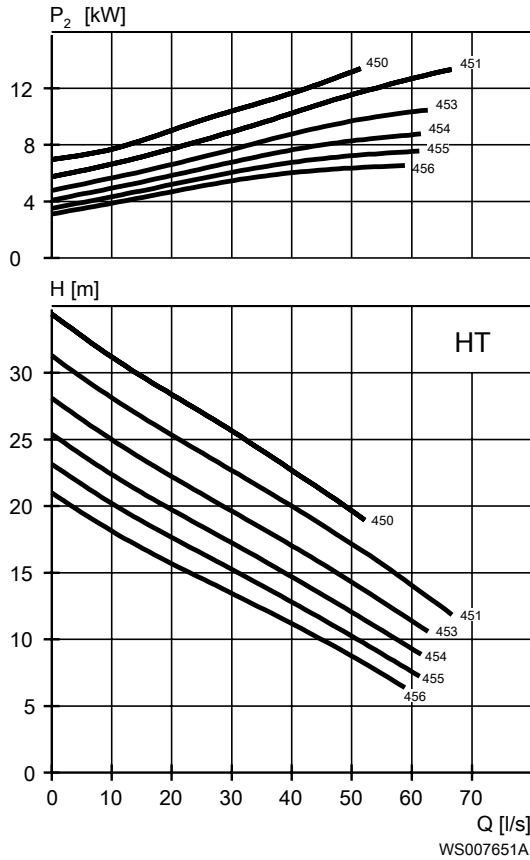

Table 18: 400 V, 50 Hz, 3-phase

Rated power, kW	Rated power, hp	Curve/ Impeller No	Revolutions per minute, rpm	Rated Current, A	Start current, A	Power Factor, cos φ	Installation
7.5	10.1	456	1465	16	107	0.76	P,S
9	12.1	454	1460	19	107	0.8	P,S
9	12.1	455	1460	19	107	0.8	P,S
9	12.1	456	1460	19	107	0.8	P,S
13.5	18.1	450	1455	27	145	0.82	P,S
13.5	18.1	451	1455	27	145	0.82	P,S
13.5	18.1	453	1455	27	145	0.82	P,S
13.5	18.1	454	1455	27	145	0.82	P,S
13.5	18.1	455	1455	27	145	0.82	P,S
13.5	18.1	456	1455	27	145	0.82	P,S

N-pump, Premium Efficiency Motor (IE3)

Product description



Usage

A submersible pump for efficient pumping of clean water, surface water, and wastewater containing solids or long-fibered material. The pump is designed for sustained high efficiency. For abrasive media, Hard-Iron™ is required. Stainless steel N-impeller is available as an option.

Denomination

Type	Non-explosion proof version	Explosion proof version	Pressure class	Installation types
Cast iron	3153.800	3153.810	LT – Low head MT – Medium head HT – High head SH – Super head	P, S, T, Z
Hard-Iron™	3153.820	3153.830	LT – Low head MT – Medium head HT – High head SH – Super head	P, S, T, Z
Stainless steel	3153.860	3153.870	MT – Medium head HT – High head	P, S

The pump can be used in the following installations:

- P Semi permanent, wet well arrangement with pump installed on two guide bars with automatic connection to discharge.
- S Portable semi permanent, wet well arrangement with hose coupling or flange for connection to discharge pipeline.
- T Vertical permanent, dry well arrangement with flange connection to suction and discharge piping.
- Z Horizontal permanent, dry well arrangement with flange connection to suction and discharge piping.

Application limits

Feature	Description
Liquid temperature	Maximum 40°C (104°F)
Depth of immersion	Maximum 20 m (65 ft)
pH of the pumped liquid	5.5 - 14
Liquid density	Maximum 1100 kg/m ³

Motor data

Feature	Description
Motor type	Line started permanent magnet motor (LSPM) Squirrel-cage induction motor
Frequency	50 Hz
Power supply	3-phase
Starting method	<ul style="list-style-type: none"> • Direct on-line • Star-delta • Variable Frequency Drive (VFD)
Number of starts per hour	Maximum 30
Code compliance	IEC 60034-1
Voltage variation	<ul style="list-style-type: none"> • Continuously running: Maximum ±5% • Intermittent running: Maximum ±10%
Voltage imbalance between phases	Maximum 2%
Stator insulation class	H (180°C, 356°F)

Cables

Application	Type
Direct-on-line start or Y/D start with two cables	Flygt SUBCAB® - a heavy duty 4 cores motor power cable with two twisted pair screened control cores. Conductor insulation rating of 90°C, which allows for increased current. Superior mechanical strength and high abrasion and tear resistant. Chemical resistant within pH 3-10 and ozone, oil, and flame resistant. Used up to 70°C water temperature. Cables < 10 mm ² with unscreened control cores.
Y/D start	Flygt SUBCAB® - a heavy duty 7 cores motor power cable with two twisted pair screened control cores. Conductor insulation rating of 90°C, which allows for increased current. Superior mechanical strength and high abrasion and tear resistant. Chemical resistant within pH 3-10 and ozone, oil, and flame resistant. Used up to 70°C water temperature. Cables < 7G6 mm ² with unscreened control cores.
Variable Frequency drive	Screened Flygt SUBCAB® - a heavy duty 4 screened cores motor power cable with four twisted pair screened control cores. Conductor insulation rating of 90°C, which allows for increased current. Superior mechanical strength and high abrasion and tear resistant. Chemical resistant within pH 3-10 and ozone, oil, and flame resistant. Used up to 70°C water temperature.

Monitoring equipment

- Thermal contacts opening temperature 140° C (284° F)
- Leakage sensor in the inspection chamber (FLS 10)

Materials

Table 19: Major parts except mechanical seals

Denomination	Material	ASTM	EN
Major castings	Cast iron, gray	35B	GJL-250
Pump housing	Cast iron, gray	35B	GJL-250
Impeller, alternative 1	Cast iron, gray	35B	GJL-250
Impeller, alternative 2	Cast iron, Hard-Iron™	A 532 IIIA	GJN-HB555(XCR23)
Impeller, alternative 3	Stainless steel, Duplex	CD-4MCuN	10283:2010 -1.4474
Insert ring, alternative 1	Cast iron, gray	35B	GJL-250
Insert ring, alternative 2	Cast iron, Hard-Iron™	A 532 IIIA	GJN-HB555(XCR23)
Cooling jacket, inner	Aluminum	AA 1050A	AW-1050A
Cooling jacket, outer, alternative 1	Steel	GR65	S235JRG2
Cooling jacket, outer, alternative 2	Stainless steel	AISI 316L	1.4404,1.4432, ...
Lifting handle	Stainless steel	AISI 316L	1.4404,1.4432, ...
Shaft	Stainless steel	AISI 431	1.4057+QT800
Screws and nuts	Stainless steel, A4	AISI 316L, 316, 316Ti	1.4401,1.4404, ...
O-rings, alternative 1	Nitrile rubber (NBR) 70° IRH	-	-
O-rings, alternative 2	Fluorinated rubber (FPM) 70° IRH	-	-
Glycol	Heat transfer fluid based on monopropylene glycol.	-	-

Table 20: Mechanical seals

Alternative	Inner seal	Outer seal
1	Corrosion resistant cemented carbide/ Corrosion resistant cemented carbide	Corrosion resistant cemented carbide/ Corrosion resistant cemented carbide
2	Corrosion resistant cemented carbide/ Corrosion resistant cemented carbide	Silicon carbide/ Silicon carbide

Surface treatment

Priming	Finish
Painted with a primer, see internal standard M0700.00.0002	Navy gray color NCS 5804-B07G. Two-component high-solid top coating, see internal standard M0700.00.0004 for standard painting and M0700.00.0008 for special painting.

Options

- Sensors: Thermistor, FLS, PT 100, VIS 10
- Surface treatment (Epoxy)
- Zinc anodes
- Other cables

Accessories

Discharge connections, adapters, hose connections, and other mechanical accessories.
Electrical accessories such as pump controller, control panels, starters, monitoring relays, cables.

Motor rating and performance curves 3153.800/.810/.820/.830

These are examples of motor rating and curves. For more information, please contact your local sales and service representative.

Star-delta starting current is 1/3 of Direct on-line starting current.

LT

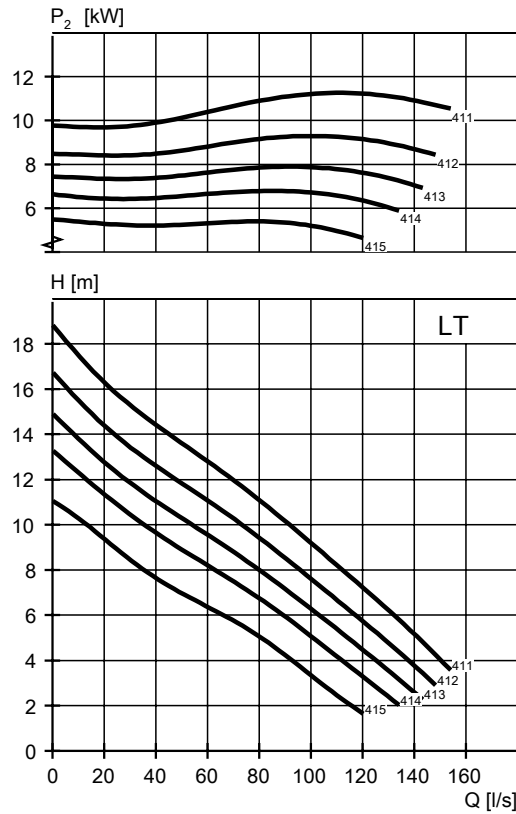

WS004090A

Table 21: 400 V, 50 Hz, 3-phase

Rated power, kW	Rated power, hp	Curve/ Impeller No	Revolutions per minute, rpm	Rated Current, A	Start current, A	Power Factor, cos φ	Installation
8.5	11.4	413	1500	14	107	0.98	P,S,T,Z
8.5	11.4	414	1500	14	107	0.98	P,S,T,Z
8.5	11.4	415	1500	14	107	0.98	P,S,T,Z
10	13.4	412	1500	16	107	0.98	P,S,T,Z
10	13.4	413	1500	16	107	0.98	P,S,T,Z
10	13.4	414	1500	16	107	0.98	P,S,T,Z
10	13.4	415	1500	16	107	0.98	P,S,T,Z
12.5	16.8	411	1500	21	145	0.95	P,S,T,Z
12.5	16.8	412	1500	21	145	0.95	P,S,T,Z
12.5	16.8	413	1500	21	145	0.95	P,S,T,Z
12.5	16.8	414	1500	21	145	0.95	P,S,T,Z
12.5	16.8	415	1500	21	145	0.95	P,S,T,Z

MT

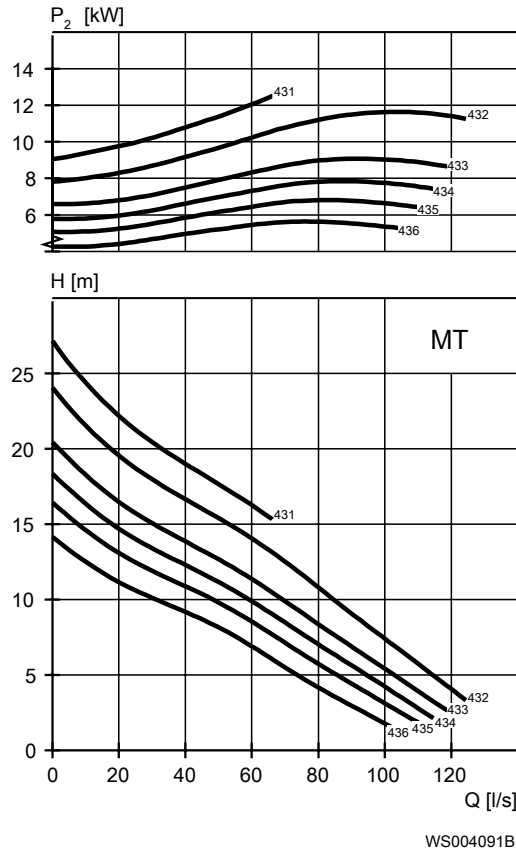

Table 22: 400 V, 50 Hz, 3-phase

Rated power, kW	Rated power, hp	Curve/ Impeller No	Revolutions per minute, rpm	Rated Current, A	Start current, A	Power Factor, cos φ	Installation
8.5	11.4	433	1500	14	107	0.98	P,S,T,Z
8.5	11.4	434	1500	14	107	0.98	P,S,T,Z
8.5	11.4	435	1500	14	107	0.98	P,S,T,Z
8.5	11.4	436	1500	14	107	0.98	P,S,T,Z
10	13.4	433	1500	16	107	0.98	P,S,T,Z
10	13.4	434	1500	16	107	0.98	P,S,T,Z
10	13.4	435	1500	16	107	0.98	P,S,T,Z
10	13.4	436	1500	16	107	0.98	P,S,T,Z
12.5	16.8	431	1500	21	145	0.95	P,S,T,Z
12.5	16.8	432	1500	21	145	0.95	P,S,T,Z
12.5	16.8	433	1500	21	145	0.95	P,S,T,Z
12.5	16.8	434	1500	21	145	0.95	P,S,T,Z
12.5	16.8	435	1500	21	145	0.95	P,S,T,Z
12.5	16.8	436	1500	21	145	0.95	P,S,T,Z

HT

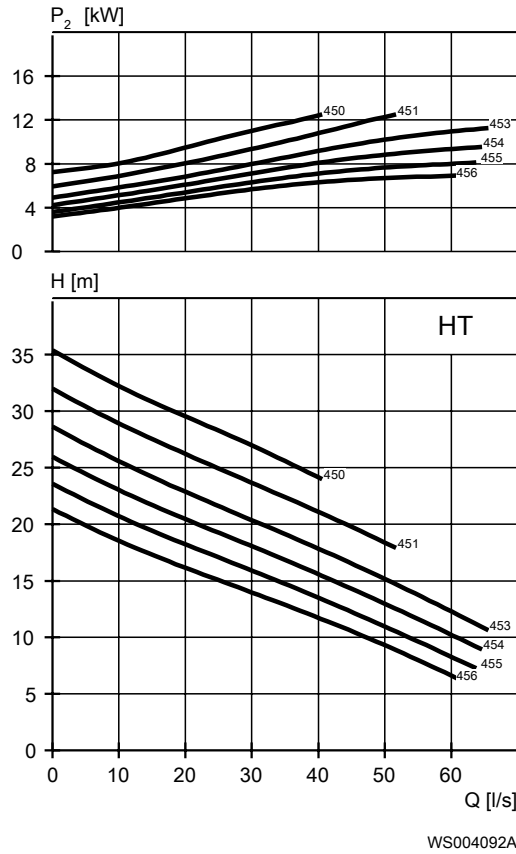
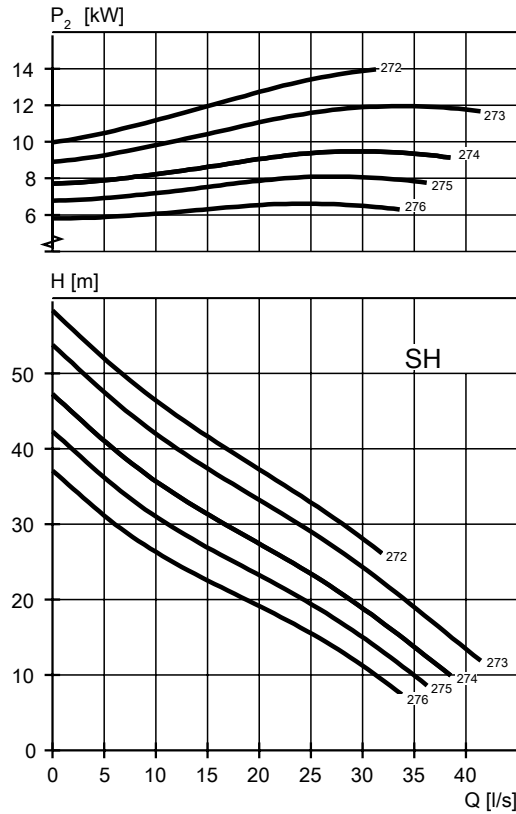

Table 23: 400 V, 50 Hz, 3-phase

Rated power, kW	Rated power, hp	Curve/ Impeller No	Revolutions per minute, rpm	Rated Current, A	Start current, A	Power Factor, cos φ	Installation
8.5	11.4	451	1500	14	107	0.98	P,S,T,Z
8.5	11.4	453	1500	14	107	0.98	P,S,T,Z
8.5	11.4	454	1500	14	107	0.98	P,S,T,Z
8.5	11.4	455	1500	14	107	0.98	P,S,T,Z
8.5	11.4	456	1500	14	107	0.98	P,S,T,Z
10	13.4	450	1500	16	107	0.98	P,S,T,Z
10	13.4	451	1500	16	107	0.98	P,S,T,Z
10	13.4	453	1500	16	107	0.98	P,S,T,Z
10	13.4	454	1500	16	107	0.98	P,S,T,Z
10	13.4	455	1500	16	107	0.98	P,S,T,Z
10	13.4	456	1500	16	107	0.98	P,S,T,Z
12.5	16.8	450	1500	21	145	0.95	P,S,T,Z
12.5	16.8	451	1500	21	145	0.95	P,S,T,Z
12.5	16.8	453	1500	21	145	0.95	P,S,T,Z
12.5	16.8	454	1500	21	145	0.95	P,S,T,Z
12.5	16.8	455	1500	21	145	0.95	P,S,T,Z
12.5	16.8	456	1500	21	145	0.95	P,S,T,Z

SH



WS004093B

Table 24: 400 V, 50 Hz, 3-phase

Rated power, kW	Rated power, hp	Curve/ Impeller No	Revolutions per minute, rpm	Rated Current, A	Start current, A	Power Factor, cos φ	Installation
11	14.8	273	2915	19	147	0.93	P,S,T,Z
11	14.8	274	2915	19	147	0.93	P,S,T,Z
11	14.8	275	2915	19	147	0.93	P,S,T,Z
11	14.8	276	2915	19	147	0.93	P,S,T,Z
14	18.8	272	2925	25	214	0.88	P,S,T,Z
14	18.8	273	2925	25	214	0.88	P,S,T,Z
14	18.8	274	2925	25	214	0.88	P,S,T,Z
14	18.8	275	2925	25	214	0.88	P,S,T,Z
14	18.8	276	2925	25	214	0.88	P,S,T,Z

Motor rating and performance curves 3153.860/.870

These are examples of motor rating and curves. For more information, please contact your local sales and service representative.

Star-delta starting current is 1/3 of Direct on-line starting current.

MT

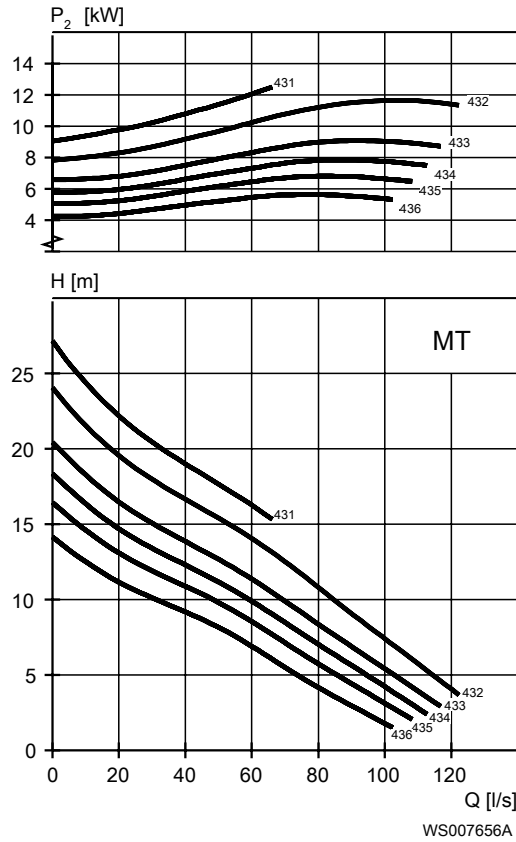

Table 25: 400 V, 50 Hz, 3-phase

Rated power, kW	Rated power, hp	Curve/ Impeller No	Revolutions per minute, rpm	Rated Current, A	Start current, A	Power Factor, cos φ	Installation
8.5	11.4	434	1500	14	107	0.98	P,S
8.5	11.4	435	1500	14	107	0.98	P,S
8.5	11.4	436	1500	14	107	0.98	P,S
10	13.4	433	1500	16	107	0.98	P,S
10	13.4	434	1500	16	107	0.98	P,S
10	13.4	435	1500	16	107	0.98	P,S
10	13.4	436	1500	16	107	0.98	P,S
12.5	16.8	431	1500	21	145	0.95	P,S
12.5	16.8	432	1500	21	145	0.95	P,S
12.5	16.8	433	1500	21	145	0.95	P,S
12.5	16.8	434	1500	21	145	0.95	P,S
12.5	16.8	435	1500	21	145	0.95	P,S
12.5	16.8	436	1500	21	145	0.95	P,S

HT

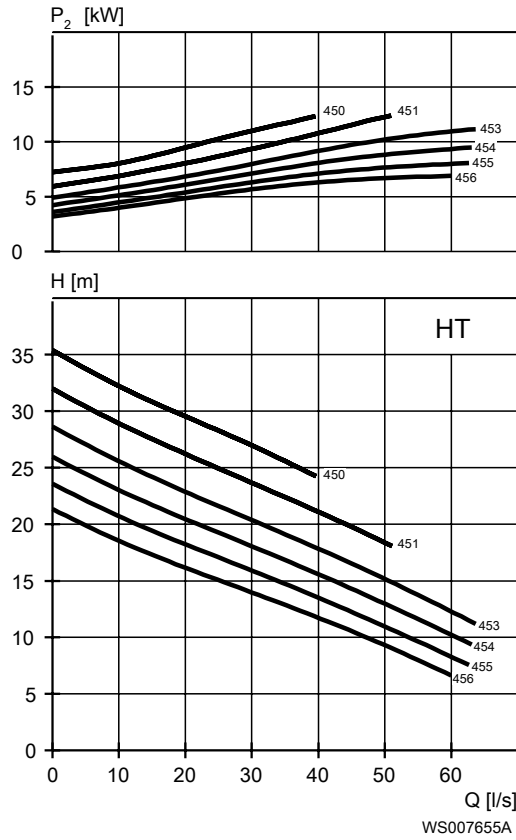

Table 26: 400 V, 50 Hz, 3-phase

Rated power, kW	Rated power, hp	Curve/ Impeller No	Revolutions per minute, rpm	Rated Current, A	Start current, A	Power Factor, cos φ	Installation
8.5	11.4	455	1500	14	107	0.98	P,S
8.5	11.4	456	1500	14	107	0.98	P,S
10	13.4	454	1500	16	107	0.98	P,S
10	13.4	455	1500	16	107	0.98	P,S
10	13.4	456	1500	16	107	0.98	P,S
12.5	16.8	450	1500	21	145	0.95	P,S
12.5	16.8	451	1500	21	145	0.95	P,S
12.5	16.8	453	1500	21	145	0.95	P,S
12.5	16.8	454	1500	21	145	0.95	P,S
12.5	16.8	455	1500	21	145	0.95	P,S
12.5	16.8	456	1500	21	145	0.95	P,S

Dimensions and Weight

Drawings

All drawings are available as Acrobat documents (.pdf) and AutoCad drawings (.dwg). Contact your local sales and service representative for more information.

All dimensions are in mm.

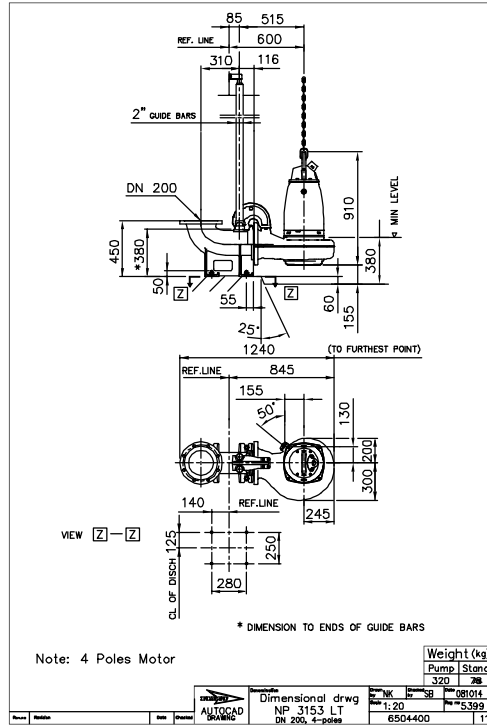

Figure 13: LT, P-installation

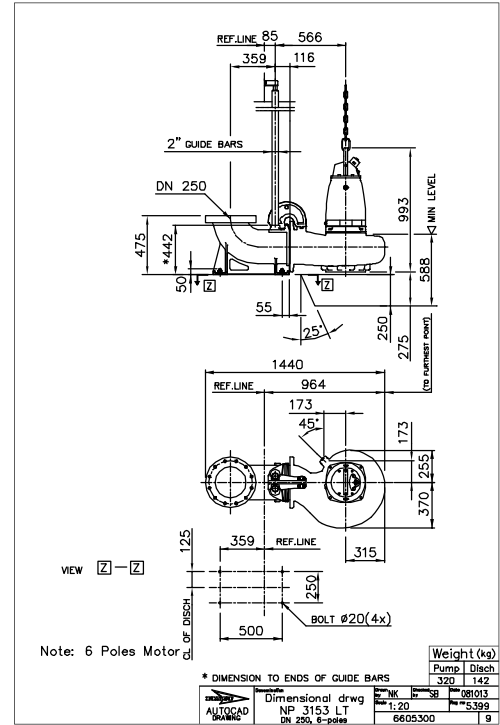

Figure 14: LT, P-installation

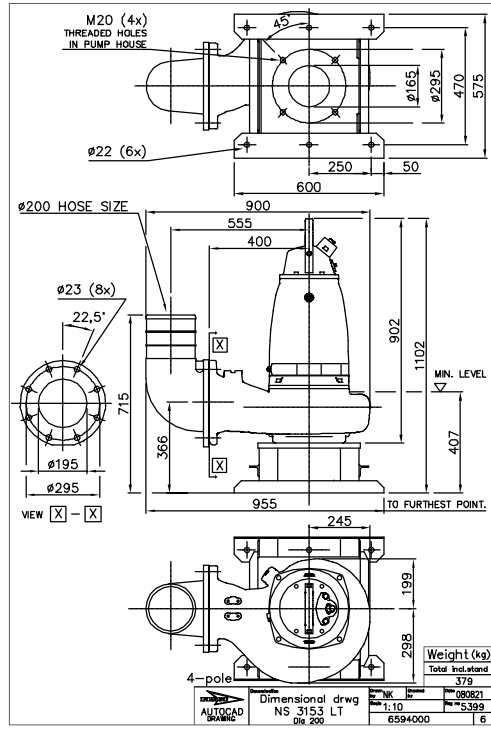

Figure 15: LT, S-installation

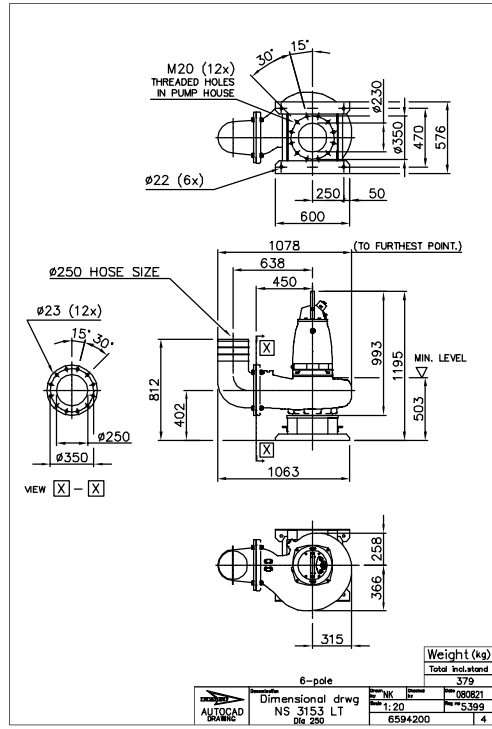

Figure 16: LT, S-installation

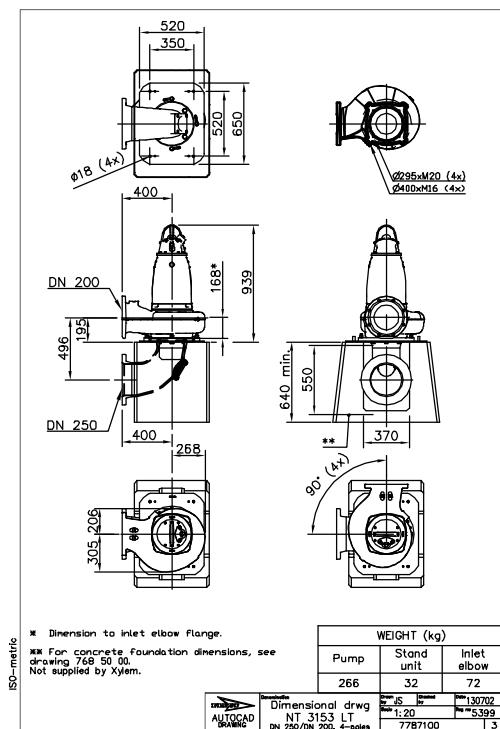

Figure 17: LT, T-installation

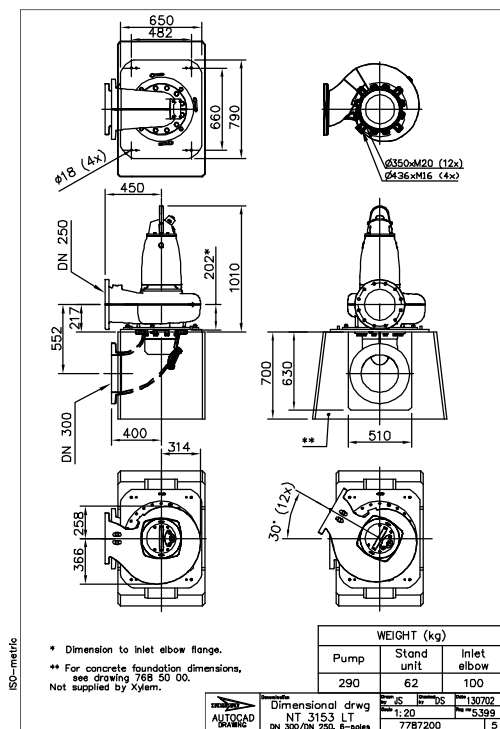

Figure 18: LT, T-installation

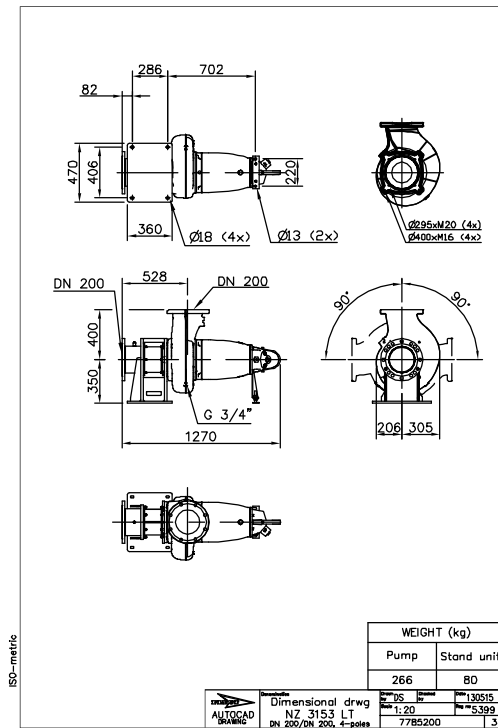

Figure 19: LT, Z-installation

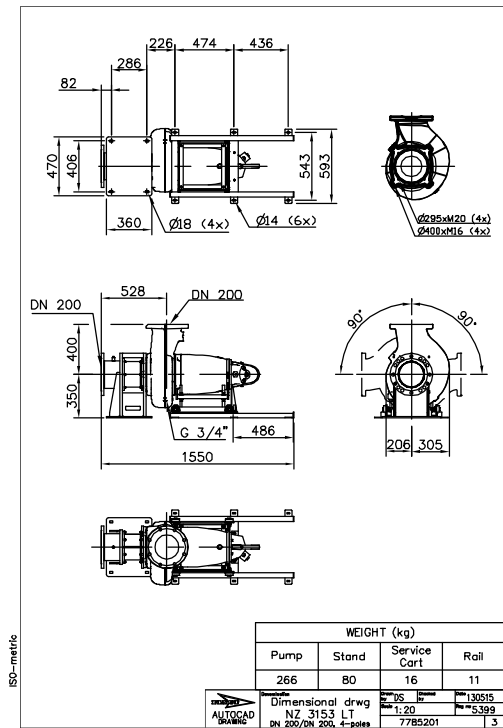

Figure 20: LT, Z-installation

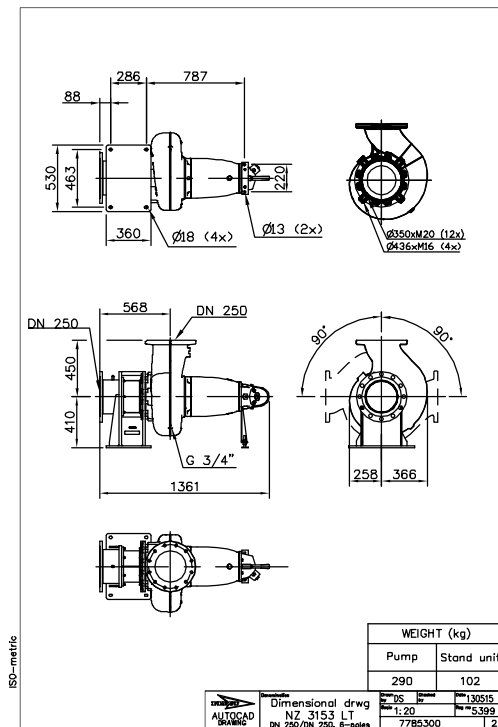

Figure 21: LT, Z-installation

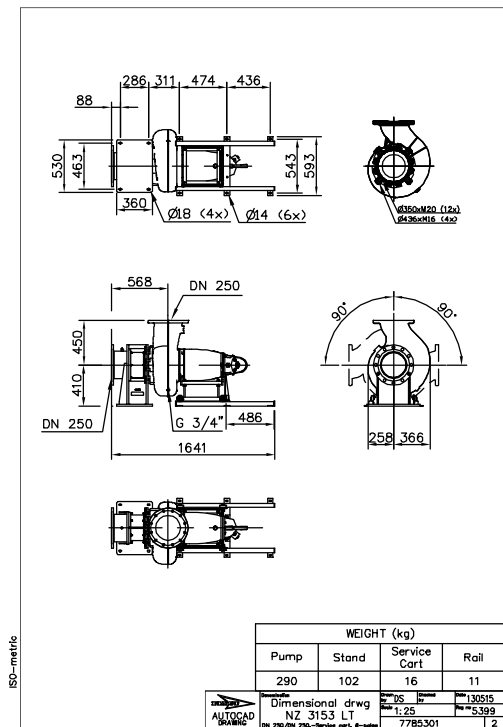

Figure 22: LT, Z-installation

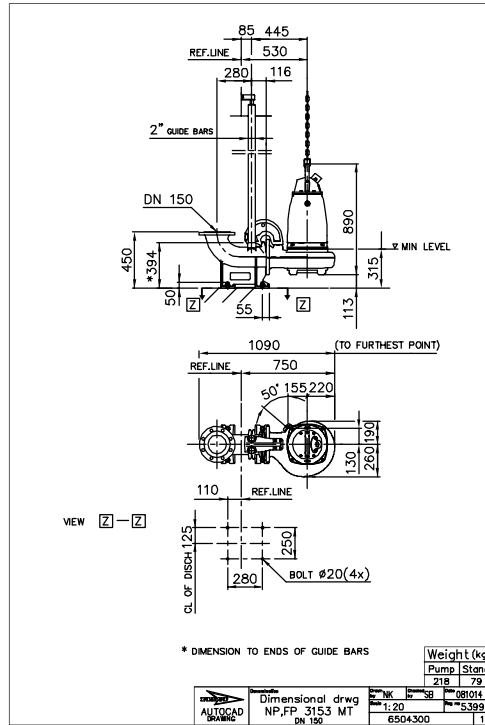

Figure 23: MT, P-installation

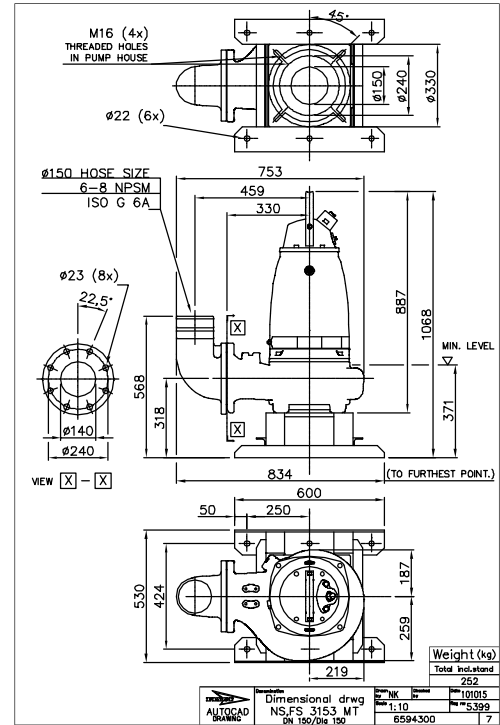

Figure 24: MT, S-installation

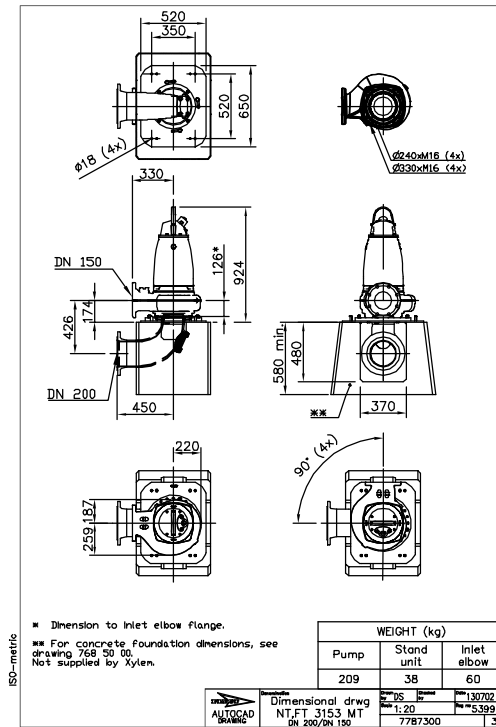

Figure 25: MT, T-installation

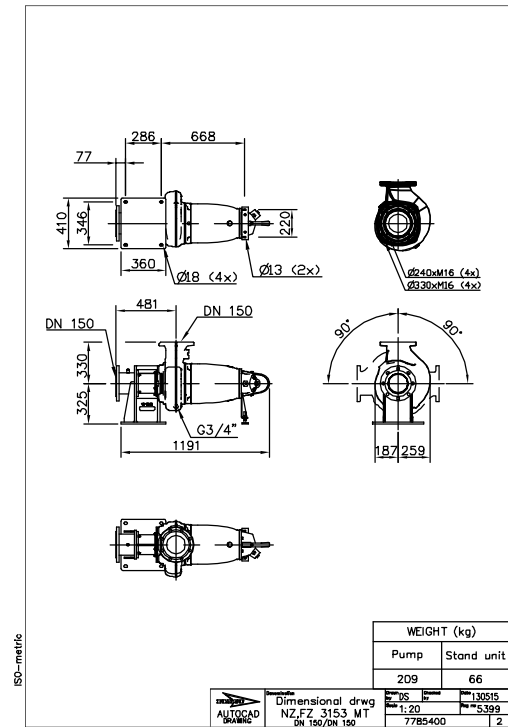

Figure 26: MT, Z-installation

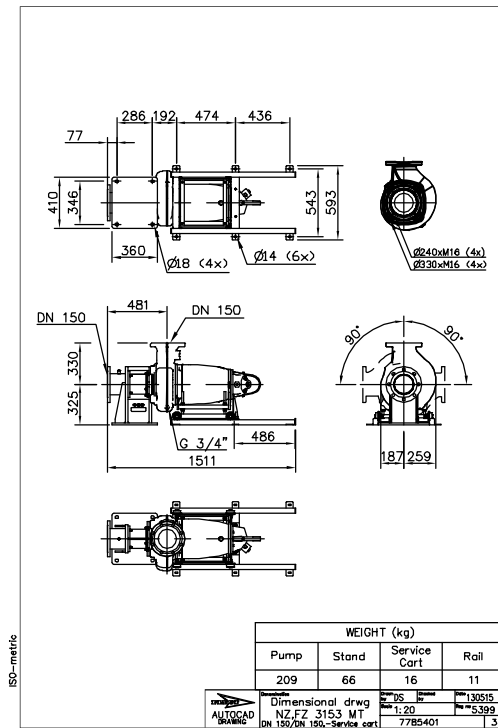

Figure 27: MT, Z-installation

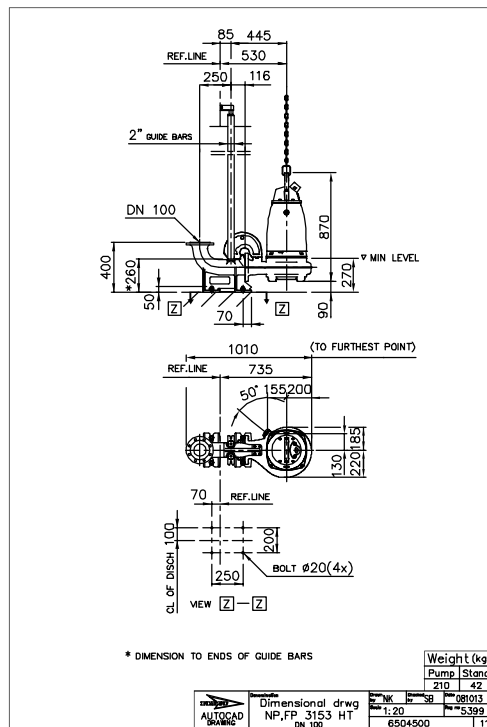

Figure 28: HT, P-installation

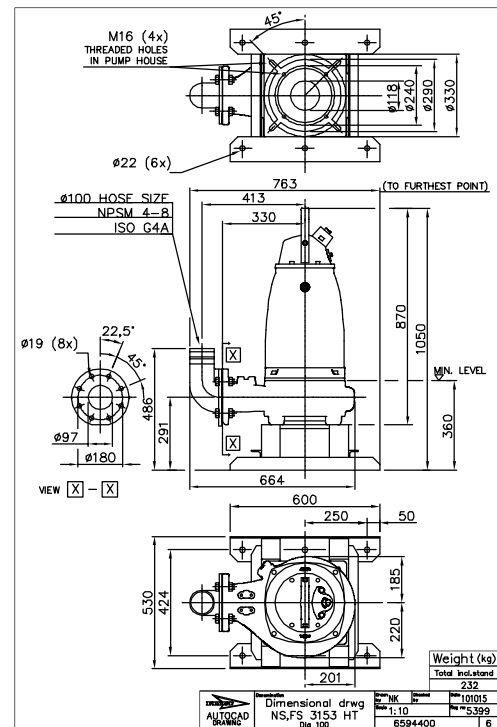

Figure 29: HT, S-installation

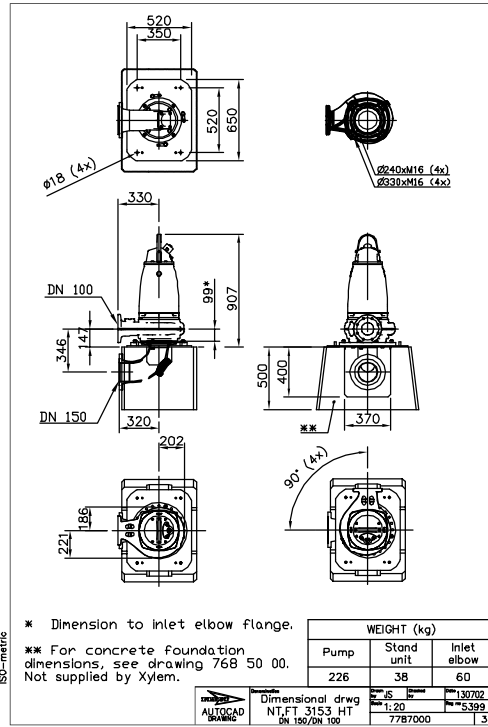

Figure 30: HT, T-installation

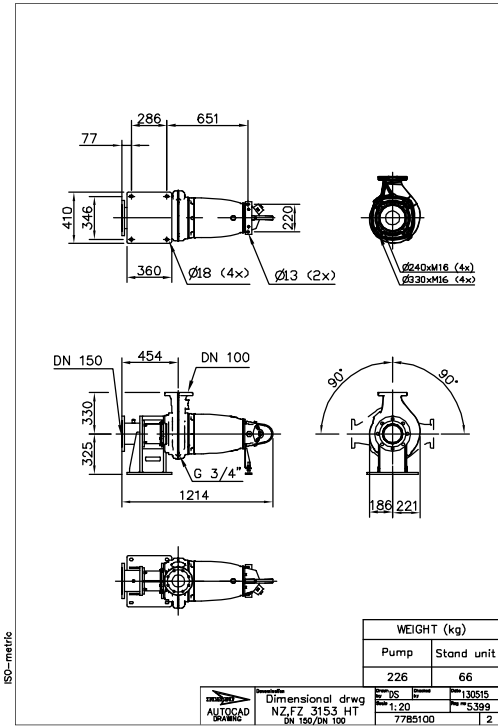

Figure 31: HT, Z-installation

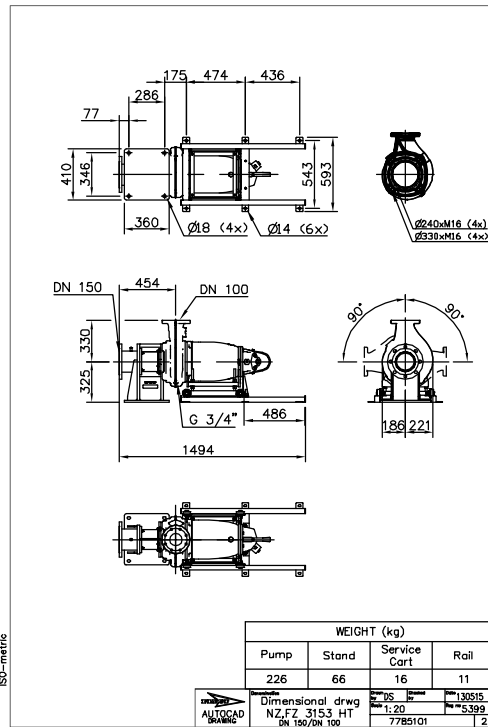

Figure 32: HT, Z-installation

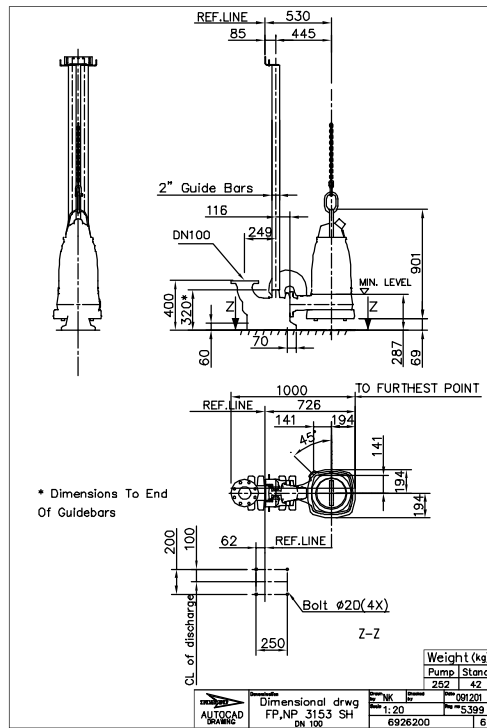

Figure 33: SH, P-installation

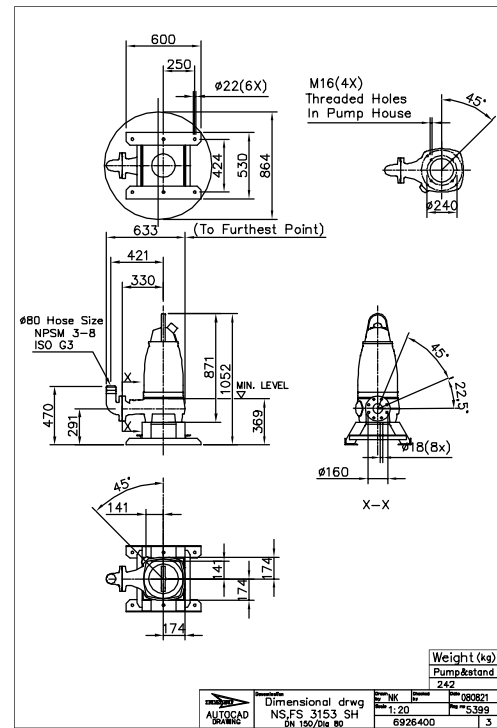

Figure 34: SH, S-installation

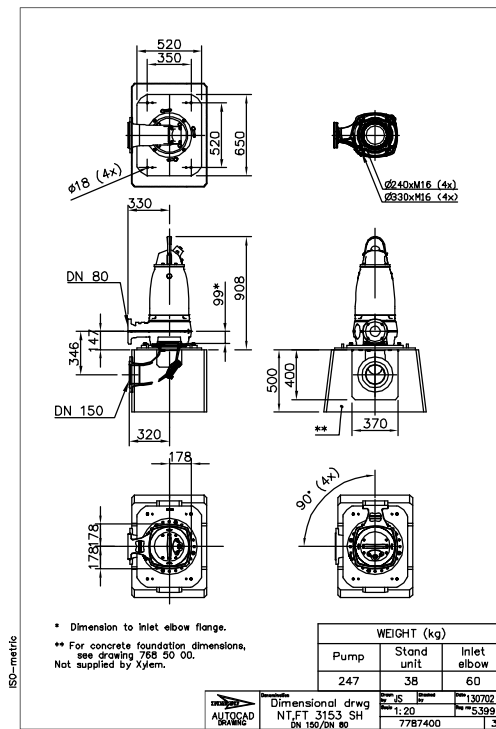

Figure 35: SH, T-installation

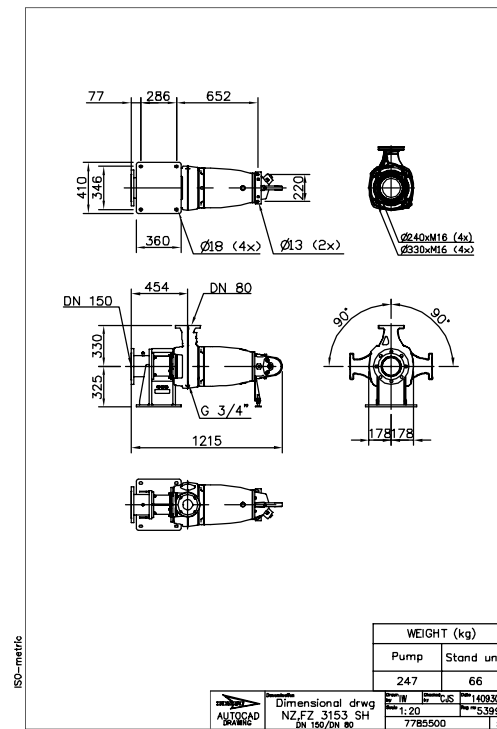

Figure 36: SH, Z-installation

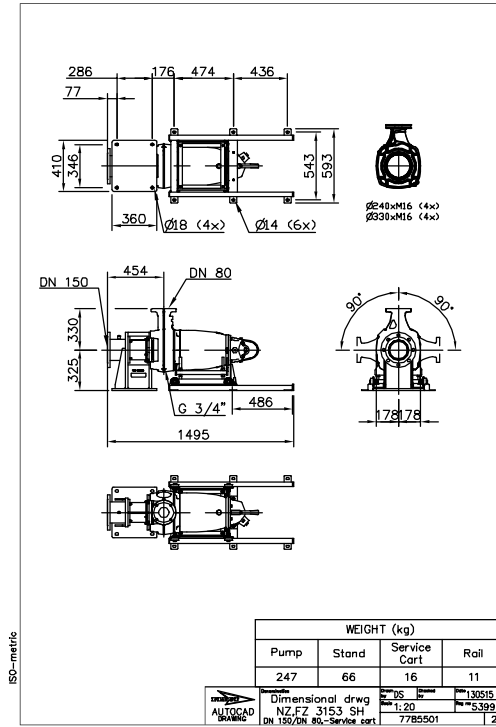

Figure 37: SH, Z-installation