



Flygt 2740

Table of Contents

Introduction.....	2
Specially approved products.....	2
Product Description.....	3
The data plate.....	3
Product denomination.....	3
Exploded Views.....	5
2740.280.....	5
2740.390.....	6
Spare Parts.....	7
2740.280.....	7
2740.390.....	10

Introduction

Purpose of this manual

The purpose of this manual is to provide necessary information on spare parts and accessories order.

Disclaimer

Always use genuine Flygt parts. The use of other spare parts or accessories can invalidate any claims for warranty or compensation. Xylem does not take any responsibility for damages that are caused by the use of non-original parts. For more information, contact your local sales and service representative.

Data for ordering spare parts

The following information is needed for spare part orders:

- Serial number of the product
- Part number
- Quantity of bulk material, see * in tables

Specially approved products

Qualification of personnel

Only Xylem or Xylem-authorized service personnel may undertake repair work on Ex-approved products.

Dimensional accuracy inspection

Spare parts marked with (Ex) after the part number are subject to dimensional accuracy inspection.

Product Description

Products included

Pump model	Approvals
2740.280 2740.390	Standard European Norm (EN) <ul style="list-style-type: none"> • ATEX Directive • EN 1127-1, EN 60079-0, EN 60079-15 •  II 3G Ex nA/nC c IICT1...T4

The data plate

The data plate is a metal label that is located on the main body of the products. The data plate lists key product specifications. Specially approved products also have an approval plate.

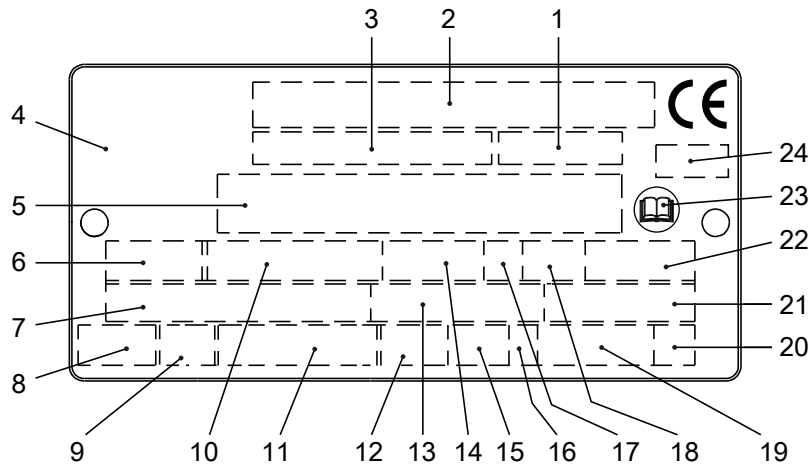

WS006257A

1. Curve code or Propeller code
2. Serial number, see [Product denomination](#) (page 3)
3. Product number
4. Country of origin
5. Additional information
6. Phase; type of current; frequency
7. Rated voltage
8. Thermal protection
9. Thermal class
10. Rated shaft power
11. International standard
12. Degree of protection
13. Rated current
14. Rated speed
15. Maximum submergence
16. Direction of rotation: L=left, R=right
17. Duty class
18. Duty factor
19. Product weight
20. Locked rotor code letter
21. Power factor
22. Maximum ambient temperature
23. Read installation manual
24. Notified body, only for EN-approved Ex products

Figure 1: The data plate

Product denomination

Reading instruction

In this section, code characters are illustrated accordingly:

X = letter

Y = digit

The different types of codes are marked up with a, b and c. Code parameters are marked up with numbers.

Codes and parameters

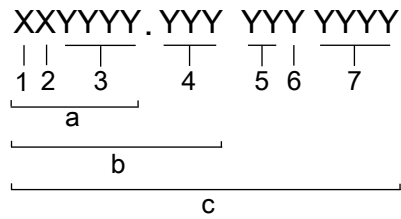

WS006265B

Type of Callout	Number	Indication
Type of code	a	Sales denomination
	b	Product code
	c	Serial number
Parameter	1	Hydraulic end
	2	Type of installation
	3	Sales code
	4	Version
	5	Production year
	6	Production cycle
	7	Running number

Exploded Views

2740.280

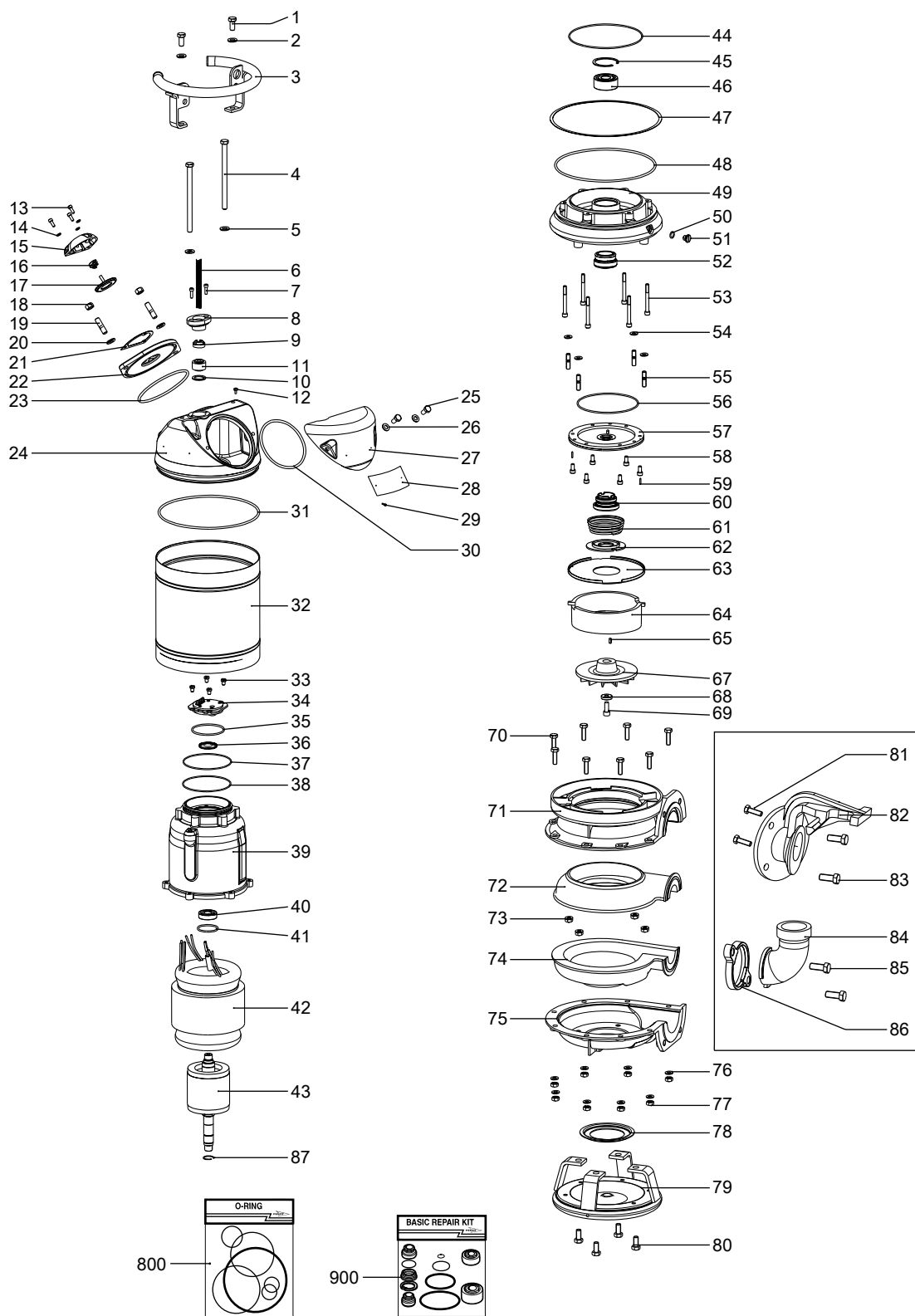

20214A_2730/2740.280_expl_view

2740.390

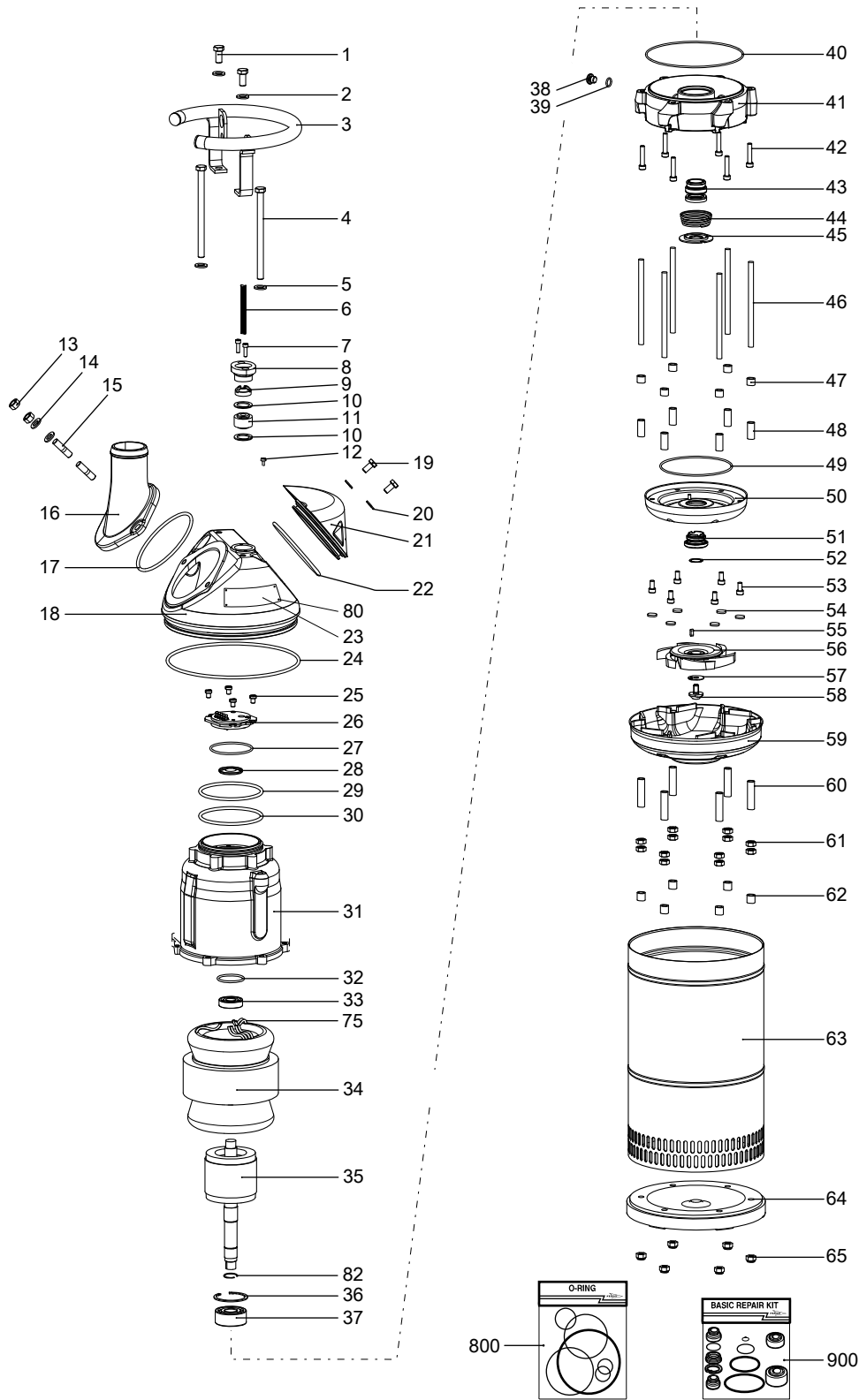

20215A_2740_390_HT_MT_expl_view

Spare Parts

2740.280

Pos. No	Part. No	Denomination	Qty/ Version
			280
1	81 49 05	Hexagon head screw M12X25-A4-70	2
2	82 35 77	Plain washer A4-A170	2
3	680 81 00	Handle	1
4	81 46 75	Hexagon head screw	2
5	82 35 77	Plain washer A4-A170	2
6	94 20 59	Motor cable subcab SUBCAB 4G2,5+2x1,5 17 - 18mm	*
6	94 20 60	Motor cable subcab SUBCAB 4G4+2x1,5 20 - 22mm	*
6	94 21 06	Motor cable SUBCAB 10AWG/3-2-1-GC 20,30 - 22,30mm	*
7	83 02 77	Hex.socket hd screw M6X20-A4-70	2
8	640 89 04	Entrance flange Cable entry (16)-18mm Cable entry (18)-20mm Cable entry (20)-22mm	1
8	673 30 00	Entrance flange ISO G1 Cable entry for metal hose (16)-18mm Cable entry for metal hose (18)-20mm Cable entry for metal hose (20)-22mm	1
8	640 89 02	Entrance flange Cable entry (22)-26mm	1
9	678 58 18	Cable clip (16)-18 MM	1
9	678 58 22	Cable clip (20)-22 MM	1
9	678 58 24	Cable clip (22)-24 MM	1
9	678 58 26	Cable clip (24)-26 MM	1
9	678 58 20	Cable clip (18)-20 MM	1
10	82 42 39	Plain washer (16)-18 MM	1
10	82 42 41	Plain washer (20)-22 MM	1
10	82 40 62	Plain washer (24)-26 MM	1
10	82 42 40	Plain washer (18)-20 MM	1
11	84 17 93	Seal sleeve (16)-18 MM	1
11	84 17 95	Seal sleeve (20)-22 MM	1
11	84 17 96	Seal sleeve (22)-24MM	1
11	84 17 97	Seal sleeve (24)-26MM	1
11	84 15 89	Seal sleeve (16)-18 MM	1
11	84 15 90	Seal sleeve (18)-20 MM	1
11	84 15 91	Seal sleeve (20)-22 MM	1
12	81 73 72	Slotted head screw M6X10-A4-70	1
13	83 02 75	Hex.socket hd screw M6X16-A4-70	3
14	82 48 89	Spring washer DIN 127-B-6-A4	3
15	686 72 01	Special washer	1
16	312 62 01	Compression spring	1

Pos. No	Part. No	Denomination	Qty/ Version
			280
17	710 51 00	Air release valve	1
18	82 23 35	Hexagon nut M12-A4-70	2
19	84 94 87	Stud	2
20	82 35 77	Plain washer A4-A170	2
21	403 49 00	Gasket	1
22	686 73 00	Special washer	1
23	82 81 04	O-ring 139.3X5.7 FPM	1
24	679 07 00	Cover	1
25	81 48 79	Hexagon head screw M10X20-A4-70	2
26	82 35 76	Plain washer 10-A4-170	2
27	679 08 00	Connection cover	1
28	630 68 02	Data plate	1
29	82 21 73	Drive screw 4X5-A4	2
30	82 81 83	O-ring 129.3X5.7 FPM	1
31	82 80 87	O-ring 249.3X5.7 FPM	1
32	682 11 00	Outer casing	1
33	81 44 02	Slotted head screw	4
34	710 90 01	Connection term boar	1
35	80 94 49	O-ring 74.61X3.53 FPM	1
36	710 61 00	Bearing cover	1
37	80 94 44	O-ring 117.5X5.34 FPM	1
38	82 81 59	O-ring 119.5X3 FPM	1
39	713 89 00	Stator housing	1
40	83 32 35	Ball bearing	1
41	80 94 48	O-ring 47.2X3.53 FPM	1
42	711 94 05	Stator 19-10-2b	6-leads 50 Hz 230V D 380V-415V Y P2=6,30kW
42	711 94 09	Stator 19-10-2b	6-leads 50 Hz 500V-550V D P2=6,30kW
42	711 94 14	Stator 19-10-2b	9-leads 60 Hz 440V-460V YSER 220V-230V Y// P2=6,70kW/9hp
42	711 94 16	Stator 19-10-2b	6-leads 60 Hz 575V-600V D P2=6,70kW/9hp
43	711 95 01	Shaft unit	1
44	82 71 42	O-ring 183.5X3 FPM	1
45	82 62 12	Retaining ring SGH 62	1
46	83 30 15	Ball bearing 3305A-2Z/C3VT113	1
47	283 94 00	Gasket	1
48	82 80 87	O-ring 249.3X5.7 FPM	1
49	710 10 00	Bearing holder	1
50	81 78 65	O-ring 12.37X2.62 FPM	1
51	710 45 01	Inspection screw	1
52	712 56 00	Mechanical seal	1
53	83 02 63	Hex.socket hd screw	6
54	709 71 00	Gasket	4
55	711 35 26	Stud	4
56	82 71 43	O-ring 156X3 FPM	1

Pos. No	Part. No	Denomination	Qty/ Version
			280
57	709 80 00	Oil housing bottom	1
58	83 02 97	Hex.socket hd screw M8X16-A4-70	6
59	80 36 00	Parallel pin	2
60	713 90 00	Mechanical seal	1
61	712 68 01	Compression spring	1
62	713 87 00	Plate	1
63	709 83 01	Guide plate	1
64	370 31 03	Wear ring	1
65	83 48 43	Parallel key 2306-5X5X14-A4-220HB	1
67	713 96 00	Impeller	243 HT 50Hz
67	713 96 01	Impeller	244 HT 60Hz
68	82 34 55	Plain washer	1
69	84 41 93	Hex.socket hd screw	1
70	81 46 74	Hexagon head screw M10X35-A4-70	8
71	284 92 63	Pump housing upper	1
72	370 35 00	Wear protection	1
73	82 23 33	Hexagon nut M10-A4-70	4
74	370 36 00	Wear protection	1
75	284 93 51	Pump housing lower	1
76	82 35 76	Plain washer 10-A4-170	8
77	82 23 33	Hexagon nut M10-A4-70	8
78	296 04 01	End washer	1
79	717 95 00	Stand	1
80	81 49 05	Hexagon head screw M12X25-A4-70	4
84	260 53 57	Discharge connection	DN 75 Hose
84	260 53 55	Discharge connection	DN 75 Thread : ISO G3A Outer Quick coupling: Storz
84	260 53 56	Discharge connection	DN 75 Thread : 3-8 NPT Outer
84	260 52 70	Discharge connection	DN 100 Hose
84	279 07 09	Discharge connection	DN 100 Thread : ISO G4A Outer Quick coupling: Storz diam=115 mm
84	279 07 10	Discharge connection	DN 100 Thread : NPT 4-8 Outer
85	81 41 81	Hexagon head screw M16X40-A4-70	2
86	284 91 80	Connection flange	1
87	82 63 86	Retaining ring 25-SPRING STEEL	1
88	83 20 10	Coupling part	DN 75 Thread : ISO G3A Outer Quick coupling: Storz
88	83 20 12	Coupling part	DN 100 Thread : ISO G4A Outer Quick coupling: Storz
88	83 20 11	Coupling part	DN 100 Thread : ISO G4A Outer Quick coupling: Storz diam=115 mm
89	83 41 83	Insulating sleeve 0.5-6 MM2	8-11
90	83 41 83	Insulating sleeve 0.5-6 MM2	5
91	83 41 84	Flat pin sleeve 0.75-1.5MM2	2
92	83 41 89	Flat pin sleeve 1-2.5MM2	6-9

Pos. No	Part. No	Denomination	Qty/ Version
			280
93	83 41 89	Flat pin sleeve 1-2.5MM2	2-5
93	84 92 75	Flat pin sleeve 2.5-6MM2	3-5
94	83 43 58	Cable lug INSUL.UL/CSA 1.04-2.6 MM2	1
94	83 42 96	Cable lug 2.5-6 MM2;M6	1-2
95	83 44 24	Closed-end splice 3-6(AWG 12-10) L=18	3
97	90 17 52	Oil ISO VG 32	*
98	94 05 86	Insulating hose D=12 MM	*
99	427 13 00	Marking tape	1
100	667 40 01	Sticker	2
101	766 71 00	Connection plate	1
102	81 73 72	Slotted head screw M6X10-A4-70	1
104	718 05 00	Sticker CUT HAZARD	1
105	340 71 00	Instruction plate	1
800	694 81 00	O-ring kits	1
801	783 47 00	Zinc anode kit	1
815	554 30 05	Starter	Starter 351 50/60 Hz 380V - 415 V Current range: 9 - 14 A supervision Phase sequence indicator Supply connection CEE 5-PLUG 32A
815	554 21 05	Starter	Starter 356 50/60 Hz Max 600 V Current range: 9 - 14 A supervision
900	694 82 00	Basic repair kit	1

2740.390

Pos. No	Part. No	Denomination	Qty/ Version
			390
1	81 49 05	Hexagon head screw M12X25- A4-70	2
2	82 35 77	Plain washer A4-A170	2
3	680 81 00	Handle	1
4	81 46 75	Hexagon head screw	2
5	82 35 77	Plain washer A4-A170	2
6	94 20 59	Motor cable subcab	SUBCAB 4G2,5+2x1,5 17 - 18mm
6	94 20 60	Motor cable subcab	SUBCAB 4G4+2x1,5 20 - 22mm
6	94 21 06	Motor cable	SUBCAB 10AWG/3-2-1-GC 20,30 - 22,30mm
7	83 02 77	Hex.socket hd screw M6X20-A4-70	2
8	640 89 04	Entrance flange	Cable entry (20)-22mm Cable entry (18)-20mm Cable entry (16)-18mm
8	673 30 00	Entrance flange ISO G1	Cable entry for metal hose (18)-20mm Cable entry for metal hose (16)-18mm Cable entry for metal hose (20)-22mm
8	640 89 02	Entrance flange	Cable entry (22)-26mm
9	678 58 18	Cable clip (16)-18 MM	1
9	678 58 22	Cable clip (20)-22 MM	1

Pos. No	Part. No	Denomination	Qty/ Version	
			390	
9	678 58 20	Cable clip (18)-20 MM	1	
10	82 42 39	Plain washer (16)-18 MM	1	
10	82 42 41	Plain washer (20)-22 MM	2	
10	82 40 62	Plain washer (24)-26 MM	1	
10	82 42 40	Plain washer (18)-20 MM	1	
10	82 42 41	Plain washer (20)-22 MM	1	
11	84 17 93	Seal sleeve (16)-18 MM	1	
11	84 17 95	Seal sleeve (20)-22 MM	1	
11	84 17 96	Seal sleeve (22)-24MM	1	
11	84 17 97	Seal sleeve (24)-26MM	1	
11	84 15 89	Seal sleeve (16)-18 MM	1	
11	84 15 90	Seal sleeve (18)-20 MM	1	
11	84 15 91	Seal sleeve (20)-22 MM	1	
12	81 73 72	Slotted head screw M6X10-A4-70	1	
13	82 23 35	Hexagon nut M12-A4-70	2	
14	82 35 77	Plain washer A4-A170	2	
15	84 94 87	Stud	2	
16	680 26 00	Discharge connection	DN 75 Hose	1
16	680 55 00	Discharge connection	DN 75 Thread : ISO G3A Outer Quick coupling: Storz	1
16	680 55 02	Discharge connection	DN 75 Thread : NPT 3-8 Outer	1
16	680 76 00	Discharge connection	DN 100 Hose	1
16	680 56 00	Discharge connection	DN 100 Thread : ISO G4A Outer Quick coupling: Storz diam=115 mm	1
16	680 56 02	Discharge connection	DN 100 Thread : NPT 4-8 Outer	1
17	82 81 04	O-ring 139.3X5.7 FPM		1
18	679 07 00	Cover		1
19	81 48 79	Hexagon head screw M10X20-A4-70		2
20	82 35 76	Plain washer 10-A4-170		2
21	679 08 00	Connection cover		1
22	82 81 83	O-ring 129.3X5.7 FPM		1
23	630 68 02	Data plate		1
24	82 80 87	O-ring 249.3X5.7 FPM		1
25	81 44 02	Slotted head screw		4
26	710 90 01	Connection term boar		1
27	80 94 49	O-ring 74.61X3.53 FPM		1
28	710 61 00	Bearing cover		1
29	80 94 44	O-ring 117.5X5.34 FPM		1
30	82 81 59	O-ring 119.5X3 FPM		1
31	713 89 00	Stator housing		1
32	80 94 48	O-ring 47.2X3.53 FPM		1
33	83 32 35	Ball bearing		1
34	711 94 05	Stator 19-10-2b	6-leads 50 Hz 230V D 380V-415V Y P2=6,30kW	1
34	711 94 09	Stator 19-10-2b	6-leads 50 Hz 500V-550V D P2=6,30kW	1
34	711 94 14	Stator 19-10-2b	9-leads 60 Hz 440V-460V YSER 220V-230V Y// P2=6,70kW/9hp	1

Pos. No	Part. No	Denomination		Qty/ Version
				390
34	711 94 16	Stator 19-10-2b	6-leads 60 Hz 575V-600V D P2=6,70kW/9hp	1
35	711 95 01	Shaft unit		1
36	82 62 12	Retaining ring SGH 62		1
37	83 30 15	Ball bearing 3305A-2Z/C3VT113		1
38	710 45 01	Inspection screw		1
39	81 78 65	O-ring 12.37X2.62 FPM		1
40	82 71 42	O-ring 183.5X3 FPM		1
41	711 02 00	Bearing holder		1
42	83 03 04	Hex.socket hd screw M8X40-A4-70		6
43	712 56 00	Mechanical seal		1
44	712 68 01	Compression spring		1
45	713 87 00	Plate		1
46	711 35 21	Stud		6
47	710 28 03	Sleeve	MT	6
47	710 28 02	Sleeve	HT 50Hz	6
47	710 28 01	Sleeve	HT 60Hz	6
48	711 37 13	Spacing sleeve	MT	6
48	711 37 14	Spacing sleeve	HT	6
49	82 71 43	O-ring 156X3 FPM		1
50	712 78 03	Oil housing coated	MT	1
50	712 78 04	Oil housing coated	HT	1
51	713 90 00	Mechanical seal		1
52	710 43 01	Adjusting washer		10
53	83 02 97	Hex.socket hd screw M8X16-A4-70		6
54	710 52 00	Protective washer	MT	6
54	710 30 00	Protective plug	HT	6
55	83 48 43	Parallel key 2306-5X5X14-A4-220HB		1
56	713 91 00	Impeller	241 MT 50Hz	1
56	713 91 01	Impeller	242 MT 60Hz	1
56	713 92 00	Impeller	266 HT 50Hz	1
56	713 92 03	Impeller	267 HT 60Hz	1
57	82 34 55	Plain washer		1
58	84 41 93	Hex.socket hd screw		1
59	711 42 02	Diffuser coat.	MT	1
59	712 00 05	Diffuser coat.	HT	1
60	711 37 15	Spacing sleeve	MT	6
60	711 37 14	Spacing sleeve	HT	6
61	82 23 33	Hexagon nut M10-A4-70		12
62	710 28 02	Sleeve		6
63	680 54 01	Strainer		1
64	713 72 00	Strainer bottom		1
65	82 27 28	Lock nut M10-A4-70		6
66	83 20 10	Coupling part	DN 75 Thread : ISO G3A Outer Quick coupling: Storz	1

Pos. No	Part. No	Denomination	Qty/ Version
			390
66	83 20 12	Coupling part DN 100 Thread : ISO G4A Outer Quick coupling: Storz	1
66	83 20 11	Coupling part DN 100 Thread : ISO G4A Outer Quick coupling: Storz diam=115 mm	1
67	83 41 83	Insulating sleeve 0.5-6 MM2	8-11
68	83 41 83	Insulating sleeve 0.5-6 MM2	5
69	83 41 84	Flat pin sleeve 0.75-1.5MM2	2
69	83 41 89	Flat pin sleeve 1-2.5MM2	6-9
70	83 41 89	Flat pin sleeve 1-2.5MM2	2-5
70	84 92 75	Flat pin sleeve 2.5-6MM2	3-5
71	83 43 58	Cable lug INSUL.UL/CSA 1.04-2.6 MM2	1
71	83 42 96	Cable lug 2.5-6 MM2;M6	1-2
72	83 44 24	Closed-end splice 3-6(AWG 12-10) L=18	3
73	83 48 48	Cable tie 98X2.5 MM	1
74	90 17 52	Oil ISO VG 32	*
75	94 05 86	Insulating hose D=12 MM	*
76	340 71 00	Instruction plate	1
77	427 13 00	Marking tape	1
78	667 40 01	Sticker	2
79	766 71 00	Connection plate	1
80	82 21 73	Drive screw 4X5-A4	2
81	718 05 00	Sticker CUT HAZARD	1
82	82 63 86	Retaining ring 25-SPRING STEEL	1
800	694 81 00	O-ring kits	1
801	783 46 00	Zinc anode kit	1
815	554 30 05	Starter Starter 351 50/60 Hz 380V - 415 V Current range: 9 - 14 A supervision Phase sequence indicator Supply connection CEE 5-PLUG 32A	1
815	554 21 05	Starter Starter 356 50/60 Hz Max 600 V Current range: 9 - 14 A supervision	1
900	694 82 00	Basic repair kit	1