



Flygt 8056.280



Table of Contents

Introduction.....	2
Specially approved products.....	2
Product Description.....	3
The data plate.....	3
Product denomination.....	3
Drive Unit.....	5
Standard.....	5
Level sensor.....	6
Leakage detector unit (FLS).....	7
Cable entries.....	8
List of parts.....	11
Hydraulic Unit.....	14
LT/MT/HT.....	14
List of parts.....	15
Installation Components.....	16
Sliding brackets.....	16
Discharge connection units.....	17
List of parts.....	17
Service Parts.....	19
List of parts.....	19

Introduction

Purpose of this manual

The purpose of this manual is to provide necessary information on spare parts and accessories order.

Disclaimer

Always use genuine Flygt parts. The use of other spare parts or accessories can invalidate any claims for warranty or compensation. Xylem does not take any responsibility for damages that are caused by the use of non-original parts. For more information, contact your local sales and service representative.

Data for ordering spare parts

The following information is needed for spare part orders:

- Serial number of the product
- Part number
- Quantity of bulk material, see * in tables

Specially approved products

Qualification of personnel

Only Xylem or Xylem-authorized service personnel may undertake repair work on Ex-approved products.

Dimensional accuracy inspection

Spare parts marked with (Ex) after the part number are subject to dimensional accuracy inspection.

Product Description

The data plate

The data plate is a metal label that is located on the main body of the products. The data plate lists key product specifications. Specially approved products also have an approval plate.

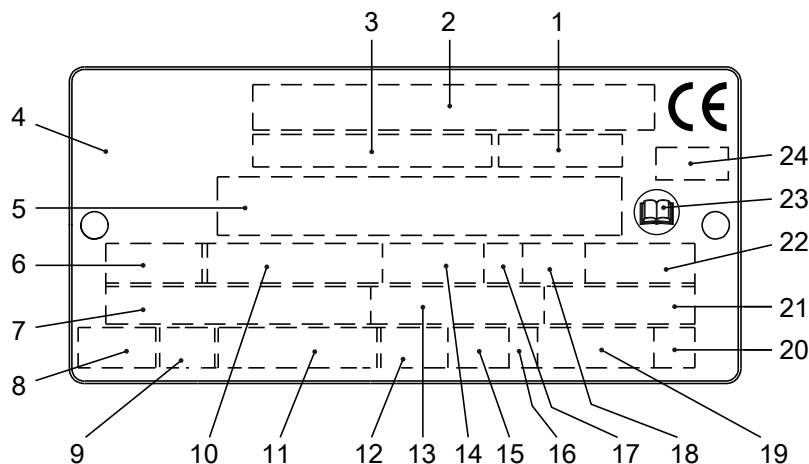

WS006257A

1. Curve code or Propeller code
2. Serial number, see [Product denomination](#) (page 3)
3. Product number
4. Country of origin
5. Additional information
6. Phase; type of current; frequency
7. Rated voltage
8. Thermal protection
9. Thermal class
10. Rated shaft power
11. International standard
12. Degree of protection
13. Rated current
14. Rated speed
15. Maximum submergence
16. Direction of rotation: L=left, R=right
17. Duty class
18. Duty factor
19. Product weight
20. Locked rotor code letter
21. Power factor
22. Maximum ambient temperature
23. Read installation manual
24. Notified body, only for EN-approved Ex products

Figure 1: The data plate

Product denomination

Reading instruction

In this section, code characters are illustrated accordingly:

X = letter

Y = digit

The different types of codes are marked up with a, b and c. Code parameters are marked up with numbers.

Codes and parameters

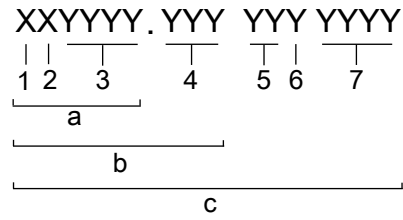

WS006265B

Type of Callout	Number	Indication
Type of code	a	Sales denomination
	b	Product code
	c	Serial number
Parameter	1	Hydraulic end
	2	Type of installation
	3	Sales code
	4	Version
	5	Production year
	6	Production cycle
	7	Running number

Drive Unit

Standard

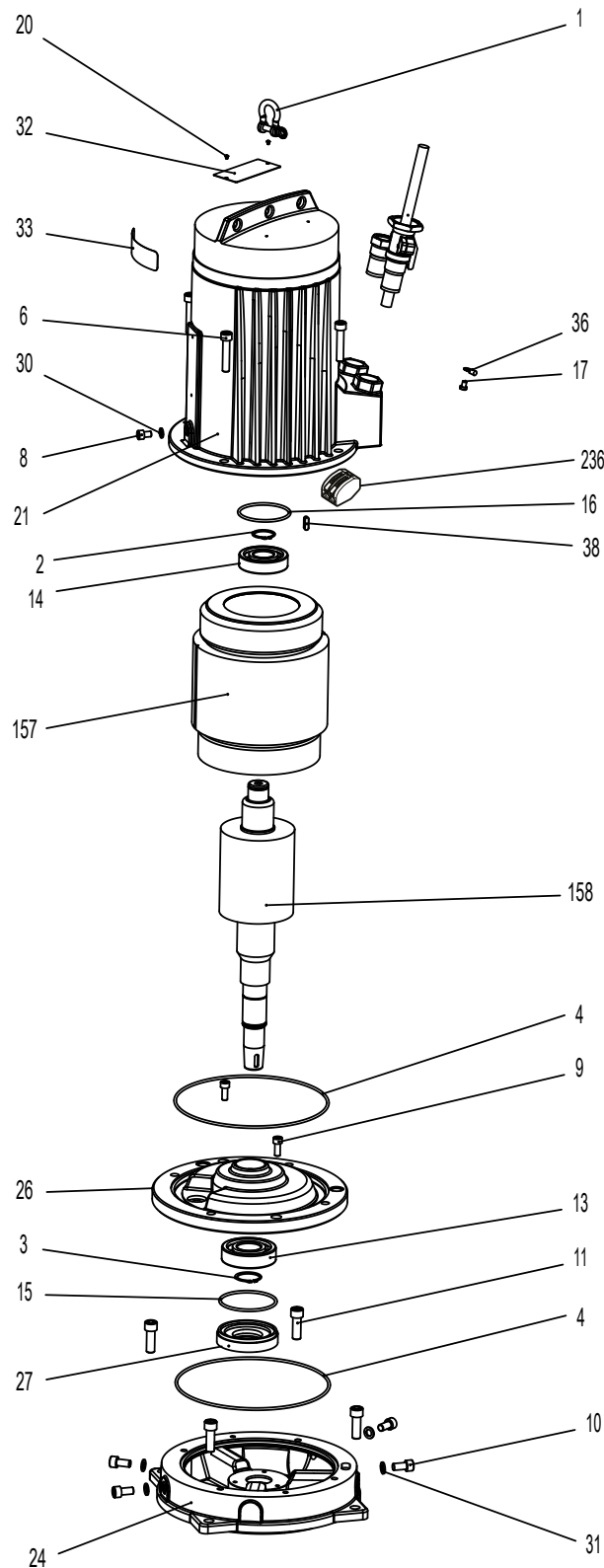

31518C

Level sensor

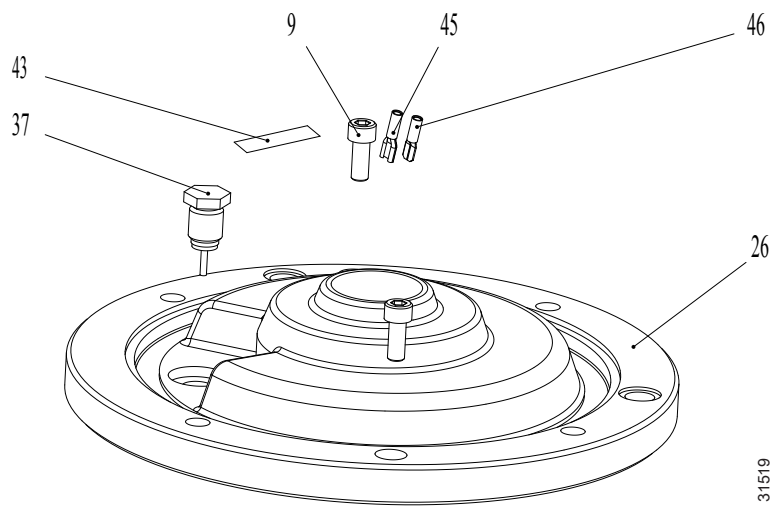

31519

Leakage detector unit (FLS)

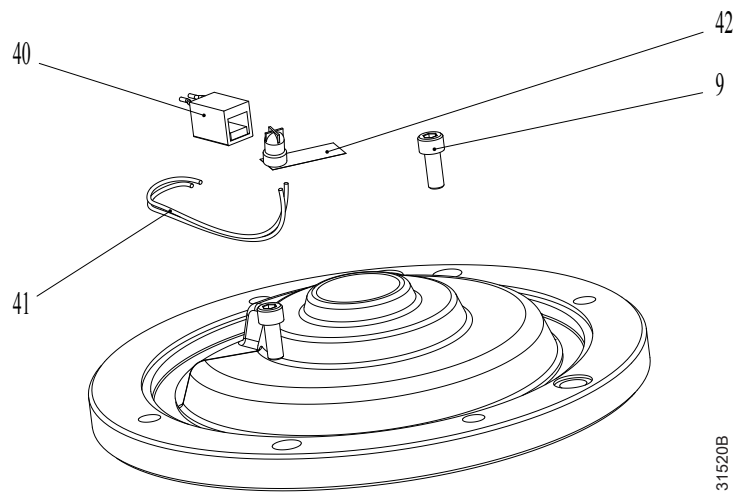

311520B

Cable entries

Single cable, without cable protection

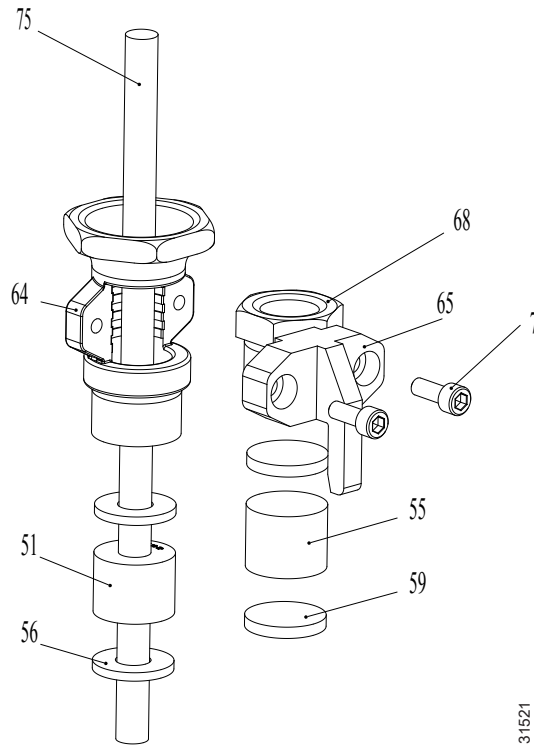

Two cables, without cable protection

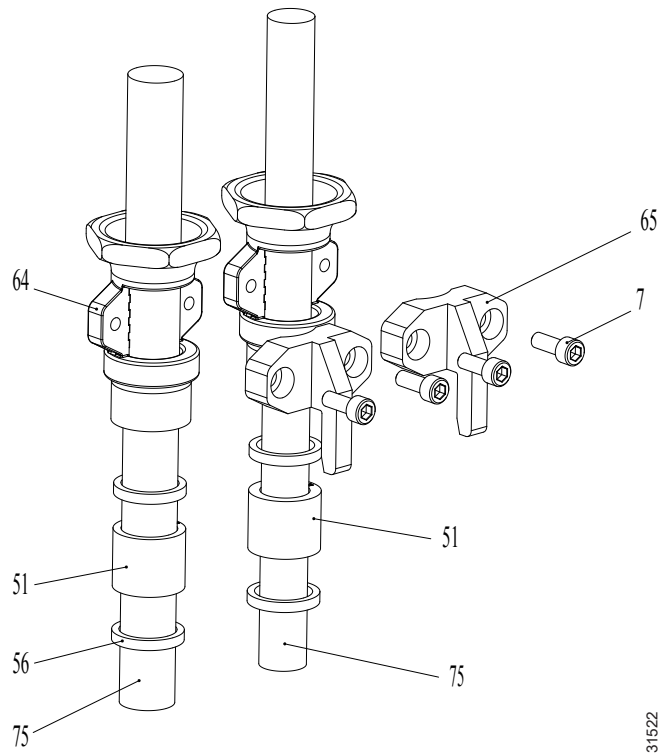

Single cable, with cable protection

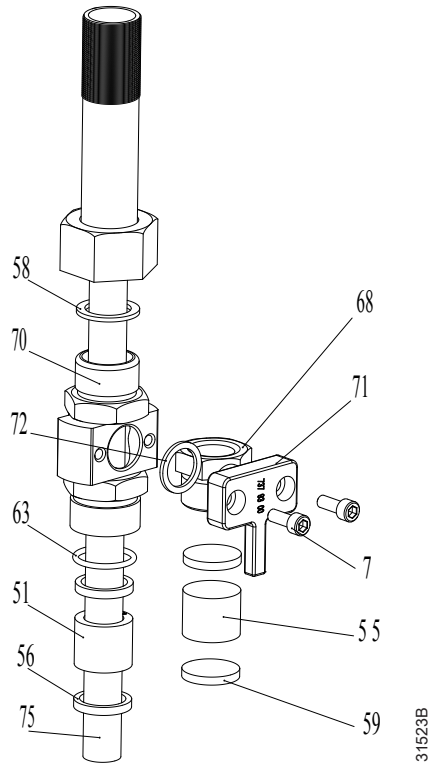

Two cables, with cable protection

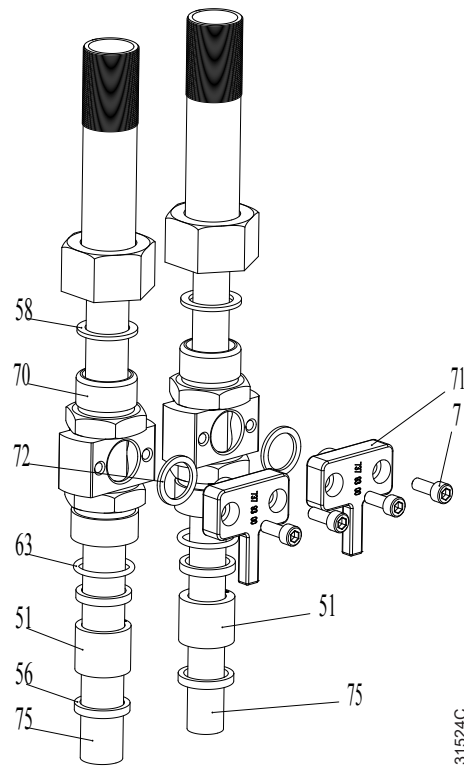

List of parts

Pos. No	Part. No	Type	Denomination	Qty/Version
				280
1	82 38 84		Shackle	1
2	82 60 92		Retaining ring SGA 20	1
3	82 61 33		Retaining ring SGA 35	2
4	82 71 70		O-ring 221.84X3.53 FPM	2
6	83 02 00		Hex.socket hd screw M10X50-A4-80	4
7	83 02 75		Hex.socket hd screw M6X16-A4-70	3
7	83 02 75		Hex.socket hd screw M6X16-A4-70	2
7	83 02 75		Hex.socket hd screw M6X16-A4-70	4
8	83 02 95		Hex.socket hd screw M8X12-A4-70	1
9	83 02 99		Hex.socket hd screw M8X20-A4-70	2
9	83 02 99		Hex.socket hd screw M8X20-A4-70	3
10	83 03 21		Hex.socket hd screw M10X20-A4-70	4
11	83 03 47		Hex.socket hd screw M12X35-A4-70	4
13	83 76 41		Ball bearing	1
14	83 33 13		Ball bearing 20X52X15 MM	1
15	83 76 47		O-ring 78.97X3.53 FPM	1
16	83 76 44		O-ring 52.39X3.53 NBR	1
17	83 76 56		Slotted head screw M6X8	1
20	82 21 73		Drive screw 4X5-A4	6
21	736 97 00		Stator housing	1
24	737 27 00		Oil housing	1
26	737 36 00		Bearing housing	1
26	737 36 02		Bearing housing WITH WATER DETECTOR	1
27	737 37 00		Bearing cover	1
30	583 32 01		Seal ring HNBR	1
31	583 32 03		Seal ring HNBR	4
32	630 68 00		Data plate USE 6306801 AS SPARE PART	2
33	667 40 03		Sticker FLYGT STICKER	2
36	81 79 30		Cable lug 2.5 - 6 MM2	1-2
37	83 76 39		Level sensor unit	1
38	83 76 50		Parallel key	1
40	518 89 02		Leakage detect.unit (FLS)	1
41	504 78 07		Cable unit	1
44	340 71 00		Instruction plate	1
45	83 43 47		Flat pin sleeve	1
46	83 76 61		Flat pin sheet	1
55	83 76 09		Seal sleeve BLIND (FPM)	1
55	83 76 26		Seal sleeve Ø10-12 MM (FPM)	1-2
55	83 76 06		Seal sleeve Ø18-21 MM	1-2
55	83 76 07		Seal sleeve Ø21-23 MM	1
55	83 76 11		Seal sleeve Ø17-20 MM	1-2

Pos. No	Part. No	Type	Denomination	Qty/Version
				280
55	83 76 08		Seal sleeve BLIND	1
56	83 76 27		Plain washer 12X27.5X3-A4	2-4
56	83 76 14		Plain washer 22X27.5X4-A4	2-4
56	83 76 24		Plain washer 17.5X27.5X4-A4	2
58	83 76 16		Seal ring	1-2
59	83 76 23		Plain washer 27.5X4-A4	2
63	83 76 45		O-ring 25.07X2.62 FPM	1-2
64	737 85 00		Motor cable entry LONG	1-2
65	737 88 00		Cable clamp Ø12-14 MM	1-2
65	737 86 00		Cable clamp Ø15-17 MM	1
65	737 87 00		Cable clamp Ø18-23 MM	1-2
65	737 92 00		Cable clamp Ø15-17 MM	1
65	737 90 00		Cable clamp Ø21-23 MM	1
68	737 89 00		Motor cable entry SHORT	1
70	737 91 00		Motor cable entry FOR CABLE PROTECTION	1-2
71	737 93 00		Cable clamp Ø18-21 MM	1-2
72	738 34 00		Seal ring	1-2
75	94 20 44		Motor cable subcab	*
75	94 20 60		Motor cable subcab	Power cable x 1 SUBCAB 4G4+2x1,5 Power cable x 2 SUBCAB 4G4+2x1,5
75	94 20 82		Motor cable subcab	Power cable x 1 SUBCAB 7G2,5+2x1,5 Power cable x 2 SUBCAB 4G2,5+2x1,5
75	94 20 59		Motor cable subcab	Power cable x 2 SUBCAB 4G2,5+2x1,5 SUBCAB 7G2,5+2x1,5 Power cable x 1 SUBCAB 4G2,5+2x1,5
75	94 20 91		Motor cable hcr	Power cable x 1 S07E6E5-F 7G2,5 Power cable x 2 S07E6E5-F 7G2,5
157	737 12 01		Stator 17-10-2r	50 Hz 2-poles 380V-400V D P2=5kW 60 Hz 2-poles 440V-460V D P2=5,70kW/7,70hp
157	737 12 02		Stator 17-10-2r	50 Hz 2-poles 220V D P2=5kW
157	737 12 03		Stator 17-10-2r	50 Hz 2-poles 500V D P2=5kW 60 Hz 2-poles 575V D P2=5,70kW/7,70hp
157	737 12 04		Stator 17-10-2r	60 Hz 2-poles 460V YSER 230V Y// P2=5,70kW/7,70hp
157	737 12 05		Stator 17-10-2r	50 Hz 2-poles 415V D P2=5kW 60 Hz 2-poles 480V D P2=5,70kW/7,70hp
157	737 12 06		Stator 17-10-2r	60 Hz 2-poles 380V D P2=5,70kW/7,70hp
157	737 12 07		Stator 17-10-2r	60 Hz 2-poles 220V D P2=5,70kW/7,70hp

Pos. No	Part. No	Type	Denomination	Qty/Version
				280
157	737 09 01		Stator 17-12-4r 50 Hz 4-poles 690V Y 380V-415V D P2=6kW 50 Hz 4-poles 380V-415V D P2=5kW 60 Hz 4-poles 440V-480V D P2=5,90kW/7,90hp	1
157	737 09 02		Stator 17-12-4r 50 Hz 4-poles 220V D P2=5kW 50 Hz 4-poles 220V D P2=6kW	1
157	737 09 03		Stator 17-12-4r 50 Hz 4-poles 500V D P2=5kW 60 Hz 4-poles 575V D P2=5,90kW/ 7,90hp 50 Hz 4-poles 500V D P2=6kW	1
157	737 08 01		Stator 17-14-4r 50 Hz 4-poles 690V Y 380V-400V D P2=7,50kW 60 Hz 4-poles 440V-460V D P2=8,60kW/11,50hp	1
157	737 08 02		Stator 17-14-4r 50 Hz 4-poles 220V D P2=7,50kW	1
157	737 08 03		Stator 17-14-4r 50 Hz 4-poles 500V D P2=7,50kW 60 Hz 4-poles 575V D P2=8,60kW/ 11,50hp	1
157	737 08 04		Stator 17-14-4r 60 Hz 4-poles 460V YSER 230V Y// P2=8,60kW/11,50hp	1
157	737 08 05		Stator 17-14-4r 60 Hz 4-poles 380V D P2=8,60kW/ 11,50hp	1
157	737 08 06		Stator 17-14-4r 60 Hz 4-poles 220V D P2=8,60kW/ 11,50hp	1
157	737 08 07		Stator 17-14-4r 50 Hz 4-poles 415V D P2=7,50kW 60 Hz 4-poles 480V D P2=8,60kW/ 11,50hp	1
157	737 09 04		Stator 17-12-4r 60 Hz 4-poles 460V YSER 230V Y// P2=5,90kW/7,90hp	1
157	737 09 05		Stator 17-12-4r 60 Hz 4-poles 380V D P2=5,90kW/ 7,90hp	1
157	737 09 06		Stator 17-12-4r 60 Hz 4-poles 220V D P2=5,90kW/ 7,90hp	1
158	737 23 00	(Ex)	Shaft unit	1
158	737 18 00		Shaft unit	1
158	737 16 00	(Ex)	Shaft unit	1
229	82 70 85		Cap 5X10 MM PVC	1
236	83 42 65		Terminal block	2
236	83 42 67		Terminal block	3
236	83 42 65		Terminal block	8
236	83 42 66		Terminal block	3
236	83 56 75		Shrinking terminal	6
236	83 42 65		Terminal block	1

Hydraulic Unit

LT/MT/HT

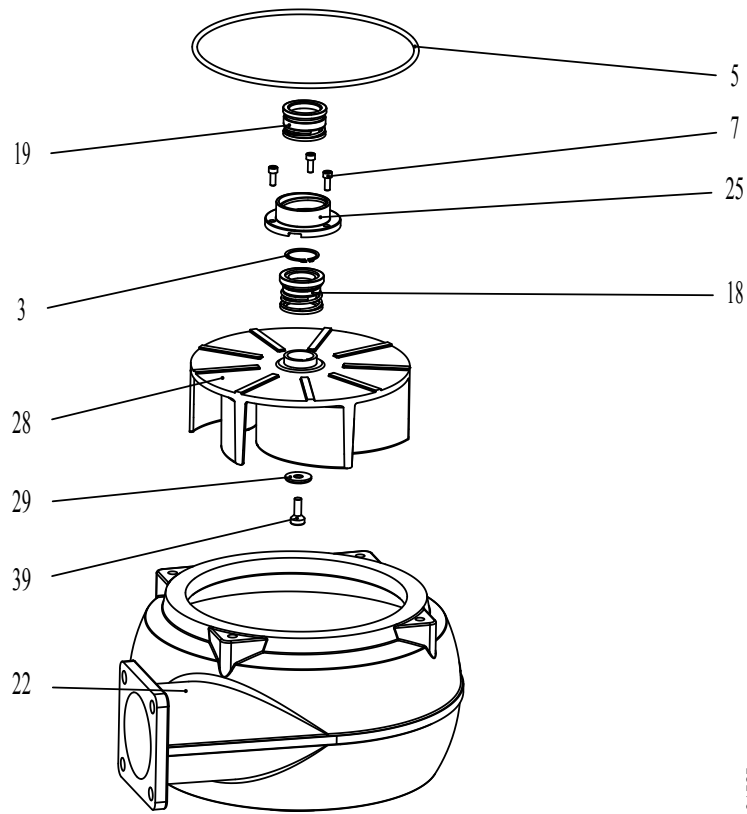

31525

List of parts

Pos. No	Part. No	Denomination	Qty/Version
			280
5	82 80 87	O-ring 249.3X5.7 FPM	1
18	83 76 73	Mechanical seal	1
19	83 76 76	Mechanical seal	1
22	737 00 00	Pump housing	1
		MT/HT	
22	737 02 00	Pump housing	1
		LT	
25	737 34 00	Seal sleeve	1
28	737 38 00	Impeller Ø225	1
28	737 38 02	Impeller Ø210	1
28	737 38 04	Impeller Ø200	1
28	737 38 05	Impeller Ø190	1
28	737 39 03	Impeller Ø235	1
28	737 39 05	Impeller Ø220	1
28	737 39 06	Impeller Ø210	1
28	737 39 07	Impeller Ø200	1
28	737 39 08	Impeller Ø190	1
28	737 39 09	Impeller Ø180	1
28	737 39 10	Impeller Ø170	1
28	737 39 11	Impeller Ø160	1
28	737 40 04	Impeller Ø155	1
28	737 40 05	Impeller Ø150	1
28	737 40 07	Impeller Ø140	1
28	737 40 09	Impeller Ø130	1
28	737 40 11	Impeller Ø120	1
28	737 40 12	Impeller Ø110	1
29	737 47 00	Plain washer	1
39	83 76 72	Hex socket hd screw	1

Installation Components

Sliding brackets

LT

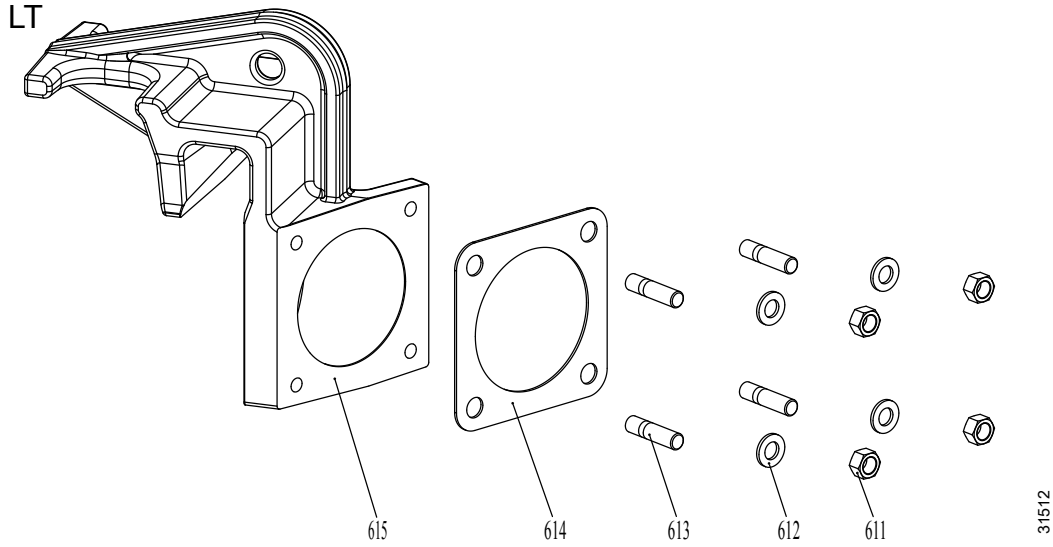

MT/HT

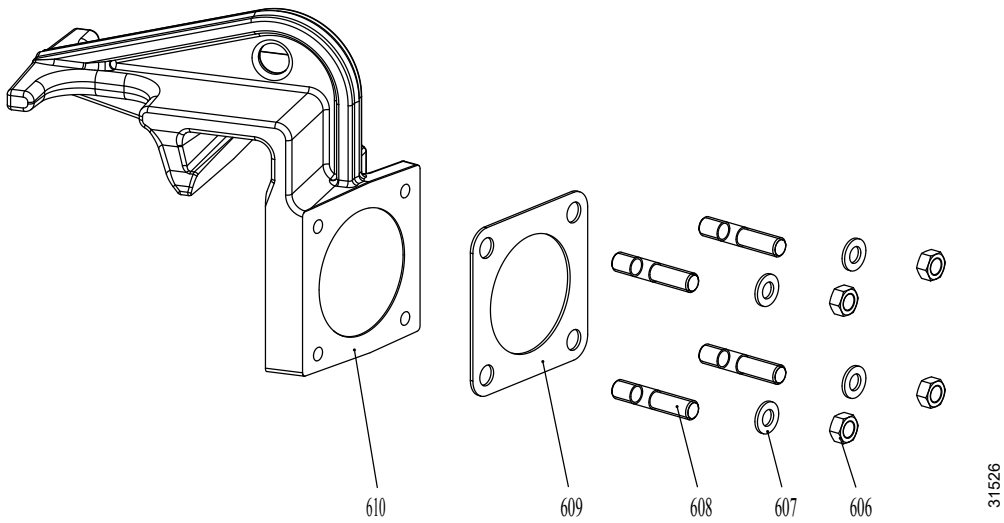

Discharge connection units

LT

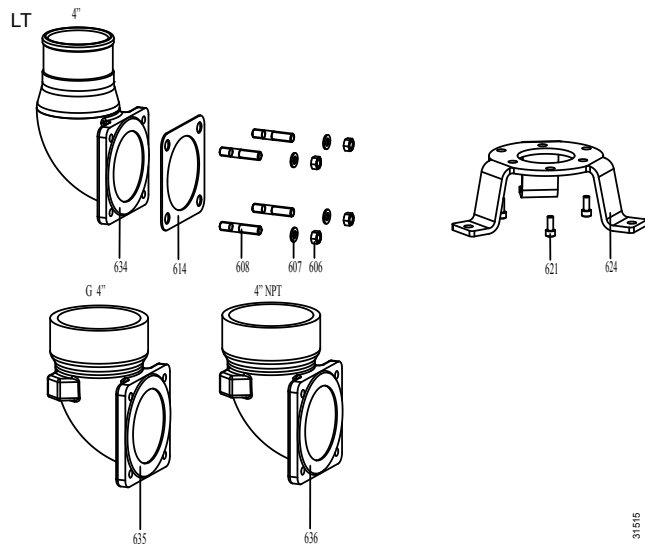

3185

MT/HT

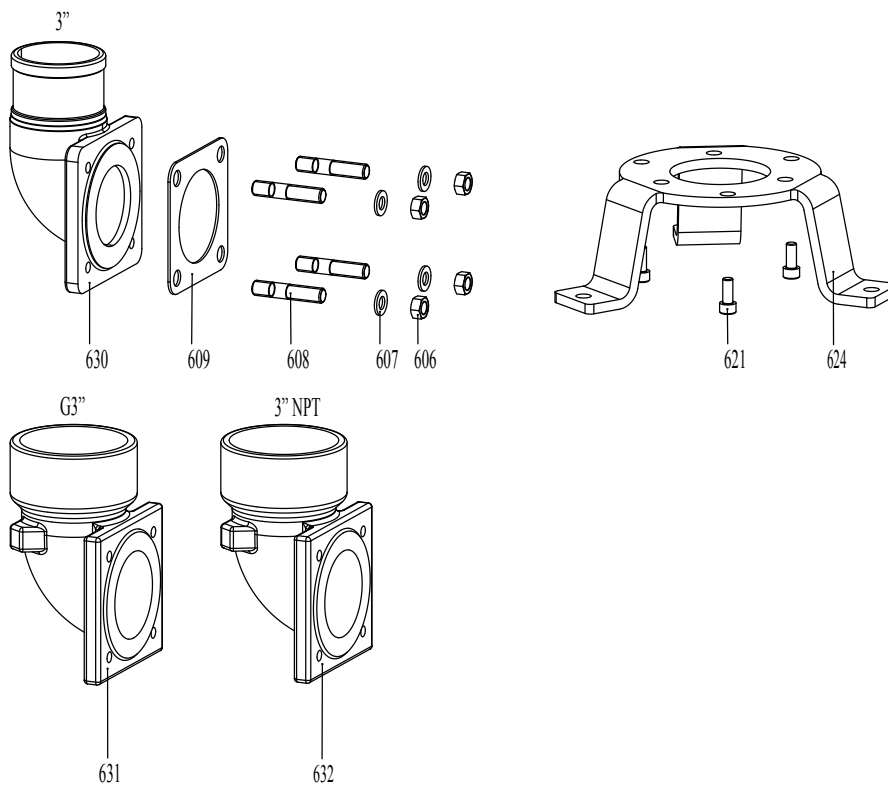

31527

List of parts

Pos. No	Part. No	Denomination	Qty/Version
			280
606	82 23 33	Hexagon nut M10-A4-70	4
606	82 23 35	Hexagon nut M12-A4-70	4

Pos. No	Part. No	Denomination	Qty/Version
			280
607	82 35 76	Plain washer 10-A4-170	4
607	82 35 77	Plain washer A4-A170	4
608	80 97 39	Stud 12X30-A4-70	4
608	83 76 49	Stud 10X30-A4-70 10X30-A4-70	4
609	738 36 00	Gasket	1
610	737 60 00	Sliding bracket	1
611	82 23 35	Hexagon nut M12-A4-70	4
612	82 35 77	Plain washer A4-A170	4
613	80 97 40	Stud 12X35-A4-70	4
614	738 35 00	Gasket	1
615	737 61 00	Sliding bracket	1
621	83 03 23	Hex.socket hd screw M10X25-A4-70	3
623	753 45 00	Stand	1
624	753 46 00	Stand	1
630	737 80 00	Discharge connection	1
631	737 84 00	Discharge connection	1
632	737 84 01	Discharge connection	1
634	737 83 00	Discharge connection	1
635	737 82 01	Discharge connection	1
636	737 82 00	Discharge connection	1

Service Parts

List of parts

Pos. No	Part. No	Denomination	Qty/Version
			280
96	90 17 52	Oil	*
800	83 87 40	O-ring kits	1
900	756 43 00	Basic repair kit	1